

ROVERS

MAGAZINE



Original Land Rover Technical Publications



The most comprehensive compilation of Land Rover factory information available by vehicle model ever released to the public.

Compiled on easy-to-use DVDs for fast and accurate technical referencing. Each DVD includes; parts publications, service publications, owner's handbook and all relative published information by Land Rover for each vehicle.

When applicable the DVDs will also include; audio and navigational handbooks, special service tool manuals, labor times, Testbook user manual, T4 diagnostic system user manual, on-board diagnostic handbook, electrical troubleshooting guide, pre-delivery inspection, sales brochure, accessories brochure and fitting instructions. All combined in one easy-to-use DVD set for your Land Rover.

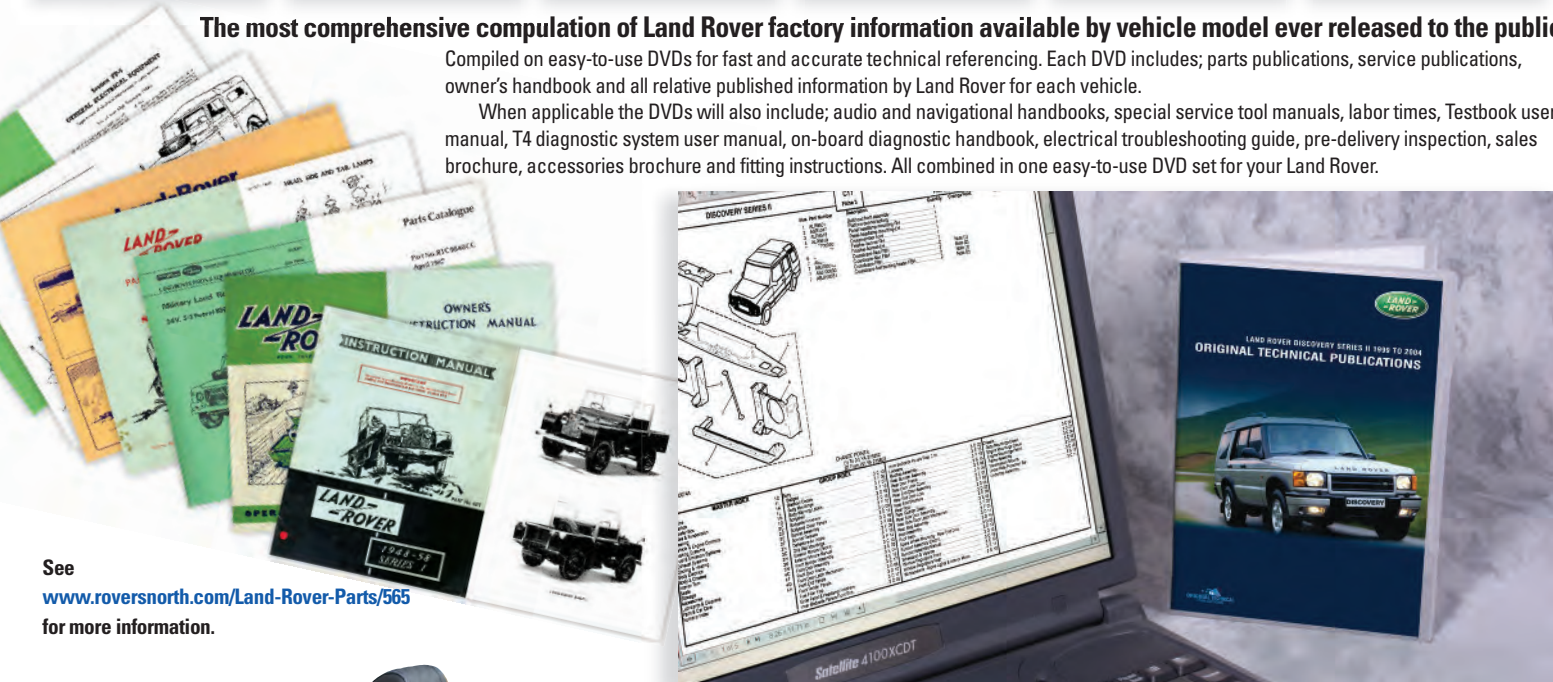

See www.roversnorth.com/Land-Rover-Parts/565 for more information.



NEW DEFENDER ELITE MKII SEATS. SEE PAGE 55.

CUSTOM DESIGN YOUR DREAM INTERIOR

EX Moor
Trim signature



AVAILABLE THROUGH AUTHORISED FITTING CENTRES www.exmoortrimusa.com



About the cover:

Off-Piste 1994, climbing the summit of Mt. Washington on glare ice.

Photo: Phil Berg

Rovers Magazine is a publication of Rovers North, Inc.
Publisher: Mark Letorney
Editor: Jeffrey Aronson
Art Director: Thompson Smith
Photography: Zack Griswold, Kevin Thomas King
Websites/Branding: Graham Letorney
Contributing Editor: Tiffany Pfeiffer
 ©2015 Rovers North, Inc.

This publication is written for the enjoyment of Rovers North customers and may not be reproduced without the express written permission of Rovers North Inc. While we at Rovers North make every effort to ensure accuracy within these pages, we are not to be held liable for typos and or omissions.

Please be advised that all prices are subject to change without notice.

Rovers North Inc.
 1319 VT Route 128, Westford,
 Vermont 05494-9601, USA
 Sales: 1-800-403-7591
 Tech Line: (802) 879-0032
 Website: www.roversnorth.com
 Hours: Mon-Fri: 8:00 - 6:00
 Sat: 8:30 - 12:30 EST
 Sightings submissions may be sent to our above address or email to sightings@roversnorth.com

Whether you're trudging through the snow, fighting off the winter chill, exploring the desert or gallivanting on a beach this winter, your Land Rover will get you there.

In February 1994, a 9-person Rovers North team with two Range Rover Classics and a Land Rover 110 completed the first and only unassisted winter ascent of Mt. Washington, a 6,288 ft. peak with infamously severe weather and 200-mile view on a sunny day. To celebrate we contacted each of the team members to share their memories of this historic expedition.

Is New Hampshire too cold for you? Sean Reagan and Mittie Babette Roger took *La Poderosa*, their '95 NAS Defender 90, 2,600 miles round trip from Mexico to Guatemala. At times their paths crossed the route of the famous 1995 Camel Trophy *Mundo Maya*.

Photojournalist Nicholas Bratton competed in the famous Pacific Northwest Land Rover Club's Northwest Challenge last fall and shares the wonders of central Washington with us. This year's Challenge took competitors through dense evergreen forests, along windswept ridges and over 4,000-foot passes, over broken basalt moonscapes, and through the dusty steppe of central Washington—as he notes, “a paradise for Land Rover enthusiasts.”

We drove an LR2 to this year's Mid Atlantic Rally, the long-running event of the Rovers Owners of Virginia, and basked in humid warmth, froze in snow flurries and enjoyed the spectacular farm and forest trails of western Virginia's Giles County. The autumn foliage colors and mountaintop views just added to the delight of the weekend.

This issue's regular columns will, we hope, give you some entertaining moments in between your Land Rover drives. Bill Burke has once again shared his off-road expertise in many parts of North America. We also wanted to celebrate Fabulously British activities in South Africa and Canada.

You don't have to tackle a mountain like Mt. Washington, with its record-setting 231 mph wind gusts, to enjoy adventures in your Land Rover. Parents will appreciate Kim Conolly's experiences camping with her two kids in Oregon in their Discovery's roof top tent.

These are exciting times for Land Rover, with the introduction of the new Discovery Sport this spring and the addition of the Td6 diesel engine for Range Rover and Range Rover Sport for the Fall 2015. Rovers Magazine will continue our coverage in our next issue.

Many enthusiasts have access to a heated garage—or a knowledgeable mechanic—and find the winter a perfect time to tackle those maintenance and/or upgrade jobs. As always, Rovers North presents many products to help you get the most out of your Land Rover. We thank you for reading *Rovers Magazine* and for letting Rovers North be a part of your Land Rover experience. //

Jeff Aronson
 Editor, *Rovers Magazine*



Our mission is to support all original Land Rover models that are no longer supported

by your local Land Rover franchise. We offer the entire range of Land Rover Genuine Parts direct from Land Rover UK, providing the highest quality parts and accessories at the best prices. In addition we offer our own line of parts called ProLine. Sourced from a variety of manufacturers, ProLine is our alternative when a Genuine Part is no longer available or a lower cost replacement is preferred. Visit our website www.roversnorth.com for a more complete view of our selection, or call us. All new parts and accessories sold by Rovers North are covered by our one year unlimited mileage warranty. We invite you to experience our knowledge, products and friendly service. Thank you for choosing Rovers North.



Land Rover will bring two luxury diesel SUV models to the North America Market. Photo: Land Rover Media Centre

NEW for DEFENDER

LED Clear Light Kits for DEFENDER

- 2x Clear Rear Stop/Tail Lamps
- 2x Clear LED Parking Lamps
- 1x Clear LED Reverse Lamp
- 4x Clear LED Directional Lamps
- Smart Load Device
- LED License Plate Lamp

PLK290 Shown

W/O Rear Fog GuardPLK290 \$ 469.00
 With Rear Fog Guard.....PLK291 \$ 489.00

FABULOUSLY BRITISH



By Jeffrey Aronson
Photography by Rickert Cloete

Baie geluk to Marna and Edward.

Land Rovers serve many roles, but one of their most engaging is as wedding carriages. Dr. Marna Du Plessis married accountant Edward Turner in September 2014, in Lambert's Bay, South Africa, about 2.5 hours from Capetown. Her '78 Series III brought them to the Muisboskerm, a most unique open air restaurant, for their special day. "The petrol cable did break, but it was fixed the day before and she behaved brilliantly on the wedding day," reported Marna. Congratulations to the Turners for their Fabulously British celebration!

Benoit Kirouac, Calgary, AL, has spent the best times of his 22 years with his father, Francois, in their Land Rovers. He wrote, "My most beloved memories are set in the noisiest environment mankind can endure. I can remember every single 4X4 trip I went on with my father and his old 1964 black Land Rover Series II-A. Just the two of us, trying to find our way through the uncharted lands of North America, in a vehicle that seemed to barely hold together. Fighting against the bottomless mud pits, the thick forests, the deceiving rivers and never ending swamps, with only pre-historic tools to save the day.

I can even remember once where we were knee deep in dirt and a big piece of wood used as a lever at the right place got us out of trouble. The name of his Land Rover was "Lucky" and there was a reason for it. Whatever circle of hell we seemed to be lost in, my father's best friend would always keep running and moving forward. It is a living legend known from the coast of Nova Scotia all the way to North Carolina. Never would it be torn apart by a raging stream or be crushed by doing a barrel-roll on a rocky hill. His frame seemed to be built from titanium and his parts cemented together so nothing could bring them apart.



Now, once the trail was over and we were safe back home, you could be certain Lucky would break down on the way to the convenience store, but the mission was accomplished and he deserved his rest. He could be tracked anywhere just by following the oil stains he left behind him after a tremendous victory over nature. Nowadays, my father's health does not allow him to go off on adventures anymore, but he made sure the legend would be kept alive. He passed Lucky to my step-brother so he would remain in the family. One day, I will have my own Land Rover, and hopefully I will be able to create a new legend with my son."

In both English and French, this is Fabulously British. 



Product Features

Articles

- 34-35 Hella Optilux LED Work Lights, Wiper Blades
Defender Body Armor, Mud Flaps
- 36-37 Defender Front Trim, Windscreens, KBX
- 38-41 Chassis and Replacement Parts
- 42-43 Bulkhead, Floorboard, Waxoyl, Bonnet
Blackout Kits, Tire Covers
- 44-46 Wheels, Lug Nuts, Hub Caps
- 47 Side and Folding Steps
- 48-49 Seat Belts
- 50-51 Safety Devices, Front Runner
- 52-61 Exmoor Trim Series Interior,
Defender Interior, Rear Seats,
Headliners, Defender AC Kits,
Molded Mats, Carpet Sets, Floor Mats
- 62-63 Discovery II Front Seats, Seat Covers
- 64-65 Land Rover Accessories, Cubby Boxes
- 66-67 Engine Belts, Tools
- 68-69 Discovery II Trim, Window Regulators
- 70-71 Rock Sliders, Diff Guards, Front and
Rear Bumpers, Extreme Off-Road Gear
- 72-76 Suspension, Shocks, Springs
- 77-80 Towing, Replacement Lights, Lamps

Technical Info & Parts Listings

- 81 Mirrors, Lighters, Speedo Cables
- 82-83 Clutch, Drum Brakes, Master Cylinder
- 84-85 Disc Brakes, Brake Lines
- 87-93 Maintenance Parts
- 96-97 Raised Air Intakes, Recovery Gear,
Lamp Guards, Rear Access Ladders

- 2 Fabulously British
- 28 Letters to the Editor
- 30 Behind The Steering Wheel
Jeffrey Aronson
- 32 Burke's Corner
Bill Burke
- 94-95 Sightings



Mundo Maya '14
Story by: Mittie Babette Roger
Photos: Sean Reagan and
Mittie Babette Roger

4



First & Only
Text: Jeffrey Aronson
Photos: Phil Berg

10



Tent Triumphant
Text & photos:
Kim Conolly

18



MAR-Dirty Dancing
Text & Photos: Jeffrey Aronson

20

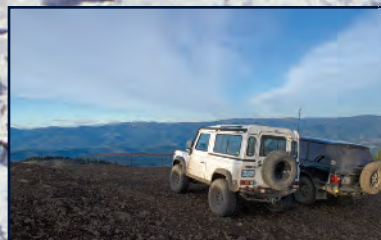

**25 Years of NW
Challenge**
Text and photos by
Nicholas Bratton

24

LAND-ROVER
ROVERS MAGAZINE
ROVERS & NORTH
MEXICO GUATEMALA
MUNDO MAYA '14

Story by: Mittie Babette Roger
Photos: Sean Reagan and
Mittie Babette Roger





[Mittie Babette Roger left her native Louisiana for San Miguel de Allende, Mexico, where she chronicles her creative life through her blog and website. Sean Reagan explores life in Latin America from multiple perspectives, ranging from Washington, DC, to his home in Mexico. -ed.]



Our friends in San Miguel de Allende, our home in south-central Mexico, named our '95 NAS Defender 90, "La Poderosa," or, "The Powerful." The rather stock Land Rover remains beautifully simple, with a no-nonsense approach to getting there. It became the perfect vehicle for our thousands of miles of travel to Guatemala.

It took 870 miles to reach the border at Taisman, Chiapas, Mexico and cross into Guatemala at San Marcos. The no-man's land between the two nations, where we complete our paperwork, feels chaotic. Engulfed first by paperwork facilitators and then by torrential rains, Guatemala issues us a 90-day tourist pass. Exhilarated, we drive for the coast to catch the sunset in playa Tilapita.

Next came a 7,500-foot climb from sea level, winding into the foggy western highlands. Epic views appear around every hairpin turn we take in first and second gear. The crops around us change from plantains to corn and beans.

We pass through Quetzaltenango (the indigenous capital), Lake Atitlan, Antigua (the Guatemalan capital during Spanish colonization), and Chichicastenango—a gorgeous cradle of Mayan culture. We relish





in the mountain villages and farmlands between towns. We give rides to several farmers and their families over the three weeks—the women dressed in colorful huipils, traditional embroidered blouses. Sean especially enjoyed giving a ride to Mr. Camilo Garcia, a Mayan farmer who climbed aboard in the rain, scythe in hand.

Leaving the misty mountains, we took RN15 to Uspantán, where we met Werner. While I explored the hot cocoa and atole (warm rice milk) in the central market area, Werner tells us he has “a couple of these vehicles,” just around the corner. To our surprise, he showed us a '53 Series I and a highly modified '73 Series III, which he uses for competition in off-road meets.

From Werner, we learn of a mechanic in the nearby city of Cobán, who specializes in Land Rovers. The road is not completely paved, so the last slow and careful kilometers drag on as we wind through the mountains on a landslide-prone dirt road. In Cobán, we find the Los Chepes garage, a third-generation Land Rover garage run by Lotario Viduarre and his son. A source of know-how and parts for Central American Rover owners, his garage became the resting place of many a Series—a treasure trove of hard-to-find parts.

From Cobán, we take the road less traveled toward the northern jungles of Petén and the Tikal biosphere. The route had some surprises in store for us. An hour beyond Chisec, Verpaz, we find ourselves





pinned between two barricades of farmers protesting Guatemala's recent laws requiring farmers to certify their corn seeds with the government.

We spend the first day simply observing the peaceful protest. No traffic has been allowed through and a long line of vehicles, including 16-wheelers and local merchants carrying milk and other perishables, waits for permission to pass. Despite this, the situation remains calm until the evening. Noticing the crowd getting rowdier in preparation for a long night of protest, we seek refuge in an area where we camp and make use of a camp stove after a long day without food. We could hear the protesters yelling and chanting through the night.

The next morning, with dwindling resources and no access to a bank or store, we decide to negotiate with the protesters; we'll docu-

ment their battle in exchange for safe passage. We met the leaders at the blockade, made our pitch and received an affirmative vote. The "Five Village Leaders" signed and stamped a document requesting fellow protesters to let us continue north between Raxruha to Sayaxche. At the next roadblock the leaders read the document aloud in Spanish and in Quechi, the local dialect; a representative jumped in the back to escort us through the final roadblock of branches, rocks and burning tires.

We arrive in Tikal exhausted, but the archaeological site restores our energy. Spectacular temples that peek above the jungle canopy serve to remind us that this rainforest metropolis was once one of the most powerful city-states of the Mayan empire. Six large pyramids dominate the site; the most notable of these is the Temple of the Great Jaguar, a 154-foot high funerary dedicated to the city's last ruler.



The 1995 Camel Trophy *Mundo Maya* traveled through here in its efforts to maintain this heritage.

From there, the road home cuts through north-western Belize toward Chetumal, Mexico. We cross the Guatemala-Belizean border around 5pm. It's an easy crossing—no papers, just a stamp in Sean's passport granting us 24 hours to reach Mexico. We drive through the night, smelling the salty air as we near the coast. Climbing back up to 6,300 feet, the clutch fluid begins to leak fairly heavily onto Sean's left shoe—posing a problem when we realize the hood release cable is broken. As the shifting felt tighter, Sean created an alternate hood-popping procedure to top off the clutch and get us home.

La Poderosa covered the 2,641 miles with grace, but having motor oil and clutch fluid was the key to her success. In San Miguel, our bodies still vibrating from the road, we enjoy one of our favorite comfort foods—baked potato topped with cheese and flank steak. There's no place like home. 

[You can read more of Mittie Roger's travels at www.mittieroger.com. Sean Reagan's photography can be viewed at www.seanreaganphotography.com.]



[Mittie Roger loved her trip to Guatemala, but here are excerpts from her "7 Things Not to Do in Guatemala" blog post—ed.]

1. Don't use hustlers at the border to change money or complete paperwork.

It's tempting as a border approaches to want to ask for help, especially in developing nations. However, the folks poised at the border to help you make the transition often have an agenda of their own. Taking advantage of bewildered border-crossers is what they do.

2. Just don't go to Guatemala City.

Guatemala City, the country's capital, is notoriously violent and dangerous. If nothing more, petty theft lies around every corner.

We suggest avoiding it altogether...

3. Avoid the middleman in commerce.

Currently, one of Guatemala's social problems stems from vendors price-gouging the farmers, fisherman and creators of artisanal goods. We recommend going to the source—choosing to buy directly from markets where fishermen, farmers and workers can sell their own goods.

4. Don't fear the police.

Guatemala has a wonderful police department dedicated to tourists, called Politur. They were kind, helpful and went out of their way to direct and assist us, without ever asking for anything in return.

5. Don't assume there is a bank on every corner (or in every town).

Banks are only in larger towns, and while ATMs are readily accessible, they are old... We were pleasantly surprised by how many medium-sized towns had a Banco Azteca (also called Elektra), which changes dollars, euros or pesos.

6. Don't expect good coffee (despite the region being one of the best in the world for it).

Despite being one of the greatest regions in the world for coffee, most of it is exported. Most people drink instant coffee. Gourmet coffee houses are around, but will be advertised as such and (generally) cater to foreigners.

7. Don't drive at night.

Start and end early, especially when overlanding. There is less risk for crime during daylight hours—besides, dangerous road conditions only become more dangerous after dark.



[To see the complete blog post, visit: <https://mittie-roger.squarespace.com>]



“ [Mark] aired down the tires very low,
and showed the deft use of the throttle and clutch,
all through the sensations he got through his hands,
eyes and the seat of his pants. Today's electronics would
not have worked as well as those drivers did.

—Phil Berg

”



FIRST & ONLY

By Jeffrey Aronson
Photography by Phil Berg



Twenty-one years ago on February 1, 1994, a Rovers North team of two Range Rover Classics and a Defender 110 successfully drove up New Hampshire's fabled Mt. Washington. It took seven hours to ascend the narrow 8-mile road in temperatures well below zero, with -70 degree wind chills.

It remains the first and only. No other team has completed a winter ascent without assistance from a Snow Cat. *Car and Driver* chronicled it in May 1994, and the story also appeared in *Land Rover Owner International*, as well as in the then *Rovers North News*.

Unlike promotional events in new vehicles, these Land Rovers had served as daily workhorses at Rovers North's Driving School. The event vehicles consisted of two 1988 3.5L V8 Range Rovers, each having over 100,000 miles and a 1985 3.5L V8 Land Rover 110 Station Wagon.

The team consisted of Rovers North's Mark and Andrea Letorney and then-staff members Lanny Clark, Mike Hopwood, Charlie Haigh and Randy Botala. Rounding out the group were journalists Phil Berg, Jim Allen and Harald Pietschmann. This twenty-first anniversary seemed a good time to interview each of them and share their recollections.

Lanny Clark
*Lanny Clark Restorations,
Colchester, VT*



“Why did we choose Mt Washington? I knew the person who ran the Mt. Washington Hill Climb for sports cars, and through him, got the ok to try the winter climb. The idea had the aspect of extreme sports that I liked and it was only a few hours away.

Mike [Hopwood] and I really researched and planned for this. We knew we had to be ready for anything, from a car fire to accidents. We made several scouting trips to determine weather patterns. One time we drove up in a fog so thick that we couldn’t see the weather observatory at the top, which was directly in front of us. We had to drive with the windows down just to see the road. The weather would determine everything. The winds on Mt. Washington are so strong they could blow a car door of its hinges!

We tried out techniques on Vermont’s Smugglers Notch [*a road closed every winter due to 10-15 ft snow drifts -ed.*], experimenting with sand ladders and ground anchors like the Pull Pal. In the end, we determined the best method would be to ride on top of the snow pack—which would range from 20 feet to bare ground where the winds blew off the snow.

We realized the whole idea would be to go against gravity and the restrictions of the snow. We’d need to get enough power to the wheels to get traction, but not so much that spinning tires would break through the snow. Worse yet, if the Rover did break through in that cold, it would freeze in place. When we did break through we’d have to winch quickly and drive carefully to return to the top of the snow pack.

The entire day was very hard. What I remember most was sweating my ass off! Then, at a lunch break, I took my coat off and got an ice cream headache from the cold. I could have taken a nap.”

Mike Hopwood
The 4x4 Center, Williston, VT



I must have gone over to Mt Washington four times before the actual climb, testing out techniques and conditions. One time I remember sinking up to the axles, breaking a winch line in the cold, dark and wet conditions. On another trip I rode to the top with the Weather Observatory’s Snow Cat checking snow depths along the way. I actually had more difficulty with the pre-running and testing than with the actual event!

Riding on top of the snow crust was a technique we were all aware of, and it became pretty clear that was the only way to get up the mountain. The most dramatic, if not the most difficult, was the final 100 yards. Because of the ice we had to chain up and trust in their traction. If the vehicle started to slide you’d be pitched into oblivion.

While it took 7 hours to get up, it took just over an hour to get down. We followed our tracks back down and the packed snow helped us get decent traction. We needed to pay attention to stay in our tracks.

I’m ready to do this again. Maybe in the coming year or two there might be an opportunity.”





“
*It was my first time being so friggin cold!
 Because my camera gear had to be kept at the same
 temperature as the outdoors, we had to keep the
 windows down in the Range Rover all day.*
 ”
 —Harald Pietschmann



Howie Wemyss
 General Manager, Mt Washington
 Auto Road

“I was here when Rovers North undertook their winter drive up the mountain. No one else had tried it until last winter, when we received a request from the Top Gear crew who wanted to drive up in a Subaru. We told them the car wouldn't make it once it left the groomed part of the road; sure enough, once they hit deep snow they were doomed. They didn't make it all the way up and their trip was completed with “a fair amount of smoke and mirrors,” as they said. Someone had told the Top Gear crew of the Rovers North success. To date no one else has accomplished it.”



Charlie Haigh

Asst. Parts Manager, Berglund Luxury Auto, Roanoke, VA



"I had been on the pre-runs with Mike and Lanny and I rode with Lanny in one Range Rover. I spent a lot of time outside of the car pushing away snow, hauling winch cable and resetting the Pull Pal. The first vehicle would set the ground anchor and the last one would bring it with them for the next run. We spent a lot of time walking back and forth. We were dressed for it, so even though the air temperatures fell to -20 F, it wasn't that bad.

We had no mechanical breakdowns. Once we started off we didn't turn off the Range Rovers all day; they don't burn that much fuel when idling or off-road. And we ran the original style and brand tires—BF Goodrich and Michelins, reduced to 12 psi. They were great all-purpose tires and had a great surface grip."

Phil Berg

Former editor of AutoWeek, senior editor, Car and Driver, now a journalist and author in S. Lyon, MI



"I remember with fondness the trip I took with the crew. That trip came about after I had participated in a winter trek through Canada's Northwest Territories. While in the Canadian Arctic, we drove mostly on snow covered roads in -50 F conditions. But driving through snowdrifts on Mt. Washington was an entirely new experience for me. It felt the same as trying to drive up a ski slope.

You must remember that this came before electronic aids; it was all driver skill. Mark [Letorney] was in a Land Rover 110. He aired down the tires very low, and showed the deft use of the throttle and clutch, all through the sensations he got through his hands, eyes and the seat of his pants. Today's electronics would not have worked as well as those drivers did.

I've been to the engineering centers of GM and Ford. When engineers are in a wind tunnel, they still use their fingers to determine airflow, rather than electronic sensors. I think the same thing held true on two feet of snow with ice underneath. The sensitivity of the fingers surely outstripped anything that electronic sensors might have—the team drivers could do all that with their fingers and feet.

I'm pretty sure today's vehicles would break through the ice and snow! No matter how far vehicles have advanced today, I'm not certain they could match what the Range Rover Classics and Land Rover 110 did. This was way beyond what test drives in new Land Rovers have done for me. It still boggles my mind that we could drive up there with tires, without chains until we got to the last ice-covered 100 feet. At the summit, I slipped and fell down towards a cliff and I could not stop the slide! Once you walked around up there, you realized how dangerous it might be. I don't think we could top that drive today!"

Harald Pietschmann

Trail leader now in La Paz, Baja Mexico, former US correspondent for the German magazine Off Road



"I had met Mike Hopwood at a Rubicon Run; he was the best driver I had ever seen there. When he called me about this adventure, I knew I would be in good hands. I flew in from Los Angeles to find my luggage had not arrived, so I had to borrow and buy winter clothing.

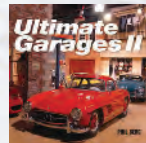

Phil Berg has chronicled the fabulous buildings erected by car collectors in Ultimate Garages book series.



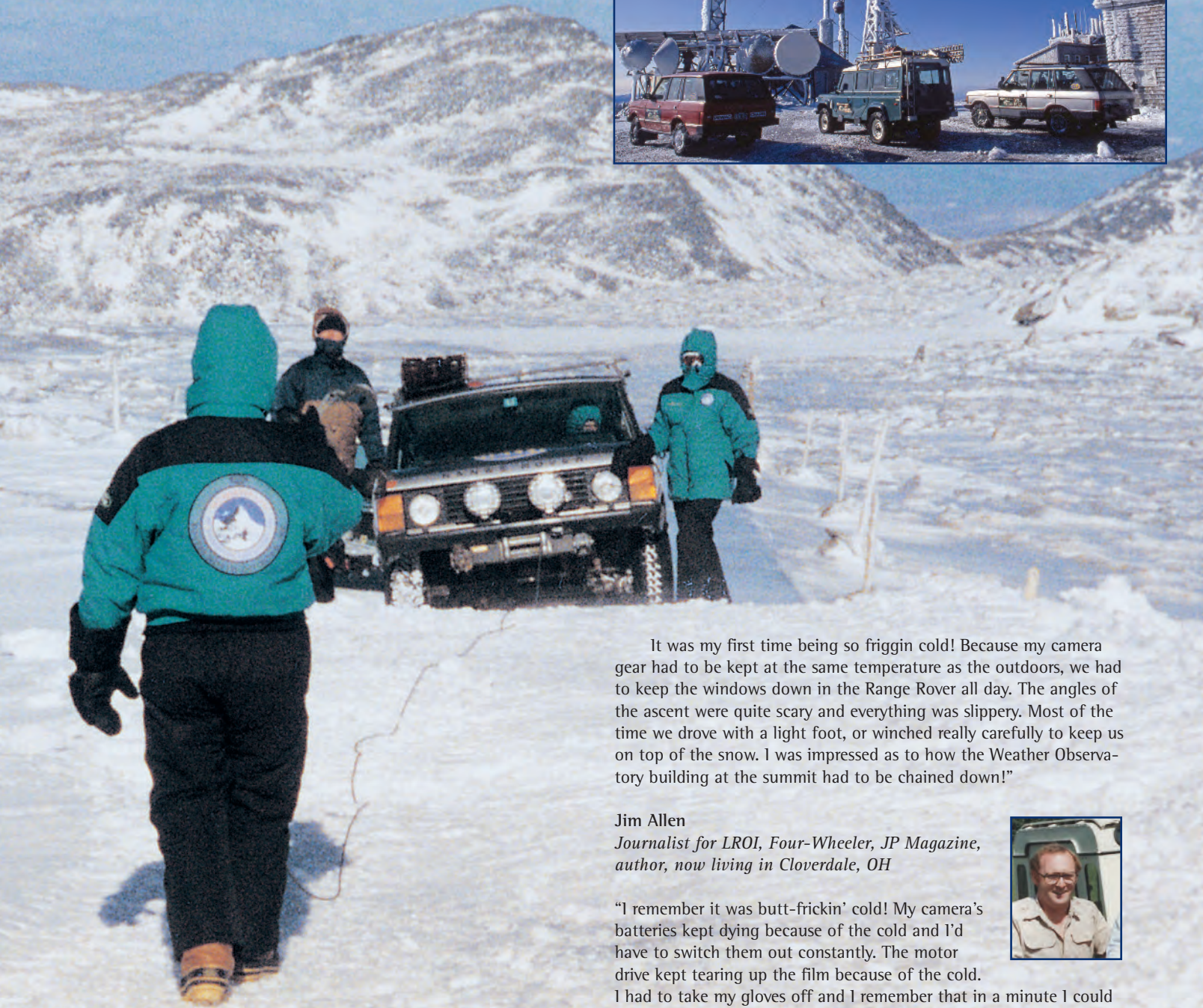

It was my first time being so friggin cold! Because my camera gear had to be kept at the same temperature as the outdoors, we had to keep the windows down in the Range Rover all day. The angles of the ascent were quite scary and everything was slippery. Most of the time we drove with a light foot, or winched really carefully to keep us on top of the snow. I was impressed as to how the Weather Observatory building at the summit had to be chained down!"

Jim Allen
Journalist for LROI, Four-Wheeler, JP Magazine, author, now living in Cloverdale, OH



"I remember it was butt-frickin' cold! My camera's batteries kept dying because of the cold and I'd have to switch them out constantly. The motor drive kept tearing up the film because of the cold. I had to take my gloves off and I remember that in a minute I could feel frostbite coming on!

I'd never driven anything over 8 feet of snow. Frankly, I hadn't thought it was possible. Mark was insistent upon doing it with as stock a vehicle as possible. We made several abortive attempts, but on the actual day we went we had few problems. We couldn't drive through the same tracks as the preceding Rover, but sometimes the trails was too narrow and we had no choice.

The view was so spectacular that I can close my eyes and still see it. There have been times off-roading in the Rockies I've experienced amazing scenes, but because Mt. Washington is the tallest peak in the region, the view was overwhelming!



Andrea Letorney
Co-founder, Rovers North



"I remember it was incredibly well orchestrated, like a choreographed dance. We had very skilled drivers, going about a mile an hour, so it was fun to watch. I was walking with crampons on my boots much faster than they could drive. It was a crystal clear day, but it became really cold, -70 F with the wind chill. We were bundled up—no skin was showing.

I walked up because I loved to hike; I wanted to watch rather than sit and be enclosed. And the driving was quite different than the mud and flat ground at Solihull where I earned my Land Rover Instructor certification. I had wanted to hike down, too, but as it got colder and dark, Mike instructed me to get into the Range Rover; the conditions were getting worse and that made time very important.

We had to trust and work with each other—no arguing, no second guessing. There was genuine danger. The conditions were brutal—even our water bottles were freezing—and we needed to work together to accomplish this. As a company, we had done standard team building; this was team building on steroids." One assumed we would be traveling up a snow covered mountain road. However, the fierce winds had sculpted the snow to the contour of the mountain side, in many places completely eliminating any trace of a road. The snow was so deep it was hard to tell if there was actually a road beneath us or just snow carved flat onto the side of the mountain by the snow cat.

Mark Letorney
Co-founder, Rovers North



Looking back, I remember the possibility of a winter summit was Lanny's idea. Lanny, Randy, Michael, Andrea and myself had recently been trained and certified as driving instructors by the masters at Land Rover UK. Andrea being the first ever Land Rover certified woman instructor. We wanted to create national attention for our driving school. Lanny was convinced that if the weather got really warm, then suddenly dropped below zero it would create a hard layer of frozen snow (piste) that could make it possible to drive on top of the snow without breaking through.

Michael jumped at the challenge and worked tirelessly at preparing our equipment and Range Rovers for the event. From the start we all agreed it was important to keep all the vehicles as stock as possible.

We spent countless hours training mired in deep snow. We practiced on Mt. Mansfield, Vermont's highest peak, where the steep "Smuggler's Notch" road is left unplowed all winter. We developed and perfected some very unintuitive, yet very effective, driving and winching techniques for deep snow.

Michael was big on everything being tested to its limits and pushed our sponsors particularly Warn and Pull-Pal to improve their products. Warn fitted extra heavy clutches and brakes to our winches. We ran 4 modified Warn winches;



View additional photos and original articles of the Mt. Washington Expedition.

www.roversnorth.com/info/16



one on the front of each vehicle and one rear mounted unit on the lead Range Rover. Winching long distances in deep snow proved very challenging. It was such a strain on the Pull-Pals we had to reinforce their shafts with heavy angle iron to prevent their destruction.

Another winching challenge we faced was when the vehicle briefly gain traction it would foul the slack cable in the drum. This would require us to immediately stop winching, or risk crimping the cable as it came back under load. So we developed these buddy lines. We attached a length of nylon rope at a point along the winch cable. This was managed by someone well off to the side but ahead of the vehicle. As soon as the winch cable went slack they would pull it tight again using this line. This allowed vehicle to progress uninterrupted. I remember it taking a lot of effort to dig out the Pull-Pal after the third vehicle used it.

I was the third vehicle, the support 110 with the extra weight. We started our ascent very early at first light to take advantage of the snow texture at dawn. Plus we were concerned about being able to complete the entire climb in one day.

The Mountain Road Company was also very concerned and having second thoughts. Our first planned attempt was scrubbed because of rescue efforts to recover a climber who had perished on the mountain the day before. No one gave us much chance for success so they were not excited about dealing with two disasters in a row. But we were ready.

The Range Rovers' Michelins were aired down to 10-12 psi and both vehicles got up on the piste almost immediately in the early light, but I could not get the 110, with its extra weight, to run atop the crust. Fortunately Harald Pietschmann had a lot of experience in desert expeditions and convinced me to drop the big Michelins down to 8 psi and up on the piste I went.

All was well for the first mile until we rounded the mountain into the full effect of a glowing sunny morning. The sun's effect on the snow's surface was instantaneous. We sank immediately and began the long periods of winch recovery.

We were fortunate to have a young Vermont start up clothing company Denali as a sponsor. They built us excellent inner and outer wear pants, fleeces and jackets that that ventilated and stayed warm in sub zero weather. We could not rely on our vehicles for comfort as their windows were usually down and we were constantly in and out of them. This was really grueling work, fortunately we were all in top physical condition. I kept our drinking water in an insulated cooler to prevent it from freezing.

The only time I had concern for our safety was when I saw the last steep stretch to the summit. I clearly remember seeing myself in the smooth black ice the wind had polished. Pewag was our [Driving School's] chain sponsor and had supplied the Range Rovers with their latest snow and ice chains, but had none for the 110. All I had was a set Randy lent me that he used for snowplowing with his 109. Fortunately my borrowed chains performed flawlessly.

The weather crew was relieved to see us arrive. They gave us a hearty welcome and a tour of their facility they man in two week shifts. The weather station was more like a bunker than a building built into the side of the mountaintop. We arrived on one of the few sunny days they experience during the year. The view from the observation window was clear all the way over the White Mountains of New Hampshire, over the Green Mountains of Vermont, across Lake Champlain and finally ending with a panoramic view of the Adirondack Mountains of New York. It was exhilarating to be there, to have actually made it to the top. ■■



L-R: Randy Botala, Mark Letorney, Charlie Haigh, Andrea Letorney, Lanny Clark and Mike Hopwood.

When camping with little people, we have found adding a roof top tent to our '98 Discovery has made us very loved parents. We reasoned that a tent would save us space, set up time and increase our comfort on the trail. In the Pacific Northwest, protection from predators of the African savannah seemed less likely. After months of planning and several scheduling bumps, I drove to Bend, Oregon and bought my husband, Jason, a rooftop tent for his 40th birthday. We would enter summer adventures in our Land Rover with cushier accommodations.

For our first camping trip over Memorial Day weekend we traveled 1/16th of a mile to the meadow below the house, thus avoiding the Memorial Weekend crowds expected at our regional parks. Jason and Colin spent the weekend tinkering with the tent. Colin brought out his

inner Tarzan, swinging from the Baja rack into the tent through its various doors and windows. Caroline and I enjoyed hot showers and food at the house and the nice campfire outside. That evening we all piled into our new roof top digs. On Monday morning we began to disassemble the tent—that's when the first complications arose.

The Disco no longer fit in the garage with the tent installed on top of the roof rack (and the OME 2" suspension lift to handle the extra weight). With its suspension lift installed, it had just squeaked in on first arrival home. What's happened? Folded down with bedding inside, the tent has suddenly become 2" too high to roll into the garage—and at 172 lbs, the tent also proved too heavy to lift off the Disco! Rover Girl knows her limits, and help or no, she's not lifting that tent. Thus the two engineers, one little and one big, commenced designing and

Tent By Kim Connoly Triumphant



building a rolling frame for the tent to rest on. The new frame and jack bolt arrangement slides out of the garage, encircling the Discovery. The tent is then jacked up off the roof rack, and after the rig pulls out from under it, lowered down to fit through the garage door. Voilà! And drat, my garage parking space has disappeared. Some family members declare the tent has taken its rightful place, but I will miss my “out of the rain” place this winter.

Our next test came over Father’s Day weekend when we headed east over the Cascade Mountains to Clear Lake. Shortly after we set up camp, the neighbors from you-know-where took over the adjacent site. Fortunately, we had dropped our erect/take down time from 40 to 10 minutes. Later that summer we headed for the Metolius River, famous for its fly fishing. We scored a prime riverfront spot and enjoyed a restful weekend watching other people fish while we hiked to the local hatchery and fed the juvenile trout. Trekking home we entered the tiny western-style town of Sisters, Oregon and hit the bakery for one of their famous pine cone donuts. The kids eyed the donuts; the men of Sisters ogled the roof top tent.

Continued on page 86



[Kim and Jason Conolly live in the foothills of the Oregon Coast mountain range with their two children. Faith, family, nature, books, coffee, chocolate, and dirt (in her garden) are some of her favorite things. After stints with a major publisher and the US Forest Service she’s working on book projects for children –ed.]



Kim Conolly’s Packing List for one 5-7 day excursion with kids

On the BAJA Rack:

- 4 Person Roof Top Tent
- 5 Gallon Milspec Gas (reserve fuel)
- 5 Gallon Milspec Water Jug (reserve water)
- Black Rubbermaid Bin for Garbage/Dirty Clothes

Inside the Rig:

- 2 adults and 2 kids
- VHF Ham Radio
- Books on CD
- Navigation/communication computer (with complete electronic copies of the Disco service manuals)
- DeLorme Gazeteer Map Book under the passenger floor mat
- OBDC Diagnostic tool and electrical meter
- Hand Tools, including mechanical and electrical tools and small parts
- Water bottles for each passenger (most with “sippy” type lids for convenience on rough trail)

At the Kids Feet:

- 2 Outdoor Emergency Survival Kits
- Portable HF Ham Radio and wire antennas for evening recreation and emergency communication
- Pulaski
- Shovel
- 2 Leveling blocks
- Fire extinguisher
- Journals and writing supplies

Below the Deck:

- 5 gallon tote filled with gas stove, fuel, small ax, water filter, rope, dishes, etc.
- Coolant and oil
- 5 gallon tote filled with dry goods and food
- Coleman Extreme Cooler filled with 5 days of food (utilizing ice frozen in blocks in quart milk cartons)
- Two 5 gallon water jugs
- 2 REI hiker chairs (for kids)
- 2 adult camp chairs
- 90% Sun shade cloth

On the Deck:

- 4 duffel bags/3 pillows (Colin leaves his pillow home, as he likes to rough it.)
- ALPS fold-up camp table

In the Rear Door Glass:

- Emergency First Aid Kit, stowed for visibility and immediate access

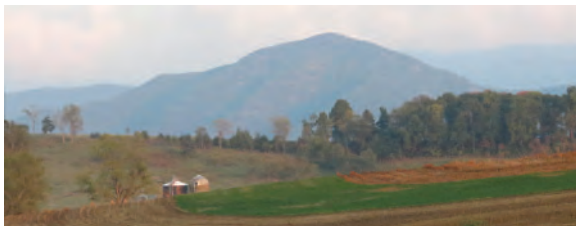

Twenty-eight years ago, the song “The Time of Your Life” closed out the movie *Dirty Dancing*. That song (along with all the hits that ran through the movie) kept running through my head during the October weekend of the Mid-Atlantic Rally, organized annually by the Rovers Owners of Virginia (ROAV). The MAR took place at the Wheatland Farm, just a few miles from The Mountain Lake Lodge, the locale for much of the film. Indeed, the 2014 edition of this iconic event provided me with the time of my life and plenty of moves by Land Rovers on the trails.

Wheatland Farm covers 700 acres on either side of Route 460; 100 acres that served as the campground and MAR headquarters and 600 acres that abut the Jefferson National Forest. Sam Moore’s father bought the property in 1966. Since then he’s continued it as a working farm [General Jeb Stuart’s family once owned the farmhouse], with a portion set aside as the Wheatland EcoPark, a public-private partnership to encourage sustainable business development to Giles County. Sam said, “I’m very pleased that ROAV has brought MAR to the farm. It has such a wide range of opportunities for off-roading. It’s really gone quite well!”

I joined enthusiasts from several states, gawking at the mountain views from the adjacent hillside that served as the event headquarters and campground. John Esser, Clifton, VA, drove his ’97 Defender 90 SW [plaque #53] 6 hours and enjoyed, “The beauty of mountains we saw across the road, which changed every sunrise and sunset with the mist and foliage.” The MAR organizing crew—Bob Steele, David Short, Chuck Yarborough, Mike and Nancy McCaig, Mike and Cyndy Boggs (“and Michael T. Boggs and his chainsaw”)—worked many weekends to carve new trails out of the muddy paths, steep rocky hillsides, fields and forests of Wheatland Farm. David Short noted, “Our greatest challenge for MAR had been to find a longer-term home for the event, and we’re thrilled that the hard work of creating trails will pay off for future MARs.” The hard-fought charting and clearing of trails paid off in a thoroughly-entertaining weekend. MAR offered off-roading from green lanes around the cattle fields, to forest glades, to hilly, rock-strewn paths that sent winches whirring out cable and line.

As I didn’t have the time to drive my Series II-A the requisite 1,000 miles from Maine to Virginia, I flew into Richmond, VA, where Jon Norton of Land Rover Richmond met me at the airport with a loaner LR2. The drive from the coastal plains to the hills by Charlottesville, through the Blue Ridge and Alleghany Mountains, offered spectacular scenes,



MAR

Dirty Dancing



even from an interstate. Plugging the address of my chain motel into the LR2's navigation system, it brought me flawlessly to the entrance, 235 miles from Richmond. It worked much better than the system utilized by United Airlines, which lost my bag filled with the warm clothing required by the 40 degree mornings. United claimed it "could not locate" the motel—actually telling the motel clerk, "There's no such address." (She urged United to give it the old Virginia Tech Hokies try and they found it 24 hours later.)

As I approached Wheatland Farms, the navigation system warned me that it could offer no assistance, but the "MAR" signs on Rte. 460 caught my eye. You entered a dirt path that headed up a steep hill, with several terraced areas offering campsites, each with a spectacular view. A large tent served as the event headquarters, the dining area for Saturday night's dinner and most entertaining auction; should MC David Short decide to leave his career as an emergency systems adviser and firefighter, television should come calling him as a game show host.

While the LR2 clambered up the slippery grassy hillsides with aplomb, I had promised Land Rover Richmond not to take it out on the trails. (I did, however, run up and down the hills gleefully!) So I hitched a ride with ROAV president Bob Steele in his '95 Range Rover Classic, complete with lockers and purpose-mounted laptop with trail maps. Friday's weather had turned cold and rainy, so the forest trails that ran between the cattle fields were exceptionally slippery; it took his lockers to move us back off a steeply crowned trail.

The first morning I arrived in the LR2 to find that an RV had slid on the slippery, hilly path when trying to leave the campsite. Randy McMullan, Robensonia, PA, had driven it down,

while his son Lyle followed in his bare-bones Series II-A. As the RV blocked the one access path, several Land Rovers had sprung into action to first pull the RV gently out of the woods, and then forward out of the field and onto the main road. The range of trailers, "Tent Mahals," and pop-ups that housed the 100 attendees ran the gamut from bespoke to elementary. I shamelessly cadged breakfasts each morning, just by performing my best "starving writer" routine.

The weekend included a trek up some 4,000 feet of fire road tracks that took the convoy past a fall foliage palette of stunning colors and eventually, to an abandoned forest fire watch tower with a spectacular view of 30-40 miles of the Virginia-West Virginia border. By the time we reached the summit, we ran into snow flurries. A second trek of a few hours, this time in Mike and Cyndy Boggs' '93 NAS Defender 110, took me up narrow forest trails that eventually led across the state line into West Virginia. To pop out of the woods, seeing only old growth trees, and suddenly come across rural homes, to a paved road, and find yourself about 35 miles from the MAR campsite, was rather impressive.

The weather alternated between drizzle and sunshine; that assured some nice water crossing and mud holes that kept the winch kits open and active. It also meant that once you ascended up the mountainsides, you got to descend down rock-strewn trails carved through the forests. I jumped in and

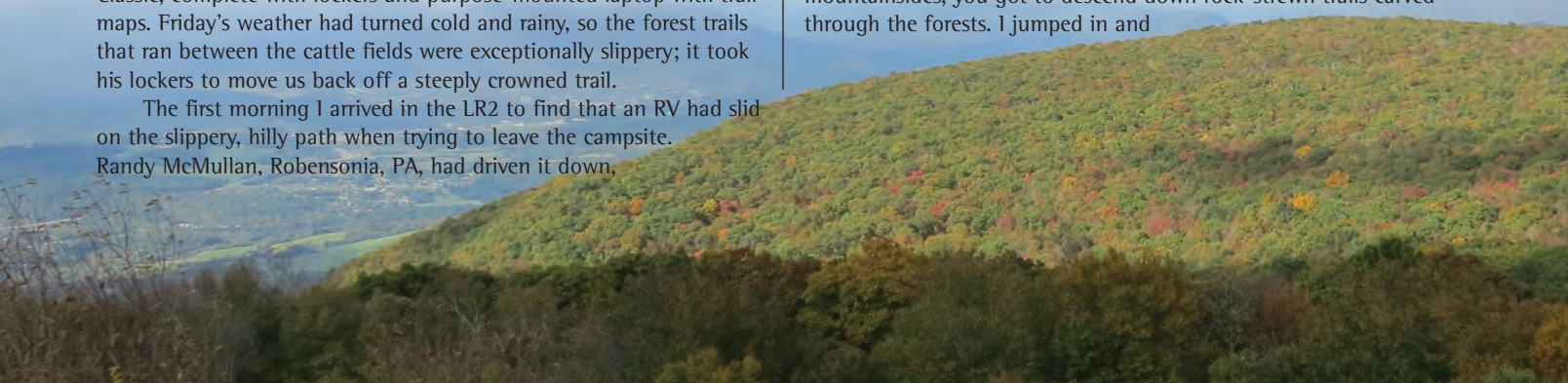

out of a wide variety of Land Rovers. Their range ran from Series II-A's to Defenders, Discoverys to Range Rovers; it was equaled only by the generational range of participants. The little kids running around the fields had as much fun as the older kids driving their Land Rovers throughout the mountains.

Mike McCaig offered his Penlan Farm in Crozier, VA, for the first MARs from 1994-98. When the event attendance exploded to 400, it moved to larger venues in eastern Virginia. After 20 years, it's a smaller event, but the Wheatland Farm site promises a healthy future for this veteran rally. Bob Steele remembered, "I saw my first Defender in person at the '96 MAR. We're seeking to grow this event so that we can appeal to enthusiasts of all the Land Rover models."

Fueling up the LR2 for its trip back to Richmond, I stepped inside the local convenience store to pay. The clerk looked at my Rovers North shirt and said, "Are you with the Land Rover group? We saw them everywhere. Y'all come back now." Maybe Virginia's marketing slogan needs to change to "Virginia is for Rovers." Set aside the first weekend in October for this spectacular locale. Trust me, you'll have the time of your life. //

For more information on Wheatland EcoPark, see <http://www.wheatlandecopark.com>.

For travel information on Giles County, see <http://www.gilescountry.org>.



Land Rover Richmond

By Jeffrey Aranson



Matt Bigelow, the General Manager of Land Rover Richmond, proudly proclaimed he's a "Buffalo native and a huge Bills and Sabres fan." Still, with 6 feet of snow falling last November, he might be happy that he made the move to Virginia.

After graduating from Canisius College with a degree in political science, Matt spent a decade as a fundraiser for nonprofits. In 2002, he bought a '98 Discovery and later gave it to his daughter as her college vehicle. By February 2003, he changed careers and began working at Land Rover Richmond. And yes, the Discovery is still in the family.

Matt evinces a genuine enthusiasm for the marque. "I have a real love of Land Rovers," he said, "which is why I decided to change paths and start working here. I really love the history, the heritage and tradition of Land Rover. It was fun to start here and is still fun to work here." He's enjoyed his contacts with the Rover Owners of Virginia and the dealership supports the club and the Mid-Atlantic Rally.



It doesn't take long in conversation with Matt to understand why he says, "I really have a great crew." I couldn't meet everyone, but Parts Manager Herb Bailey, Sales Guide Johnny Cates and Detail Manager Jon Norton demonstrated they really know and like their Land Rovers. As Matt noted, "Land Rover is quite unique. It's a 'story' brand that transcends all socio-economic boundaries."



Land Rover Richmond recently underwent renovations that moved it away from the '90s L.L. Bean/Orvis hunting lodge look to a more contemporary design. In becoming more urban and sleek it has not forgotten its roots—an "adventure center" wall still features off-roading DVDs, and a "heritage wall" visually outlines the family history all enthusiasts love to see and know by heart. Another wall houses a full range of outdoor Green Oval clothing, and outside the modest-sized sales building, the first-ever Land Rover Centre off-road course still stands ready to thrill new Land Rover customers and entertain veteran owners.

A plaque on the wall from Land Rover North America celebrates the awarding of the franchise in October 1988; that's just a year after the first national dealer event. Twenty-seven years later, it's evidently still enjoyable to be a big part of the Land Rover community in Virginia.

Text and photography by Nicholas Bratton

Panting from the scramble up a steep hill, I pause to catch my breath and take stock. Winch rope in one hand, tree strap in the other, three pounds of cloying mud glommed to each shoe, and a couple of stuck Rovers below—the Northwest Challenge had lived up to its name. As teammate Lar Malleis crested the hill, his smile mirrored my own. This was what we had come for.

A gathering of Land Rover enthusiasts from British Columbia to Oregon, the 25th year of the Northwest Challenge combined off-road driving, navigation, problem solving, mechanical knowledge and special tasks. As usual, this edition featured varied terrain, demanding tasks, and sunny skies over the three days of competition. Given the organizational complexities, hosting alternates between the Pacific Coast Rover Club and Rover Landers of British Columbia; the venue changes among BC, WA and OR. The PCRC's Mike Bach ran this year's event. Assisted by a team of dedicated volunteers, he ensured that the Challenge was demanding, creative and required a broad range of skills to succeed.

The entrants shared the organizers' enthusiasm. Hailing from Portland, Vancouver, and places between, the twelve teams drove Landies of many flavors: two Defender 110s, three Defender 90s, two Discoverys, four Range Rover Classics and a Series II-A hybrid. They ranged from stock to heavily modified for off-road; the Challenge would put them all to the test.

Washington is blessed with spectacular terrain accessible by public trails. This year's Challenge took competitors through dense evergreen forests, along windswept ridges, over 4,000-foot passes, around the base of Mt. Rainier, over broken basalt moonscapes, and through the dusty steppe of central Washington—a paradise for Land Rover enthusiasts.

[Nicholas Bratton, Seattle, WA, developed a passion for Land Rovers at age 6, crossing the Kalahari with his family in a Series II-A 109". His travels include 5 years in Africa, a year in Europe and expeditions to Greenland. He pursues writing and photography with his wife Jenna, their dog Bastien and a '95 Discovery LSE -ed.]

25 Years of NW Challenge

Competition commenced en route to base camp on Friday. Teams had to navigate to coordinates where they would find information about the history and geography of the area. This provided clues to solve problems, whose answers revealed the locations of hidden caches that teams needed to find over the weekend. As the sun sank into the trees the teams gathered for a briefing from Mike, who welcomed everyone, explaining the competition and evening's activity.

Teams paired into groups of two vehicles and set off with a list of coordinates. Near each waypoint a painted marker was hidden, assigned a point value based on how well it was concealed and how difficult it was to reach by Rover. The central task of the Challenge was to score points by finding concealed markers. Lar and I partnered with Gord'n Perrot (one of the original organizers and owner of Seattle's Lamorna Garage) and his navigator, Cary Wright. Over the next few hours we drove the length of the historic Naches Pass trail in darkness, pausing frequently to scamper into the undergrowth in search of markers and occasionally encountering other teams. We also found the hidden cache at the pass containing more clues for the next day's tasks.





Gord'n Perrot negotiating the trials course.



Background: Magnificent view from the top.



L-R: Gord'n Perrot clearing the trail, slightly modified Land Rover for Challenge Events.



A misty morning greeted everyone on Saturday. Upon receiving several more pages of coordinates, the competitors learned of four mandatory tasks we would have to find and complete during the day. Fortunately, the first two of these were near camp. In one, teams had five minutes to sort through a pile of parts and identify which model Land Rover they belonged to. The second was orienteering, which required determining the azimuth of a known point using a magnetic compass and estimating the distance to it.

Having reviewed the coordinates, we realized they were grouped in clusters many miles apart. There was no way we could find them all in the 12 hours allotted, so we prioritized quality over quantity and went for the highest value waypoints. This meant negotiating the most difficult terrain. Off we set and soon found ourselves bouncing up Kaner Hill, winching up Aardvark Hill, and crossing rickety log bridges near Lilly Pond in our quest for points.

By midday we reached the next group of tasks. First was a trials course in which the driver had to pluck tennis balls from stands and

match the unknown time of the driver who set the course. Second was a medical scenario in which teams had to treat a member with a simulated broken leg. The afternoon took us further afield through stunning landscapes in search of a mandatory checkpoint. We faced a conundrum: should we go for the checkpoint, or seek out high-value markers? We went for both and raced against time to return to camp as the sun set.

A cast-iron pot of hearty chili steaming on a fire awaited the teams as they rolled into camp plastered with mud, exhausted and smiling broadly. It felt great to sit still, not bouncing or running, and share tales of the day's adventures around the fire with fellow Rover enthusiasts. Some vehicles had not made it through the day unscathed, but with enterprising spirit teams made field repairs.

Sunday morning brought the final task. In a nearby rock quarry the volunteers had marked out a trials course. The catch? Drivers had to negotiate it in pairs of trucks connected by rope or tow strap. Points would be deducted for stopping, reversing, striking cones, or if the

Right: Drivers negotiating in pairs around the trials course.



Background: Sunday morning trials course with a catch!

connecting line touched the ground. Some teams took creative license in configuring their connecting line, but only one team drove the course cleanly. After a group photo, everyone returned to camp for lunch and closing ceremonies.

Teams received awards based on winning individual tasks and overall scores. Thanks to their intensity, skill, and persistence, Gord'n and Cary earned first place in their "ORange Rover". The array of prizes was impressive. Sponsors and donors had furnished a valuable array of accessories and tools for the winners. Special thanks are due to Rovers North for their generosity, as every team went home with something useful. Recognition is also due to Mike Bach and his fellow volunteers from Pacific Coast Rover Club, who put together a superb competition to celebrate the 25th anniversary of the Northwest Challenge. I'm already looking forward to next year. 🍷

[For more information on Nicholas Bratton's work, visit www.nicholasbratton.com.]



Above: One of the more challenging hillclimbs.

Letters to the Editor

Dear Rovers North,

I have been a Rovers North customer since 1985, when I bought my first Land Rover, a 1965 109" Dormobile (aka "Reggiebwanna"). Reggie is/was the beautiful siren that infected me with "greenovalitis"; apparently I contracted the incurable form of the disease. I still drive, camp in and just stare at it regularly.

I bought a 1988 Range Rover in 1990, (it wasn't called a Classic at that time). I drove it for 12 years before letting it go to a friend,



who still has it. No, I did not encounter a single "Prince of Darkness" issue my whole time with the car. My son drove it to high school for the last four years we owned the car. Sometime during that phase, I noticed that the lettering across the back no longer read "RANGE ROVER", but instead "HANG OVER". While I appreciated his genius with the lettering, I was more appreciative that the local police kept a closer eye on my truck after that.

Around 1992, I found a desolate 88" II-A ragtop tied by a rope to the telephone pole behind my office. Murphy (the only name he would answer to), stayed with our family until my son left for college. Realizing that my son and I would never team up on a concours rebuild, Murphy helped to pay for a bit of college expenses.

In '97, I bought a two-year-old Coniston Green Defender 90 SW. I drove it for nine years, and then had one of the worst lapses in judgment in my entire life—I sold



it. I guess I always wanted to say that I sold something for more than I paid for it, and suppose that was prominent in my feeble mind at the time. The fact that I can now say I made money on a vehicle DOES NOT make me feel any better, but buying a 110 as a replacement did.

Thanks for all the advice, fellowship and Genuine Parts.

Richard Poole, DMD
Madison, MS

[Land Rovers are just what the doctor ordered. Thanks for sharing your experiences with our readers -ed.]

Dear Rovers North, I've been a customer of Rovers North for 10 years now and you guys have supported my Rover habit all the while. The first photo was taken in 2005, when I first purchased the 1963 Series II-A. My kids were ages 3 and 4. The second photo was taken a week ago. As you can see my kids have grown up with that little truck! It's a little bittersweet, but I just sold the II-A and have replaced it with a 110 named "Tithonus". The new truck arrived about two weeks ago from the UK. Of course, I am still purchasing the majority of my parts from my trusted friends at Rovers North. Thanks to all your helpful staff; you folks do a wonderful job!



Jonathan Sayer
Austin, TX

[How fortunate for your family to grow up with Land Rovers! Thanks for sharing the photos -ed.]

Dear Rovers North, We would like to thank all of you at Rovers North for your past sponsorship and generous support of the Arkansas Rover So-



ciety. We appreciate you helping make our rallies a success! We really enjoyed having Les Parker at last year's rally.

We're looking to confirm October 2015 for the next Arkansas Rover Rally at Hot Springs ORV Park. We invite you to once again be a part of our exciting Land Rover venue through rally sponsorship. Have a wonderful week.

Nigel Et Kimberly Jebb
Arkansas Rover Society
Jacksonville, AR

[We wish you every success with the 2015 edition of this great event! -ed.]

Dear Rovers North,

I have been a proud Rovers North customer for over a decade. Your customer care, dedicated and prompt service, Genuine and ProLine Land Rover parts availability and outstanding Rovers Magazine make Rovers North the #1 choice for me and all Classic Land Rover and Range Rover owners. I currently own a beautiful 2004 Land Rover Discovery SE, with a mere 9,000 original miles, and a wonderful 2012 Land Rover LR2. The Land Rover LR2 amazes me with its versatility, reliability and overall quality.

I have been collecting your fine publications since your newsletter was called Rovers North News. The latest and greatest Rovers Magazine is one of the few publications I receive that I truly look forward to reading from cover to cover! I enjoy your enthusiast profiles, such as the article on High Meadow Farm, and your vehicle road tests, like the article comparing the 2013 and 2014 Land Rover LR4. It's also nice to have a selection of your parts and accessories included in each issue of the magazine. Keep up the great work on this treasure for all Land Rover/Range Rover enthusiasts! Thanks to the Rovers North Team for everything you do to keep our Land Rovers and Range Rovers running smoothly.

CPT Sean J. Donohue
Lake George, NY

[Thanks for letting Rovers North be a part of your Land Rover Experience and for your compliments on Rovers Magazine -ed.]

Dear Rovers North,

I just wanted to say hello and thank you for the efforts of your editorial work and beyond with Rovers Magazine. I have been a fan of these cars since seeing the movie Born Free and seeing Marlin Perkins ride around in them on Mutual of Omaha's Wild Kingdom. Okay—going back here a ways. I did obtain a 1963 109" II-A in New Hampshire a few years back and have been enjoying the car. It's in pretty good shape mechanically and looks decent as well. It has a safari top on, but I think it would be more fun with canvas.

Richard Ford
Wakefield, NH

[Thanks for the compliments on the magazine and for letting Rovers North help you enjoy your 109" -ed.]

Dear Rovers North,

Yes, that be The Stonehenge in the background and an '84 Land Rover 90 in the foreground. The guards wouldn't let me drive it any closer, something about an American movie with Chevy Chase in it or something. Nice chaps, otherwise.



Eric Wolff
Newport News, VA

[The movie might be the new Vacation -ed.]



Dear Rovers North,

Considering almost every part on this rover came from you guys I thought I would share these photos. A buddy was married here on Nantucket and asked me to drive him and his bride out on the beach to the steps of the reception. It was amazing!

Mason Kennelly
Nantucket, MA

[Yet another romance-turned-marriage thanks to a Land Rover. Congratulations to the lucky couple! -ed.]

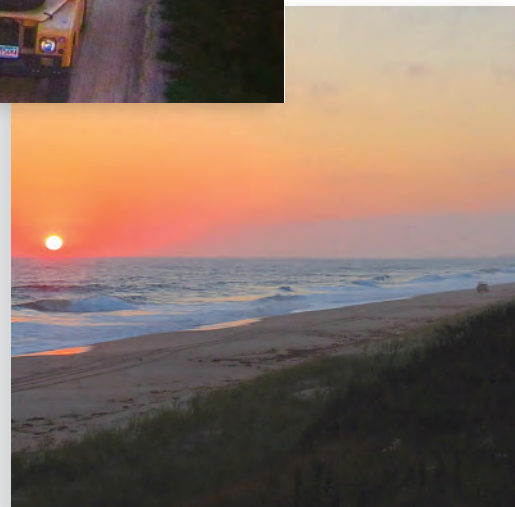



Behind the Steering Wheel

Story and photos by Jeffrey Aronson



"We wanted an adventure." Eschewing common sense, they turned to Ebay and lost out on bids for a Ford Bronco II and a VW Super Beetle convertible. Then their MGB beckoned them in Syracuse, NY.

It looked like fun and the top bid sat at \$2,100. If you've trolled Ebay, you know the ads get a little hyperbolic. This seller merely claimed, "It runs, drives and stops," and that, "Most of the gauges work."

He'd owned the car for only a couple of months and had not added to its 91,000 miles. Felipe remembered that, "We must have asked 20 questions and he answered two." After "winning" the bid, they hopped on a bus to pick up their new cross country car.

Felipe and Briston had a limited travel budget and thus limited drive time. They stopped at Peter Cosmides' MotorCar Garage in New Jersey while on their way south. Between the online network of Land Rover and MG enthusiasts, minor foibles were handled

easily and they enjoyed their trip

through Florida, and then west to California. Oh, and after they arrived in the Napa Valley, they decided to take a Labor Day weekend side trip to Vancouver, BC via Portland, Eugene and Seattle. The MGB has not had any significant work since its purchase 5,000 miles ago, and now serves the poster child for their new business, Vineyard Tales (www.vineyardtales.com).

A couple with no automotive experience whatsoever bought a hardscrabble, 91,000 mile,



45-year-old MGB with no service history and took it 5,000 miles cross country. So yes, you can—and should—take that new-to-you Land Rover anywhere.

One Christmastime some members of the very informal Downeast Land Rover Club met at the Sebago Brewpub [surprise!] just outside of Portland, ME. I invited Dave Michaud and Shelby Johnson, who had just purchased a '97 Discovery, to join us. Dave and Shelby really loved the Discovery, purchased after local enthusiast Bob Vail had crawled all over it, but wondered about an upcoming trip to Keene, NH. "It has around 100,000 miles," said Dave. "I'm nervous about taking it on such a long trip."

Heads turned around the table. I mean this is a group that has rebuilt a Series Land Rover over a couple all-nighters and then headed out hundreds of miles to off-road events. In terms of overall condition and mileage, Dave and Shelby's Discovery stood far above those driven to the pub. Any one of us would have taken that Discovery way beyond the 300 mile round trip to Keene.

Their question was a common one. If Santa brought you your first "new-to-you" Land Rover, it likely came with high mileage and a general air of "what might go wrong next?" Unless your mechanic's, or mechanical friend's examination [you did have someone knowledgeable look over the Rover first, right?] showed obvious flaws, the only way to find out is to drive it. Fearful of a breakdown? Think about this story first.

Last July I met Felipe McAlister and his girlfriend, Briston Sullivan, both 26, at Leyland British in Kennebunkport, ME. I watched them crawl out of a rough '70 MGB, stuffed with luggage, four new tires, and running New York license plates. Their MGB had wire wheels and proprietor Erick Van Sickle knew how to mount tires on them. Figuring the couple might be summer residents, I asked where they were headed. "Napa Valley, California," Felipe replied. That's cross country in "Penny," a 45-year-old, British Leyland-era MGB.

Since they lived in New York City, they'd never owned or worked on a car. Felipe had left his job as a proprietary bond trader and Briston had left hers in advertising and marketing. They spent four months traveling through Asia before deciding to start their new lives in California's wine industry. They decided to buy their first car together because,

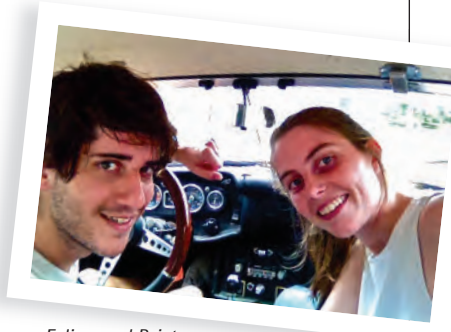

Felipe and Briston





Until recently, my Series II-A had suffered the slings and arrows of island wisecracs alone. Then, to my delight, a Series III 109" ex-military showed up with its owners, Ryan and Alyson Flemming, both chefs at a new restaurant. It also provided fodder for a new wisecrac, restaurant staffer and volunteer EMT Jessie Cochran. She spied the two Land Rovers in a parking lot and in a snarky voice pronounced, "they look cute together."

When not creating outstanding dishes, Ryan likes to work on his Land Rover. But a chef's schedule and Maine weather don't leave much leeway for basic maintenance. Of course, the moment I saw his Land Rover and found out about their move, I introduced myself and offered assistance.

Generally speaking, when I "offer assistance," experienced Land Rover enthusiasts run for the hills. For someone who thinks he knows a lot about Land Rovers, I've chronicled a lot of breakdowns and outdoor repairs. Ryan, however, did not know better when he called to see if I could assist him on changing out a brake line. I had visions of something simple, but since his Series III had the dual circuit brake system, replacing a front brake line—in a dirt parking lot—proved to be a bigger headache. Once uncoiled, the new brake line from the shuttle valve to the wheel cylinder could be shaped into the weird curves required, but for some reason his shuttle valve had a larger threaded hole than the screw-in fitting that came pre-installed on the Genuine Land Rover part. We would need to cut off the old fitting and have it flared onto the new brake line.

Here was a chance to introduce Ryan to the quirks of small island living. We have three auto mechanics, two full-time and one part-time. One had closed up for a medical appointment, one was out lobstering, but Jacob had the right sized flaring tools and did the job for \$10. I slid under the Land Rover and buttoned everything up. Happily, it did not take many pumps to bleed the system effectively.

While the Rover would stop quickly, a week later it would not start. The battery ran down churning the starter motor and did not seem to hold a charge. Along with the spark plugs, the battery had been replaced a year ago. A multimeter showed that the battery had 12.3 V, but that it quickly fell below 12 V with just a few turns of the key. What would drain the battery that quickly? A bad starter would, but fortunately, I discovered the battery simply had little water covering the plates. Now onto problem #2. When we hooked up jumper cables, it cranked but would not fire. So I pulled the cap and rotor [both looked ok] and had Ryan fire up the engine. The points never opened or closed—time to set the points. Using his hand crank, we turned the distributor shaft until the points rested on a cam lobe. After gapping them with a feeler gauge it fired right up—and sounded quite smooth. Ryan said it had never started that easily. I was just relieved that I didn't make anything worse. Two days later I breathed a sigh of relief

when I saw his Land Rover in a different location—yes, it actually moved and for a change my repair had worked!

So now my brake lights stay on whenever the ignition is on—here's hoping that repair will be as simple.

Responding to an EMS call last winter, a friend's SUV slid into a ditch. As it was on a remote part of the island with no cellphone service, she appreciated the OnStar service that came with her car so much that she wound up appearing in an advertisement for General Motors. This incident popped back into my head as I read again of the increasing connectivity between contemporary vehicles and the internet. Consumers expect more than maps and music from their in-car hard drives they want the information and applications that arrive via the internet. They're spending more time in their vehicles than ever before and they're demanding greater connectivity. Then there's the other push from US government agencies that want to require vehicles to send messages to each other in an effort to reduce accidents. As one tech expert noted, when you enter your vehicle, "You're stepping into a rolling computer now."

Land Rover has come up with an interesting feature for contemporary motorists. Starting later this year with the Range Rover and Range Rover Sport (and later with all models except the LR2), you can order the *InControl Remote* and *InControl Protect* systems for your Land Rover. They run through built-in SIM cards and as an app available for Android or Apple phones. Inside the car you'll find a button for an "SOS Emergency" call, or the system will initiate it automatically in the event of an airbag deployment [dependent upon phone coverage]. And, "in the unlikely event of a breakdown," Land Rover has included a button on the overhead console (or directly from your phone app) that will provide "optimized roadside assistance." The GPS will let the system know of your location.

Among the remote features in the app will be the ability to determine whether the doors and tailgate are locked, the amount of fuel in the tank, the available range, directions to your car if you've parked in an unfamiliar area, low tire pressures or low washer fluid. The app can also track mileage for those pesky business expense accounts. For those who don't want to be tracked, the system does not transmit your location unless an accident occurs or you call roadside assistance.

My Series II-A becomes a "rolling computer" anytime I bring my laptop back with me. Marginal cellphone service leaves me with a "dumbphone" that identifies my location as "lost." I never lock the doors and you know when the tailgate is closed by the Jacob Marley-like rattling of the chains. As for tracking mileage, well, first I need an expense account. Lastly, if I wanted to remain anonymous, I wouldn't drive a Series Land Rover. ■■■



1986 - 2011
BB4WA
25 YEARS!

Bill Burke's 4-Wheeling America LLC
Premier Training - Guided Back Country Trips & Expeditions
570-858-3468 www.bb4wa.com

4-Wheel Drive Off-Road Safety Training for industry, government and recreation. Private training available.
Visit www.bb4wa.com for dates and locations of our trips, expeditions, adventures and training classes.



Burke's Corner

[Bill Burke, Grand Junction, CO, one of the foremost off-road instructors in North America, offers his advice on selection of cold weather supplies —ed.]



Cold Weather Awareness



Why, on the coldest days of the year, do we resolve to do anything except sit around the fire watching the wood burn? Some readers in Key West or similar locales will watch sail boats float by or polar bears cavort at the San Diego Zoo. The rest of us will prepare for the very real chance that the ice we see will not be floating in a cocktail glass but underneath the tires of our Land Rovers.

Cold weather demands changes in our off road rituals. I've got my tire snow chains all ready for use; my warm gloves, extra heavy duty long undies, over-pants and my Loki protective gear all sorted—and it's not just because the plastic windows don't fit the top of the Defender anymore. I've got my Bug-Out-Bag changed over for the winter season and the winter "survival can" packed into the back of each Land Rover.

Public Service Announcements often remind us of the simple things to keep us safe if that feared incident happens; for example, the slide into the ditch, the snow plow buries our car and we have to survive on our wits and whatever's inside in the Rover. Simple things like a sleeping bag/wool blanket, coat, gloves, socks, emergency radio, jumper cables, flares, spare fuel, shovel, those cool little hand warmer thingies will make all the difference. There's no such thing as bad weather—just insufficient gear and poor choices in clothing.

If hiking out immediately is not an option, survival can depend as much on the way in which we utilize the terrain as on the materials a traveler has available. We can live three weeks without food, three days without water, but only a few hours without shelter. Shelter and water are more important than food—stay with the vehicle if possible. Think again before you leave the shelter of your Rover. Don't forget to clear the snow from your tail pipe. Keep the radiator and engine compartment free of clogging snow, slush and debris. I have seen snow packed engines overheat in extreme low temps—yes, overheat.



A simple homemade survival kit can be packed into an empty 3 pound coffee can, or some nesting camping pot with a strong-sealing lid. The can, in addition to being a container for the survival supplies, could be an improvised kettle for melting snow and/or heating food! In an emergency, before you fill the can, punch three holes around the top edge of it in a triangular pattern. By fastening a cord, string or wire

(stored inside the can) through the punched hole, it can be used to melt snow, heat soups and water if stranded. You could, for example, hang the can from the rear view mirror and leave enough string



so a candle or canned heat on the dashboard, transmission hump, or center console, directly under the can will heat its contents. Of course, modern technology gives us the Esbit folding stove, Tommy Cooker or the Jetboil (Be aware of CO poisoning and ventilate any flame)

This kit should be inside the vehicle as the trunk or door could be jammed by collision or buried in the snow.

Keep these supplies in the can:

- * Matches, several 'hurricane' candles and/or canned-heat
- * Small sharp knife or multi-tool
- * Facial tissue, paper towels and toilet paper
- * Large size plastic garbage bags (use for rain or wind protection, or as a container) Also you can cut a hole in the bottom large enough for your head and wear it as a poncho.
- * Safety pins, spoon/spork, aspirin (labeled), pencil stub, plastic whistle (note: whistles are 'directional'—use your hands to help direct, and the hole is to drain your spit—so the hole usually goes down!)
- * Flashlight (non-metal) with batteries kept outside of the flashlight to avoid corrosion. Batteries work best if they are warm, by the way.
- * Tape coins under the lid for payphone calls or vending machines and fold a bunch of dollar bills in there.
- * Compass—even a toy one works to point north
- * Small wire and/or string, or parachute cord
- * Small roll of duct tape, rolled up 'survey' tape
- * Snacks to nibble on to help keep morale up, semi-sweet chocolate, raisins in small packages, energy bars like Lara/Cliff, wrapped hard candy, honey sticks, instant broth/soup packs, canned meat/tuna.



Remember that the stored can and its contents will be exposed to the elements—freeze/thaw cycles—while in the vehicle over time. Do not include items that will be compromised by this action or that may burst open.

In addition to the above items, mittens, scarf and stocking cap may be tied around the can with 50 or more feet of parachute cord or strong nylon string. If you must leave the Rover the cord can be tied to the vehicle and then, to yourself, so you can find your way back.

This kit and these suggested items should provide you with a starting place; you will need to add your own spin on this kit. Things like water filters, first-aid kit, communications devices and locator beacons are all good ideas to have along. Things that rely on batteries will eventually run down... don't count on technology for survival. Count on yourself, your learned skills and common sense.

People talk about using the bonnet of a Rover for shelter or transportation but that requires you have to have tools to remove it. You must also have the strength, energy, and ability to remove the bonnet. Don't be fooled by those TV shows. If you are really intrigued by learning solid survival skills check out the Boulder Outdoor Survival School in Utah or look into some of the National Outdoor Leadership School courses or some of the "bush craft" schools like Jack Mountain in Maine.

Staying with the vehicle is the smart thing. It is the easiest to find and can be a source of survival items. Tie a bright cloth or surveyors tape on the top most antenna, or use a stick attached to the body so it can be seen above the potential snow drift the vehicle may end up looking like! Even a Hi-Lift jack handle can be used to allow fresh air to move about. Your survival will depend on you remaining calm, exercising caution and being patient.

Assess the immediate environment for its utility. Trees provide wood for fire and shelter. Tall grasses or shrubs become natural wind breaks. If there's the potential for avalanches, resist the temptation for open country travel. Prioritize your actions in order of importance: shelter, water, warmth.

Eating snow can be dangerous for survival. Snow will chill you if eaten cold. If it can't be heated, put it in a cloth and let the moisture soak through and sip or drink that. Too much cold snow in your mouth can cause stomach cramps. Stay away from alcohol and/or soda. They increase dehydration and the short term warmth is not worth it.

Again, be patient—just hunker down for the night or duration. Maybe that headliner will finally get pushed back into place! Time will



pass and it will be safer in the daylight to re-assess your situation. Make sure your Rover is running righteous, has the good stuff recovery gear and is always ready "to go" when the stuff hits the fan! Make sure your spares kit is up to snuff also. Remember that chance favors the prepared mind!

There, whew, my first completed resolution of the new year... get this column wrapped and in the can! Looking forward for another great year with you wonderful Roverphiles! Take care, Happy New Year, see you on the trail! BB //

[For more information on Bill Burke's 4-Wheeling America, visit www.bb4wa.com —ed.]

NEW Optilux LED Work Lamps by Hella

Features; compact round design, 9 high performance LEDs, Aluminium die-cast housing and PC lens.



NEW Optilux 5 Round LED Close-Range
4.3" dia x 5" h x 2.1" l
H71030101 \$ 39.95 ea
Long-Range
H71030201 \$ 39.95 ea



NEW Optilux 5 Square LED Close-Range
4.3" w x 5" h x 2.1" l
H71030301 \$ 39.95 ea
Long-Range
H71030401 \$ 39.95 ea



NEW Optilux 5 Round Rubber LED
Features; round design, 6 high performance LEDs, rubber housing and PC lens. 4.9 dia. x 2.9" l
H71030501 \$ 48.50 ea

Hella Work Lights for your Roof Rack



HELLA Flexible Interior Map Light
Flexible attachment provides reading for both occupants. Perfect for reading maps! Plugs into any 12v lighter receptacle.
RNA671 \$ 49.50



Defender Body Armor

The finest in protection for your Defender. High quality 3 mm 5 bar protection plate, anodized Silver or Powder Coated Black. Fits all Defenders up to 2007.



6 Bumper Top Tread Plates
Bumper Top Tread, Silver.....RNA6540 \$ 29.50
Bumper Top Tread, Black.....RNA6540B \$ 35.00
Rear Cross Member Chequer Plate ..RNA6554B \$ 99.95



5 Chequer Plate Middle Door 110
Includes stainless hardware.
Defender 110, Black
RNA6541B \$ 74.50
Defender 110, Silver
RNA6541 \$ 74.50



1 Bonnet Protection Plate
Includes stainless hardware.
Defender up to '07, Black.....RNA6520B \$ 211.00
Defender up to '07, Silver.....RNA6520 \$ 199.00
Defender Puma 2007 on, Black.....RNA6511B \$ 498.00

2 Wing Top Protector Sets
Includes stainless steel hardware - Sold in pairs.
Up To 2007, with left hand aerial hole
Defender Anodized Silver.....RNA6510 \$ 189.00
Defender Powder Coated Black.....RNA6510B \$ 199.00
Gasket Wing Top Protector, pair.....RNA6510G \$ 29.95
Puma 2007 On
Defender 2007 on, Silver.....RNA6555 \$ 169.00
Defender 2007 on, Black.....RNA6555B \$ 169.00

3 Rear Corner Protectors
Includes stainless steel hardware - Sold in pairs.
Defender 90, Black.....RNA6550B \$ 76.95
Defender 90, Silver.....RNA6550 \$ 74.50
Defender 110, Black.....RNA6551B \$ 89.50
Defender 110, Silver.....RNA6551 \$ 89.50
Defender 110 Puma '07 on, Black.....RNA6512B \$ 84.50

4 Sill Protectors
Includes stainless steel hardware - Sold in Pairs.
Defender 90, Black.....RNA6530B \$ 159.00
Defender 90, Silver.....RNA6530 \$ 139.80
Defender 110 SW, Black.....RNA6531B \$ 159.00
Defender 110 SW, Silver.....RNA6531 \$ 159.00

Chequer Plate Complete Kits
Defender Aluminum 5 Bar Body Protection Kit non-fade electrostatic finish. Non-fade Powder Coated Silver or Black. Reinforce your body work with these G4 Style 5 bar protection plates. Made from non-corrosive aluminum alloy.
Complete Kit includes: Wing top protectors, sill protectors, quarter protectors and stainless steel hardware. Non-fade powder coated.
Defender 90, Silver.....RNK6500 \$ 349.00
Defender 90, Black.....RNK6500B \$ 369.00
Defender 110, Silver.....RNK6501 \$ 379.00
Defender 110, Black.....RNK6501B \$ 389.00

Safety First - Clear Vision on Wet Days with New Wiper Blades!

Wiper Blades

Series IIA, III Wiper Blade, 5 mm, ProLine	PLD285	\$ 5.95
Series IIA, III Wiper Blade, 7 mm, Genuine	RNF238	\$ 13.95
Series IIA, III Wiper Blade, 7 mm, ProLine.....	PLF238	\$ 8.95
Series IIA, III Wiper Blade, independent wiper w/orig hook arm.....	PLE612	\$ 17.50
Series IIA, III Wiper Arms and Blades Kit.....	PLK819	\$ 25.95
Defender 90, 110, Wiper Blades, Front or Rear, Genuine	RNC948	\$ 16.95
Defender 90, 110, Wiper Blades, Front or Rear, ProLine.....	PLC948	\$ 6.90
Discovery I 1994-'99, Front Wiper Blade, Genuine	RNW116	\$ 12.95
Discovery I 1994-'99, Front Wiper Blade, ProLine.....	PLW116	\$ 5.99
Discovery I 1994-'99, Front Wiper Blade with spoiler (driver's side), Genuine.....	RNW117	\$ 13.95
Discovery I 1994-'99, Front Winter Blade, Genuine.....	RNH875	\$ 14.95
Discovery I 1994-'99, Rear Wiper Blade, Genuine.....	RNW103	\$ 15.49
Discovery I 1994-'99, Rear Winter Blade, Genuine.....	RNF166	\$ 17.80
Discovery I 1994-'99, Winter Wiper Blade Set of 3, Genuine.....	RNW112	\$ 42.99
Discovery II 1999-'04, Front Wiper Blade, Genuine	RNW113	\$ 23.99
Discovery II 1999-'04, Front Wiper Blade, ProLine.....	PLW113	\$ 13.99
Discovery II 1999-'04, Front Winter Blades (Pair), Genuine.....	RNH876	\$ 89.95
Discovery II 1999-'04, Front Winter Blades (Pair), Genuine.....	PLH876	\$ 55.95
Discovery II 1999-'04, Rear Wiper Blade, Genuine.....	RNW100	\$ 15.99
Discovery II 1999-'04, Rear Wiper Blade, ProLine.....	PLW100	\$ 8.97
Discovery I 1994-'99, Rear Winter Blade, Genuine.....	RNF166	\$ 17.80
Discovery I 1994-'99, Winter Blade Set of 3, Genuine.....	RNK9142	\$ 94.50
Discovery II Wiper Blade Conversion, Front, ProLine	PLK9141	\$ 41.95



RR Classic 1987-'89, Front or Rear Wiper Blade, ProLine	PLW104	\$ 6.95
RR Classic 1990-'95, Front or Rear Wiper Blade, Genuine.....	RNW111	\$ 14.50
RR Classic 1990-'95, Front Winter Blade, Genuine.....	RNH875	\$ 14.95
RR P38A 1995-'02, Front Wiper Blade, Genuine	RNW107	\$ 29.95
RR P38A 1995-'02, Front Wiper Blade, ProLine.....	PLW107	\$ 10.95
RR P38A 1995-'02, Front Winter Blade, ProLine.....	PLW107W	\$ 25.15
RR P38A 1995-'02, Rear Wiper Blade, Genuine.....	RNW118	\$ 19.95
RR P38A 1995-'02, Rear Wiper Blade, ProLine.....	PLW118W	\$ 15.70
RR P38A 1995-'02, Headlamp Wiper Blade, Genuine.....	RND223	\$ 19.95
RR P38A 1995-'02, Winter Wiper Blade Set of 3, ProLine.....	PLW109	\$ 59.80
RR L322, 2002-'09, Front Wiper Blade, Genuine	RNH780	\$ 28.90
RR L322, 2002-'09, Front Wiper Blade, ProLine.....	PLH780	\$ 12.95
RR L322, 2002-'09, Rear Wiper Blade, Genuine.....	RNJ438	\$ 44.95
RR L322, 2002-'09, Rear Wiper Blade, ProLine.....	PLI126	\$ 12.95
RR L322, 2002-'12, LHD, Winter Wiper Blade Set of 3, Genuine.....	RNQ905	\$ 89.95
RR Sport, 2005-'09, Front Wiper Blade, Genuine	RNH781	\$ 39.95
RR Sport, 2005-'09, Front Wiper Blade, ProLine.....	PLH781	\$ 19.95
RR Sport, 2005-'09, Rear Wiper Blade, Genuine.....	RNI747	\$ 49.95
LR3, 2008-'10, Front Wiper Blade, Genuine	RNH781	\$ 39.95
LR3, 2008-'10, Front Wiper Blade, ProLine.....	PLH781	\$ 19.95
LR3, 2008-'10, Rear Wiper Blade, Genuine.....	RNI355	\$ 24.95
LR2, 2008-'10, Front Wiper Blade, Drivers side, Genuine	RNI742	\$ 29.95
LR2, 2008-'10, Front Wiper Blade, Passenger side, Genuine.....	RNI743	\$ 39.95
LR2, 2008-'10, Rear Wiper Blade, Genuine.....	RNI744	\$ 28.95

Land Rover Mud Flaps

Range Rover Classic

Front or Rear (each) flap only.....	RNA652	\$ 27.95
-------------------------------------	--------	----------

Range Rover P38A

4.0 / 4.6, Front pair, molded.....	RNB301	\$ 315.54
4.0 / 4.6, '95-96, Rear pair, molded.....	RNB308	\$ 198.95
4.0 / 4.6, '99-on, Rear pair, molded.....	RNB317	\$ 189.95

L322 Range Rover

Mudflap Kit Rear Pair, Genuine.....	RNI401	\$ 139.95
-------------------------------------	--------	-----------

Range Rover Evoque

Mudflap Kit Front Standard Evoque.....	RNQ906	\$ 137.90
Mudflap Kit Rear Standard Evoque.....	RNQ907	\$ 137.90

Discovery I

Front pair with hardware styled w/logo, flexible, Genuine.....	RNA648	\$ 97.95
Front pair with hardware, plain, flexible, ProLine.....	PLA648	\$ 24.50
RH, Front flap only, flexible.....	RNH931	\$ 27.50
LH, Front flap only, flexible.....	RNH930	\$ 27.50
Rear pair, w/hardware, flexible, Genuine.....	RNA649	\$ 79.95
Rear pair, w/hardware, flexible, ProLine.....	PLA649	\$ 24.50

Discovery II

RH, flap only (each) Front or Rear, molded.....	RND231	\$ 44.95
LH, flap only (each) Front or Rear, molded.....	RND232	\$ 39.95
Front Mud Flap Kit Discovery II.....	RNQ818	\$ 209.30

Series 88, 109 Regular

Rear pair, styled w/logo, flexible.....	RNB704	\$ 84.90
Front, without logo, flexible, ProLine.....	PLI557	\$ 39.95



LR2

Front pair with hardware, molded.....	RNI687	\$ 139.95
Rear pair with hardware, molded.....	RNI688	\$ 149.95

LR3 up to '09

Front pair with hardware, molded.....	RNI691	\$ 129.95
Rear pair with hardware, molded.....	RNI692	\$ 129.95

Defender 90 NAS

Rear pair with hardware. Features stainless steel mounting brackets and hardware.....	RNK015	\$ 159.00
LH Rear with hardware, flexible (fits non-NAS Defender 90 only).....	RNI682	\$ 49.96
RH Rear with hardware, flexible (fits non-NAS Defender 90 only).....	RNI683	\$ 57.23

Defender 90, 110

Front pair, with hardware, without logo, flexible.....	RNF252	\$ 149.95
Mudflap Kit - Front Pair Defender.....	PLF252	\$ 89.95
LH front with hardware, flexible.....	RNI426	\$ 59.95
RH front with hardware, flexible.....	RNI684	\$ 58.55

Defender 110

LH Rear with hardware, flexible.....	RNI685	\$ 59.95
RH Rear with hardware, flexible.....	RNI686	\$ 59.95
Rear pair, styled w/logo, flexible, with all hardware.....	RNK014	\$ 124.55
Rear mudflap, single w/Land Rover oval logo.....	RNL313	\$ 49.27

DEFENDER Front Trim



- 1. Grille Front**, Graphite (Black) Plastic, Genuine.....RNC842 \$ 94.95
 Grille Front, Graphite (Black) Plastic, ProLine.....PLC842 \$ 29.95
 Grille Front, Brunel (Silver as shown) Plastic, Genuine.....RNS852 \$ 168.00
 - 2. Grille Badge "Land Rover"** Oval Defender Silver.....RNQ878 \$ 109.95
 Grille Badge Clip on, Land Rover, Green & Gold, Genuine .RNI563 \$ 25.95
 Grille Badge Clip on, Land Rover, Green & Gold, Genuine .RNQ184 \$ 18.11
 Land Rover Badge Stick on, Green & Silver, Genuine.....RNQ185 \$ 31.95
 Land Rover Badge Stick on, Green & Gold, Genuine.....RNB318 \$ 29.95
 - 3. Bezel, LH**, Graphite Black, '95 & '97 NAS Only.....RNC900 \$ 44.85
 Bezel, RH, Graphite Black, '95 & '97 NAS Only.....RNC899 \$ 44.85
- All Defender Models Except '95 & '97 NAS**
- Bezel, LH, Graphite Black w/vents, '99 on.....RNL430 \$ 119.95
 Bezel, LH, Graphite Black w/vents, '99 on.....PLL430 \$ 19.99
 Bezel, LH, Brunel Silver (shown) w/vents.....RNS851 \$ 159.95
 Bezel, LH, Graphite Black w/o vents, pre '95.....RNC928 \$ 68.95
 Bezel, LH, Graphite Black w/o vents, pre '95.....PLC928 \$ 14.96
 Bezel, RH, Graphite Black w/vents.....RNL429 \$ 119.95
 Bezel, RH, Graphite Black w/vents.....PLL429 \$ 19.99
 Bezel, RH, Brunel Silver (shown) w/vents.....RNS850 \$ 159.95
 Bezel, RH, Graphite Black w/o vents, pre '95.....RNC929 \$ 68.95
 Bezel, RH, Graphite Black w/o vents, pre '95.....PLC929 \$ 14.96

- 4. Intake Finisher LH Wing Top Open Grille**, Genuine.....RNS604 \$ 19.43
 Intake Finisher LH Wing Top Open Grille, ProLine.....PLS604 \$ 6.95
 Intake Finisher LH Wing Top Blank, Genuine.....RNS829 \$ 21.21
 Intake Finisher RH Wing Top Open Grille, Genuine.....RNC903 \$ 12.95
 Intake Finisher RH Wing Top Open Grille, ProLine.....PLC903 \$ 7.95
- 5. Puma Bonnet**, Upgrade to a stronger bonnet for more engine room.
 Fits All Defender models. Bonnet is slightly wider and may interfere with non-Puma wing top protector sets. Modify or use Puma wing top protectors, see page 36, Genuine.....RNH858 \$ 895.00
- 6. Decal Bonnet "DEFE"**, Brunel.....RNQ645 \$ 46.95
 Decal Bonnet "DEFE", Black.....RNQ879 \$ 56.95
 Decal Bonnet "NDER", Brunel.....RNQ646 \$ 46.95
 Decal Bonnet "NDER", Black.....RNQ880 \$ 56.95
 Decal Bonnet "LAND" Defender Silver '07+.....RNN976 \$ 59.95
 Decal Bonnet "LAND" Defender Gloss Black.....RNN974 \$ 39.95
 Decal Bonnet "ROVER" Defender Silver '07+.....RNN977 \$ 69.95
 Decal Bonnet "ROVER" Defender Gloss Black.....RNN975 \$ 39.95

7. Front Bumper End Cap

Nice looking rugged rubber finisher that offers pedestrian protection from the rearward metal edge. Sold as each. Will fit right or left side. Requires qty. 4 of fastener RNS524.
 FITS: Defender front bumper all models 1984-2015 and Rovers North HD winch bumper (RNA110B). **RNS523 \$ 39.90**

Fastener Bumper End Cap Defender RNS524 \$ 2.01
End Cap Kit Front Bumper Defender Style

Kit includes 2 bumper end caps with fasteners, Genuine.....RNK8621 \$ 89.95



ROW Style w/ horn vent



NAS Style '95 & '97 w/o horn vent

To fit ROW style bezels to NAS '95 & '97 models (or visa versa), requires replacing indicator lamp with RoW style lamp. See our selection listed on page 77.



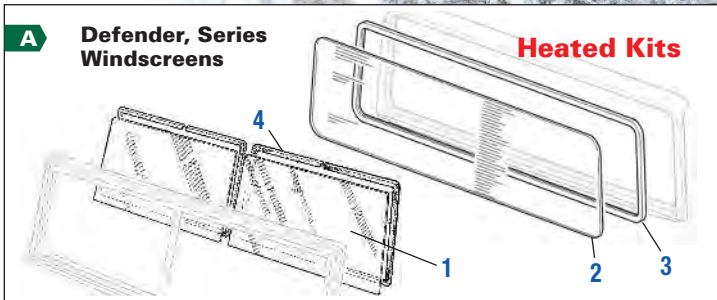

A Defender, Series Windscreens

Heated Kits



A Windscreens

1. SERIES GLASS HEATED SERIES II-III, RH.....	PLB962R	\$ 229.95
SERIES GLASS HEATED SERIES II-III, LH.....	PLB962L	\$ 229.95
SERIES WINDSCREEN GLASS LAMINATE SERIES II-III.....	PLE319	\$ 89.95
HEATED WINDSCREEN KIT SERIES II-III NEGATIVE EARTH.....	PLK852	\$ 549.00
2. DEFENDER CLEAR HEATED w/BOTTOM POWER, GENUINE.....	RNI134	\$ 515.09
TINTED HEATED w/BOTTOM POWER CONNECTION, PROLINE.....	PLI134	\$ 379.00
DEFENDER CLEAR NON-HEATED, GENUINE.....	RNE299	\$ 389.77
DEFENDER TINTED NON-HEATED, GENUINE.....	RNE304	\$ 439.22
DEFENDER TINTED NON-HEATED, PROLINE.....	PLE304	\$ 179.00
DEFENDER TINTED HEATED w/BOTTOM POWER, GENUINE.....	RNI113	\$ 723.65
DEFENDER CLEAR HEATED w/TOP POWER, GENUINE.....	RNC927	\$ 998.95
HEATED WINDSCREEN KIT DEFENDER.....	PLK8521	\$ 569.00
3. SEAL WINDSCREEN GLASS-FRAME DEFENDER, GENUINE.....	RNE362	\$ 154.38
SEAL WINDSCREEN GLASS-FRAME DEFENDER, PROLINE.....	PLE362	\$ 36.50
4. GLAZING SEAL 50 FOOT ROLL.....	GT106	\$ 13.95
DEFENDER REAR GLASS - HEATED REAR WINDOW, GENUINE.....	RNB054	\$ 369.00
DEFENDER REAR GLASS - HEATED REAR WINDOW, PROLINE.....	PLB054	\$ 134.90



KBX DEFENDER Grille Set

Includes Headlamp Bezels and Center Grille with Stainless Steel premium diamond pattern woven backing for the grille panel as shown. Choose between Satin Black or Brunel Silver. Land Rover Badge sold separately. **Note: Does Not fit NAS Lights.**

- KBX Grille Facia Kit, Satin Black....KBX3121 \$ 399.99**
- KBX Grille Facia Kit, Brunel Silver.KBX3421 \$ 529.00**
- Land Rover Badge Green-Gold.....RNB318 \$ 29.95**
- Land Rover Badge, Black-Silver.....RNQ474 \$ 14.95**

For additional lighting see page 78.

KBX Single Lamp Guards

are easily fitted to all NAS style lamp assemblies as supplied on 1995 and 1997 Defender NAS models. They are supplied as a pair with stainless steel screws to allow fitting on existing NAS plinths. **Lamp Guard Pair, Defender, Satin Black KBX7101 \$ 41.99**



KBX Multi Lamp Mount Set for Rear NAS Defender Lights

Kit includes 2 ABS rear mounts for 3 NAS style lamps (not included in kit), 2 grade A red reflectors and stainless steel mounting screws. Finished in Satin Black. Use KBX8101 for matching lamp guard set.

- Satin Black **KBX9101 \$ 119.99**
- Brunel Silver **KBX9401 \$ 129.99**



KBX Lamp Guard Set for Defender Rear KBX Multi Lamp Mount

Rear multi mount KBX lamp guard set. Kit includes 2 lamp guards and stainless mounting steel screws. **Brunel Silver KBX8401 \$ 98.50**
Satin Black KBX8101 \$ 69.90

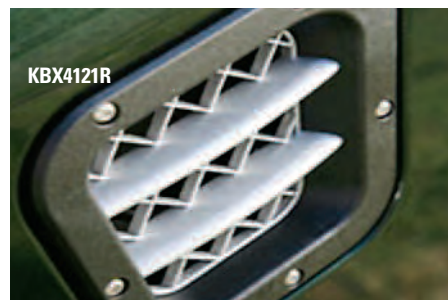

KBX Defender Sport Side Air Intakes.

Suitable for: (L) TD, 200 TDi, (R) 300 TDi, TD5 and TDci/Puma Defenders.

- Standard, Satin Black, LH.....KBX4111L \$ 109.95**
- Standard, Satin Black, RH.....KBX4111R \$ 109.95**
- Premium, Brunel Silver/Java Black...KBX4431L \$ 139.00**
- Premium, Brunel Silver/Java Black....KBX4431R \$ 139.00**
- Premium, Satin Black/Brunel Silver....KBX4121L \$ 119.95**
- Premium, Satin Black/Brunel Silver....KBX4121R \$ 119.95**



KBX Hi-Force Wing Top Set

- Satin Black **KBX5101 \$ 123.95**
- Brunel Silver **KBX5401 \$ 144.50**

Chassis – DEFENDER

Introducing our new selection of Defender galvanized chassis, packed with all the improved features found on the latest Defender. Built on factory jigs for accuracy and hot dipped galvanized for long corrosion resistant life. Now is the time to build your ultimate Defender.

Replacement Rear Body Supports
Bed Rail Rear Body All Series and Defender,
 except HICAP, GenuineRND147 \$ 49.95
Rubber Pad for Rear Bed Rail..RND148 \$ 6.95
Rivet for Rubber PadPLC690 \$ 0.45
Crossmember Middle Floor Defender 110 SW,
 Genuine.....RNQ908 \$ 105.96



NAS rear cross member

Optional on 90 chassis, as fitted to NAS Defenders.

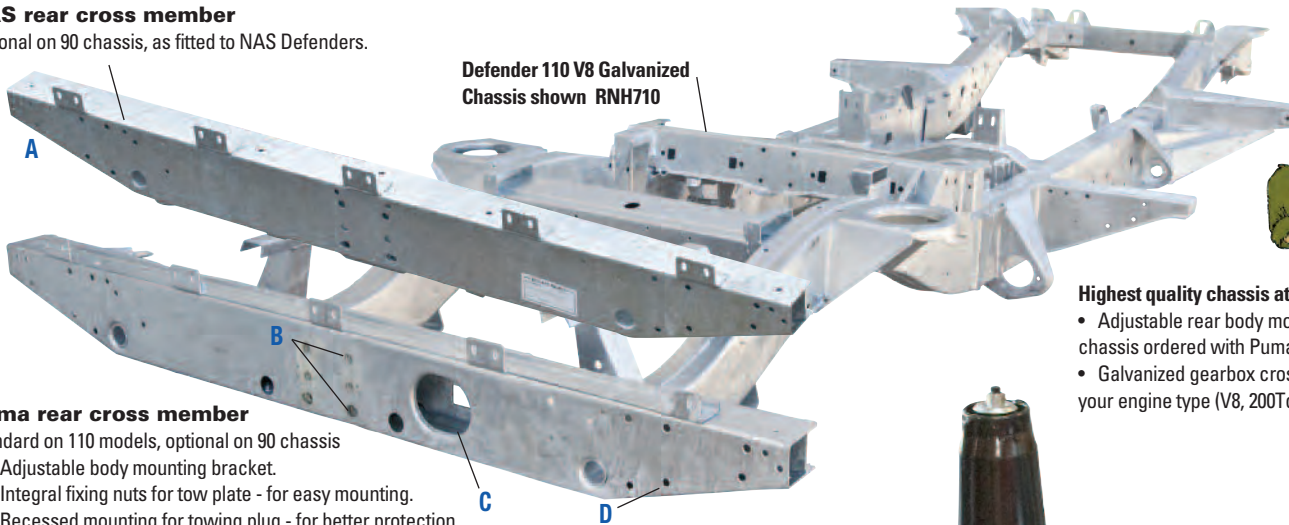

Defender 110 V8 Galvanized Chassis shown RNH710



Highest quality chassis at the best prices

- Adjustable rear body mounting bracket on chassis ordered with Puma rear cross member.
- Galvanized gearbox cross member to match your engine type (V8, 200Tdi/NA, 300Tdi).

Puma rear cross member

Standard on 110 models, optional on 90 chassis

- A. Adjustable body mounting bracket.
- B. Integral fixing nuts for tow plate - for easy mounting.
- C. Recessed mounting for towing plug - for better protection.
- D. Bottom mounting blocks for rear NAS step.

Replacement Rear Cross Members



Replacement Rear Cross Member NAS 90

Direct weld-on replacement rear quarter chassis section for all NAS 90 models. Improved features included: Expanded slide over ends for easy alignment and improved welding. 3mm thick steel for a heavy duty, stronger than stock rear frame member. Hot dipped galvanized for superior corrosion resistance. Make the UK. FITS: Defender NAS 90 all models 1994 - 1997

PLH61990NASHD \$ 979.00

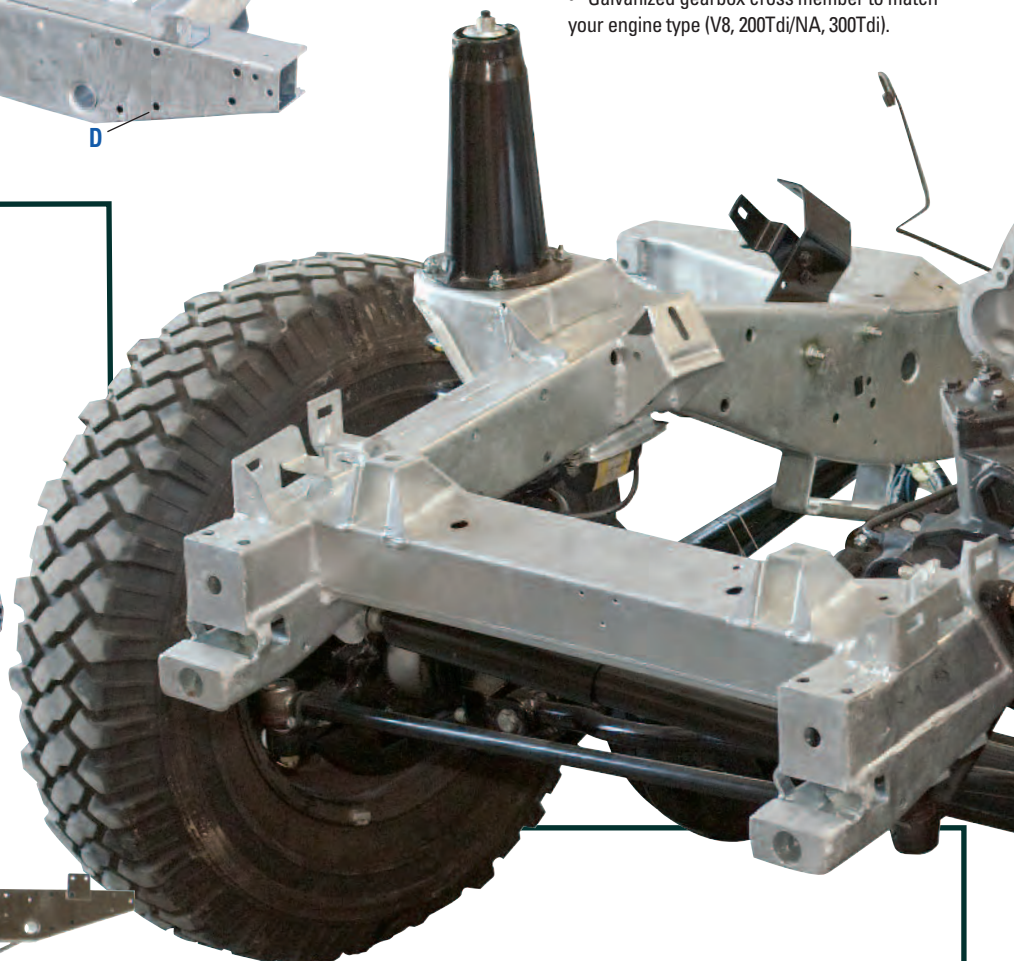

Defender 90

PLH61990HD

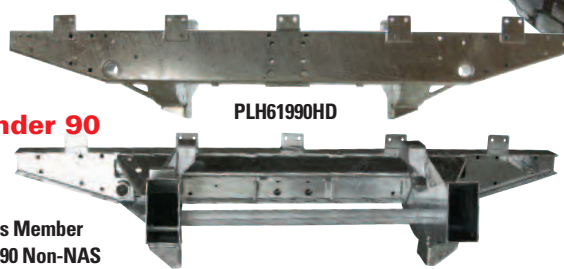

Rear Cross Member Defender 90 Non-NAS

For 90s with side fuel tanks. Don't just repair your chassis, improve it. Made with 3 mm thick steel for extra strength. Hot dipped galvanized for superior corrosion resistance. Supplied with 20" extensions for faster installation. Made in the UK. Fits: Defender 90 all models 1984 -1998, Except NAS.

Rear Cross Member, Defender 90.....PLH61990HD \$ 489.00

Replacement Rear Cross Member Defender 110, 130 with 15" Extensions

Made with 3 mm thick steel for extra strength. Hot dipped galvanized for superior corrosion resistance. Supplied with 20" extensions for faster installation. Made in the UK. Fits: Defender 110 all models 1983 - 1998. PLH619110HD \$ 498.00

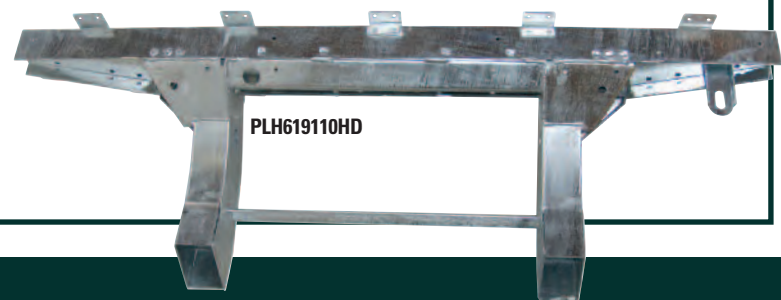

PLH619110HD

All our chassis are shipped via truck freight and are built to travel. You will be contacted with actual freight charges prior to shipping.



Defender 90 NAS Galvanized Chassis
Shown RNC878

Defender Galvanized Chassis

Defender 90 Chassis: Fits all body styles

NAS 90 V8 with NAS rear crossmember	RNC878	\$ 3350.00
NAS 90 V8 with Puma rear crossmember	RNS365	\$ 3359.00
90 300Tdi with NAS rear crossmember	RNS559	\$ 3359.00
90 300Tdi with Puma rear crossmember	RNS560	\$ 3359.00
90 200Tdi, 2.5 Turbo, 2.5 NA, and 2.5, 2.3 Petrol with Puma rear crossmember	RNS561	\$ 3359.00

Defender 110 Chassis: Fits all body styles

NAS 110 V8 with Puma rear crossmember for steel fuel tank	RNH710	\$ 3699.00
NAS 110 V8 with Puma rear crossmember for plastic fuel tank*	RNS562	\$ 3699.00
110 300Tdi with Puma rear crossmember for steel tank	RNH697	\$ 3699.00
110 300Tdi with Puma rear crossmember for plastic fuel tank*	RNS564	\$ 3629.00
110 200Tdi, 2.5 Turbo, 2.5 NA, and 2.5, 2.3 Petrol with Puma rear crossmember for steel tank	RNS563	\$ 3399.00
110 SW, Crossmember Rear Floor, Genuine	RNQ687	\$ 206.67

Defender 130 Chassis: Fits all body styles (not shown)

130 V8 with Puma rear crossmember for plastic fuel tank	RNS565	\$ 4399.00
130 300Tdi with Puma rear crossmember for plastic fuel tank	RNS566	\$ 4399.00
130 200Tdi, 2.5 Turbo, 2.5 NA, and 2.5, 2.3 Petrol with Puma rear crossmember for steel fuel tank	RNI867	\$ 4399.00

***Updated Genuine plastic fuel tank kit** (Includes; fuel tank, pump, sender unit, mounting bracket, rear sway bar and harness link).....**RNK4297** **\$ 1099.00**

We welcome special chassis orders, please give us a call.

Start your project off right with a new galvanized chassis from Rovers North.

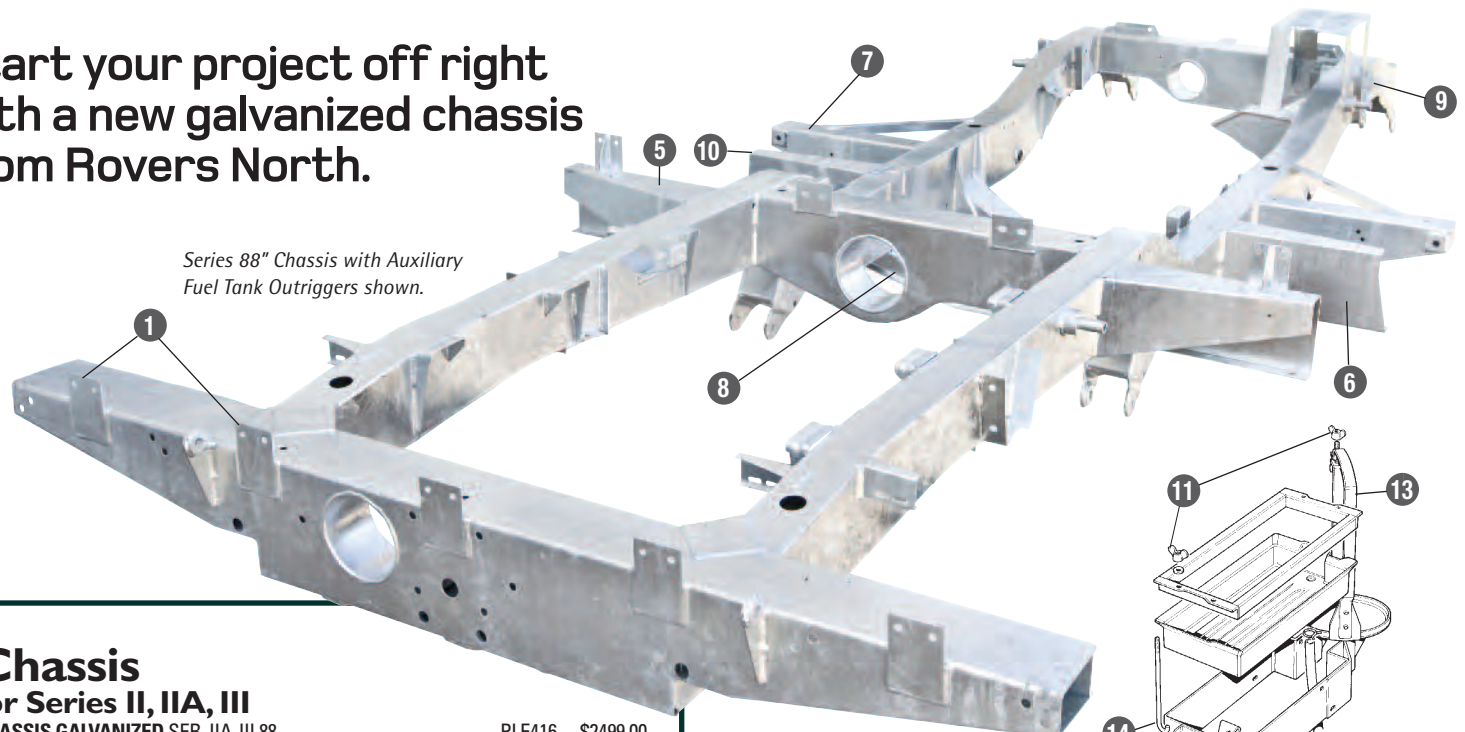

Series 88" Chassis with Auxiliary Fuel Tank Outriggers shown.

Chassis for Series II, IIA, III

CHASSIS GALVANIZED SER. IIA-III 88	PLE416	\$2499.00
CHASSIS GALVANIZED 109 SW SER.IIA 6CYL.....	PLQ322	\$3950.00
CHASSIS GALVANIZED 109 SW SER.III 6CYL.....	PLH416	\$3950.00
CHASSIS GALVANIZED SER.IIA-III 109 REG.....	PLE412	\$3684.00
CHASSIS GALVANIZED SER.IIA-III 109 SW	PLE413	\$3690.00
CHASSIS GALVANIZED 109" MILITARY	PLE414	\$4520.00
CHASSIS GALVANIZED SER.II 1959-1961 88.....	PLE4162	\$2599.00

Replacement Parts for Series Chassis

1. Rear Cross Member		
Civilian 88" w/18" extensions, w/spring perches, & bushings	RNE404	\$ 279.00
Civilian 109" w/6" extensions.....	NRC236-6S	239.00
Military 88" & 109" w/10" extensions, Galvanized.....	CHAS23	\$ 269.95
Military 88" Airportable (Lightweight) w/10" extensions.....	CHAS07	\$ 249.95
3. 109" LH Rear spring perch		
109" RH Rear spring perch	RNF382	\$ 86.92
109" RH Rear spring perch	RNF383	\$ 86.92
4. 109" Front of rear spring outrigger, left.....		
.....	RNF381	\$ 153.49
5. 88" Body Support Outrigger and Fuel Tank Mount, right.....		
88" Body Support and Fuel Tank Mount, left.....	CHAS03	\$ 98.85
109" Body Support & fuel tank mount, right.....	CHAS20	\$ 115.95
109" Body Support & fuel tank mount, left.....	CHAS21	\$ 115.95
6. 88" Fuel Tank Front Outrigger RH.....		
109 Fuel Tank Front Outrigger RH.....	CHAS19	\$ 69.00
7. 88" Bulkhead Outrigger.....		
109" Bulkhead Outrigger.....	RNF458	\$ 119.95
8. 88" Transmission Cross Member.....		
109" Transmission Cross Member.....	CHAS22	\$ 129.95



9. Front horn assembly, right Fits all civilian 88" & 109".....		
Front horn assembly, left Fits all civilian 88" & 109".....	CHAS12	\$ 159.00
Repair Kit for Front Horn Contains all the pieces to rebuild one frame horn (not assembled) Series IIA	CHAS13A	\$ 69.95
Series III	CHAS13B	\$ 69.95
10. Auxiliary Fuel Tank Outrigger.....		
.....	CHAS05	\$ 63.95

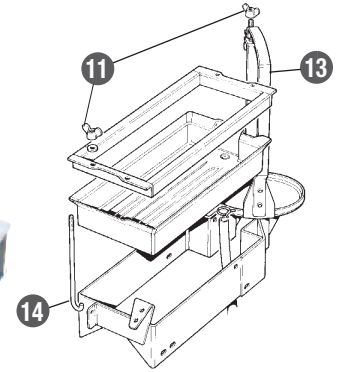

Battery Casing and Air Cleaner Support, Series II, IIA, III, 2.25 petrol

11. Wing Nut	RNB576	\$ 5.55
12. Stud for Wing Nut	RNA983	\$ POA
13. Hold Down Bracket for Battery, 2.25 litre	RNC506	\$ 21.95
14. J-Bolt Late Series IIA, III	PLC417	\$ 4.95

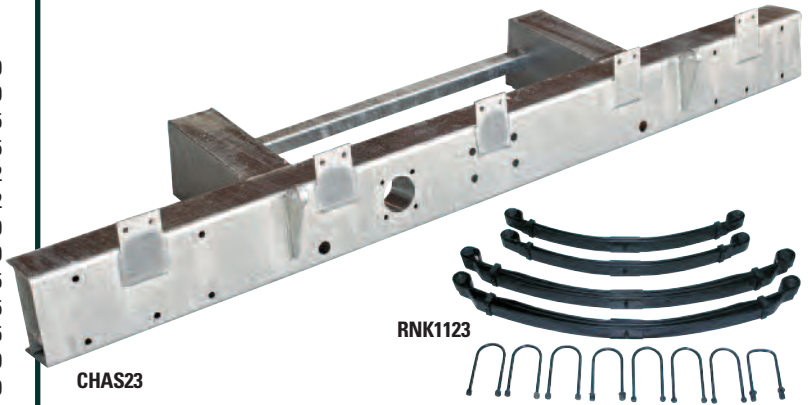

CHAS23

RNK1123

Series II, IIA, III Chassis Kits

SPRING & SHOCK KIT SWB SERIES IIA & III	PLK5123	\$ 599.00
SPRING & PROCOMP SHOCK KIT IIA & III SWB	PLK5223	\$ 699.00
PARABOLIC SPRING KIT w/OME SHOCKS 109"	RNK1123109	\$ 1189.00
PARABOLIC SPRING w/PRO COMP SHOCKS 109in	RNK1123109PC	\$ 879.00
PARABOLIC SPRING KIT w/OME SHOCK 88"	RNK112388	\$ 1159.00
PARABOLIC SPRING w/PRO COMP SHOCKS 88in	RNK112388PC	\$ 869.00
PARABOLIC SPRING SET OF 4-2/3LEAF 88+109	RNK1123	\$ 699.00
PARABOLIC SPRING SET OF 4-2/4LEAF 88+109	RNK1124	\$ 759.00
PRO COMP SHOCK SET OF 4 II-III 88 NITRO	PCS3088	\$ 199.00
PRO COMP SHOCK SET OF 4 II-III 109 NITRO	PCS3109	\$ 209.00
OME GAS SHOCKS SET OF 4 IIA & III 88"	OMESK88	\$ 499.95
OME GAS SHOCKS SET OF 4 IIA & III 109"	OMESK109	\$ 469.00
CHECK STRAP KIT 88"	RNK5141	\$ 99.50
CHECK STRAP KIT 109"	RNK5142	\$ 99.50
SPRING & SHOCK HARDWARE MOUNT KIT SER 88	RNK5143	\$ 204.24
SPRING & SHOCK HARDWARE MOUNT KIT SER 109	RNK5144	\$ 209.10
STEERING RELAY UNIT SERIES IIA & III	PLE493	\$ 89.90
MOTOR & TRANSMISSION MOUNT KIT SERIES	RNK5145	\$ 19.99
BRAKE PIPE KIT 88 SINGLE SYSTEM	RNK680	\$ 169.90



RNE404

BRAKE PIPE KIT 109" SINGLE SYSTEM.....	RNK681	\$ 184.50
BRAKE PIPE KIT 88" SER IIA DUAL POWER.....	RNK682	\$ 209.66
BRAKE PIPE KIT 88" SER III DUAL POWER.....	RNK683	\$ 229.95
EXHAUST KITS (pipes only)		
NRP STAINLESS EXHAUST 88" SERIES II-III.....	RNE0001AA	\$ 599.95
EXHAUST KIT 88" RH EXIT MUFFLER.....	RNK059	\$ 139.00
EXHAUST KIT 88" LH EXIT MUFFLER.....	RNK060	\$ 229.00
EXHAUST KIT 109" REG RH.....	RNK061	\$ 185.80
EXHAUST KIT 109" REG LH.....	RNK062	\$ 249.98
EXHAUST KIT 109" SW EARLY UP TO SUFF C.....	RNK063	\$ 179.99
EXHAUST KIT 109" SW LATE FROM SUFF C ON.....	RNK0631	\$ 139.00
EXHAUST KIT 109 ExMOD RH.....	RNK064	\$ 169.00
EXHAUST KIT 109 ExMOD LH.....	RNK065	\$ 259.00
HARDWARE KIT EXHAUST 88" & 109" REG.....	RNK050	\$ 24.39
EXHAUST HARDWARE KIT 109" SW.....	RNK058	\$ 99.98
CANISTER HANGER KIT 88 & 109 REG SERIES II-III		
FOR LH EXIT MUFFLER.....	RNK056	\$ 19.95
CANISTER HANGER KIT 109" SW.....	RNK0561	\$ 13.95
TAILPIPE HANGER KIT, 109" S.W. SERIES II-III.....	RNK055	\$ 28.95
TAILPIPE HANGER KIT RH EXIT 88" SER II-III.....	RNK052	\$ 29.95
TAILPIPE HANGER KIT LH EXIT 88" SER II - III.....	RNK053	\$ 38.95
TAILPIPE HANGER 109" REG SER II-III.....	RNK0531	\$ 69.43
INTERMEDIATE HANGER ASSY 88" SER II-III.....	RNK051	\$ 22.95
INTERMEDIATE HANGER ASSY 109" SW 4 CYL.....	RNK054	\$ 39.95
INTERMEDIATE HANGER ASSY 109" REG.....	RNK0541	\$ 71.75

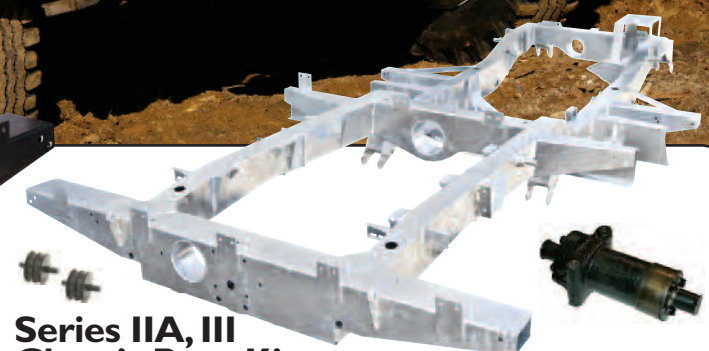

Series IIA, III Chassis Base Kits

88 BASE CHASSIS KIT RNK9991 Includes:

- 88 Galvanized Chassis
- Front & Rear Standard Duty OEM Leaf Springs with Mounting Hardware
- Front & Rear Shock Absorbers with Mounting Hardware
- Rear Check Strap Set
- Steering Relay Assembly
- Motor Mounts with Hardware
- Transmission Mounts with Hardware



BASE CHASSIS KIT SERIES 88.....RNK9991 \$ 3499.00



109 BASE CHASSIS KIT RNK9992 Includes:

- 109" Station Wagon 4 Cyl. Galvanized Chassis
- Front & Rear Standard Duty Parabolic Springs with Hardware
- Front & Rear Pro Comp ES9000 Gas Shocks with Hardware
- Rear Check Strap Set
- Steering Relay Assembly
- Motor Mounts with Hardware
- Transmission Mounts with Hardware



BASE CHASSIS KIT W/PARABOLICS SER 109 SW.....RNK9992 \$ 4595.00

Series II, IIA, III Galvanized Replacement Footwell, Seatbox and Body Panel Parts

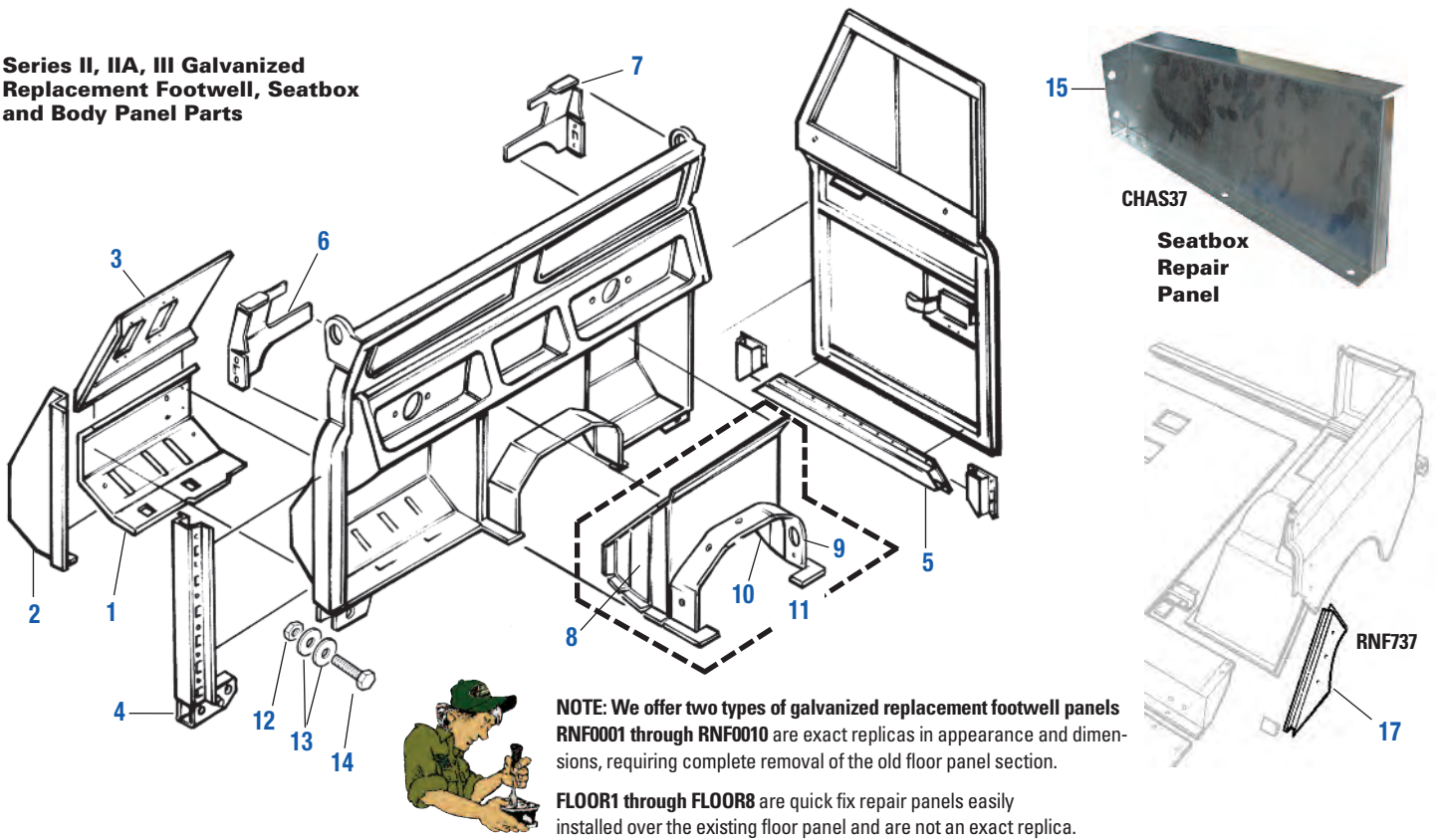

NOTE: We offer two types of galvanized replacement footwell panels RNF0001 through RNF0010 are exact replicas in appearance and dimensions, requiring complete removal of the old floor panel section.

FLOOR1 through FLOOR8 are quick fix repair panels easily installed over the existing floor panel and are not an exact replica.

18 ga. Galvanized Replacement Footwell Parts Series II, IIA, III 2.25 litre Bulkheads

- 1. Toe Board**, Replaces front angular floor section, galvanized.

Right Side as illustrated.....	RNF0003	\$ 59.95
Right Side Simplified quick repair version.....	FLOOR3	\$ 49.95
Left Side as illustrated.....	RNF0002	\$ 59.95
Left Side Simplified quick repair version.....	FLOOR2	\$ 49.95
- 2. Kick Panel** Triangular panel located on the inside of the door post. Has flanged corner to interconnect with replacement toe board to reconstruct a rusted through floor area. Galvanized.

Left Side complete panel.....	RNF0001	\$ 47.95
Left Side Simplified quick repair version.....	FLOOR1	\$ 47.95
Right Side complete panel.....	RNF0004	\$ 47.95
Right Side Simplified quick repair version.....	FLOOR4	\$ 47.95
- 3. Footwell Top**, Left Side.....FLOOR7* \$ 79.50
 Footwell Top, Right Side.....FLOOR8 \$ 49.38
- 3a. Footwell Replacement Assembly – Galvanized**
 Parts 1, 2 & 3 assembled as a unit. Replaces entire footwell, ribbed
 Driver's Side.....RNF0005* \$ 219.95
 Passenger's Side.....RNF0006 \$ 174.95

*The brake pedal cutout is for single system Master Cylinder. When installing later dual power Master Cylinder, the cutout will need to be lengthened.

4. Door Post Replacement

- Now supplied as 2-piece replacement. Extends further up the bulk head and includes hole for upper hinge, ensuring accurate hinge spacing.
- | | | |
|--|--------|-----------|
| RH Foot, painted..... | CHAS32 | \$ 42.50 |
| LH Foot, painted..... | CHAS33 | \$ 42.50 |
| One Piece LH as illustrated 18 3/4" tall, painted..... | CHAS17 | \$ 119.95 |
| One Piece RH as illustrated 18 3/4" tall, painted..... | CHAS18 | \$ 119.95 |

5. Door Rails – Galvanized

- | | | |
|--|--------|----------|
| Door Frame Repair Kit (replaces rusted bottom door frame)..... | CHAS24 | \$ 79.95 |
|--|--------|----------|

- | | | |
|---|---------|-----------|
| 6. Bulkhead Corner LH Repair Piece | CHAS36 | \$ 54.95 |
| 7. Bulkhead Corner RH Repair Piece | CHAS35 | \$ 54.95 |
| 8. Center Kick Panel LH | RNF0007 | \$ 68.90 |
| 9. Flange Only , for Gearbox Tunnel..... | RNF0008 | \$ 92.30 |
| 10. Center Kick Panel RH | RNF0009 | \$ 62.80 |
| 11. Center Bulkhead Assembly | RNF0010 | \$ 279.00 |
| 12. Nut | RNF459 | \$ 2.95 |
| 13. Washer | RNF460 | \$ 0.79 |
| 14. Bolt , Bulkhead to Outrigger..... | RNF461 | \$ 6.84 |
| 15. Repair Panel RH Seatbox Series II-III & Defender | CHAS37 | \$ 49.29 |
| 16. Repair Panel LH Seatbox Series II-III & Defender | CHAS38 | \$ 49.29 |
| 17. Panel RHR Extension, Defender 110, Genuine | RNH737 | \$ 79.95 |
| 18. Panel LHR Extension, Defender 110, Genuine | RNH738 | \$ 79.95 |

Defender 1983-2006 Replacement Floor Panels

Reproductions of exact factory units, these hand crafted 18 gauge steel units are galvanized* and ready to fit into your Defender for a proper restoration.

- | | | |
|---|---------|-----------|
| 1. Floor Panel , LHF Outer, galvanized..... | RNF0012 | \$ 69.95 |
| Floor Panel, LHF Inner, galvanized..... | RNF0014 | \$ 45.95 |
| Floor Panel, LHF Upper, galvanized..... | RNF0018 | \$ 89.95 |
| Floor Panel, RHF Inner, galvanized..... | RNF0015 | \$ 45.95 |
| Floor Panel, RHF Outer, galvanized..... | RNF0013 | \$ 69.95 |
| Floor Panel, RHF Upper, galvanized..... | RNF0019 | \$ 83.95 |
| 2. Kick Panel , LHF Outer, galvanized..... | RNF0016 | \$ 54.95 |
| Kick Panel, RHF Outer, galvanized..... | RNF0017 | \$ 54.95 |
| 3. Kick Panel , LHF Inner 90/110 NAS, painted steel..... | RNF0020 | \$ 119.95 |
| Kick Panel, RHF Inner 90/110 NAS, galvanized..... | RNF0021 | \$ 69.95 |

*All parts are galvanized except RNF0020 which is painted.

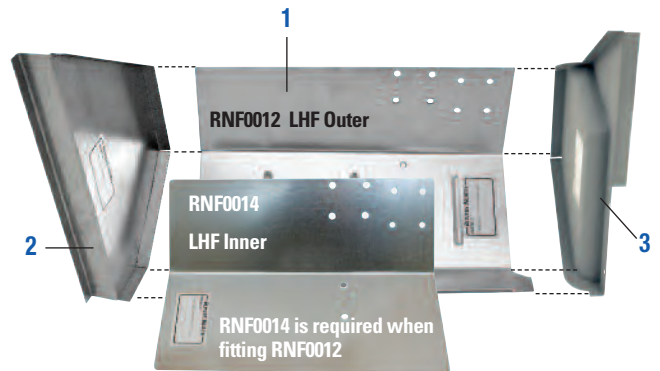

Go Pro!

Everything you need to perform a professional application of the world's best rust proofing.

Waxoyl Professional 2-Gun Starter Kit...WAX2 \$ 498.59

www.waxoyl-usa.com



Discovery Bonnet Blackout Kit

Essential for night time off-road driving safety, the Blackout Kit bonnet decal increases visibility by eliminating the glare from roof mounted driving lamps.

Discovery II Blackout Kit.....	PLH622	\$ 79.00
Discovery I Blackout Kit.....	PLH623	\$ 79.00
Land Rover Decal 16" x 8".....	RNF254	\$ 26.39



A. Land Rover Logo

Rigid, Standard.....	RNA3804	\$ 119.00
Rigid, Large.....	RNA3811	\$ 129.00
Soft, Standard.....	RNE387	\$ 69.50
Soft, Large.....	RNE386	\$ 69.50

B. DEFENDER logotype

Rigid, Standard.....	RNA3888	\$ 129.00
Soft, Large.....	RNTCDBL	\$ 69.50

C. Zebra Stripes

Rigid, Standard.....	RNA3886	\$ 119.00
Rigid, Large.....	RNA3887	\$ 129.00

D. Land Rover Rhino

Rigid, Standard.....	RNA3857	\$ 119.00
Rigid, Large.....	RNA3892	\$ 129.00
Soft, Standard.....	RNTCRAL	\$ 69.50
Soft, Large.....	RNTCRBL	\$ 69.50

E. Land Rover Lion Rigid

Rigid, Standard.....	RNA3820	\$ 119.00
Rigid, Large.....	RNA3834	\$ 129.00

F. Land Rover Elephant Soft

Soft, Standard.....	RNTCEAL	\$ 69.50
Soft, Large.....	RNTCEBL	\$ 69.50

G. Union Jack Cover Black/White/Pewter

Rigid, Standard.....	RNA3895	\$ 99.00
Rigid, Large.....	RNA3896	\$ 99.00

Union Jack Cover Red/White/Blue

Rigid, Standard.....	RNA3893	\$ 99.00
Rigid, Large.....	RNA3894	\$ 99.00

H. Keep Calm and Rover On

Rigid, Standard.....	RNTCKC	\$ 69.50
Rigid, Large.....	RNTCKCL	\$ 69.50

I. Land Rover Safari Tree

Rigid, Standard.....	RNA3885	\$ 119.00
Rigid, Large.....	RNA3869	\$ 129.00
Soft, Standard.....	RNTCSAL	\$ 69.50
Soft, Large.....	RNTCSBL	\$ 69.50



Soft Style

A

B

C



Rigid Style

D

E

F

G

H

I

Tire Covers Rigid or Soft

Standard fits tire sizes 205/80x16", 235/70x16", 255/75x16" and 255/55x18".
Large fits tire sizes 245/75x16", 7.50x16", 235/85x16" and 265/75x16".



TF104

Dakar Alloy Wheel

16" x 7", 33mm offset.

Fits: Defender, Discovery I, Range Rover Classic

Black.....TF105 \$ 299.00 ea
Silver.....TF104 \$ 299.00 ea



PLW216

Vented Road Steel Wheel, Black

16" x 6.5", 2-3/4" offset.

Fits: Defender, Discovery I, Range Rover Classic

Genuine..RNW216 \$ 147.50 ea
ProLine..PLW216 \$ 99.50 ea



PLW216W

Vented Road Steel Wheel, White

16" x 6.5", 2-3/4" offset.

Fits: Defender, Discovery I, Range Rover Classic

Genuine..RNW216 \$ 147.50 ea
ProLine White
PLW216W \$ 109.50 ea



RNA5003

Modular Style Heavy Duty Steel Wheel

16" x 7", finished in black, fits

16" tubeless tires up to 285/75.

Fits: Defender, Discovery I, Range Rover Classic

RNA5003 \$ 89.99



PLC880

Series Land Rover Road Wheel

16" x 5.5" 1-7/8" offset, black.

Fits: Series II, IIA, III

Genuine RNC880 \$ 169.95 ea
ProLine PLC880 \$ 98.95 ea



RNX021

PLX021

PLE186

Hub Caps for Steel Wheels

Defender, Discovery I

Genuine.....RNX021 \$ 4.95

ProLine.....PLX021 \$ 1.95

Defender, Genuine RNE186 \$ 8.95

Defender, ProLine..PLE186 \$ 2.95



PLW216W shown in Alpine white



RNW221



RNS066

Lug Nuts For Steel Wheels

Series III, Defender, Discovery I, RRClassic, Genuine, eaRNS066 \$ 4.49

Series III, Defender, Discovery I, RRClassic, ProLine, ea.....PLS066 \$ 1.31

Locking Wheel Nuts, Steel Wheels, Genuine.....RNW221 \$ 195.22

Discovery II, RRP38A Steel wheel nut, Genuine.....RNQ821 \$ 6.99

Discovery II, RRP38A Steel wheel nut, ProLine.....PLQ821 \$ 2.99

Lug Nuts For Alloy Wheels

Series III, Defender, Discovery I, RRClassic Stainless, Genuine.....RNX043 \$ 19.95

Series III, Defender, Discovery I, RRClassic Stainless, ProLine.....PLX043 \$ 9.50

Locking Wheel Nuts, Alloy Wheels, Genuine.....RNW219 \$ 201.28

Cover, Locking Wheel Nuts, Genuine.....RND706 \$ 4.99

Discovery II, RRP38A Stainless capped wheel nut, Genuine.....RNH565 \$ 13.95

Discovery II, RRP38A Stainless capped wheel nut, ProLine.....PLH565 \$ 5.95

LR4 Lug Nut Alloy Wheel 2008 on, Genuine.....RNQ526 \$ 12.98

LR4 Lug Nut Alloy Wheel 2008 on, ProLine.....PLQ526 \$ 7.95



4 RND705



5



6



7



8



9



10

Genuine Land Rover Hub Caps

- | | | |
|---|--------|----------|
| 4. Cap Wheel Center Discovery II | RND705 | \$ 59.95 |
| 5. Centre Cap, Alloy Wheel Bright Black | RNQ170 | \$ 24.95 |
| 6. Cap Wheel Center Jeweled for 18" Wheel Discovery II, Range Rover P38A, LR2, LR3, L320 & L322 | RNH669 | \$ 11.95 |
| 7. Cap, Wheel Center Pewter Discovery I & Tomb Raider Edition Defender..... | RNH675 | \$ 10.95 |
| 8. Cap, Wheel Center Quick Silver Range Rover Classic, Discovery I & Defender | RNH673 | \$ 10.95 |
| 9. Cap, Wheel Center Silver Sparkle Defender & Discovery I..... | RNC875 | \$ 13.95 |
| 10. Cap Wheel Center Polished Green/Silver..... | RNS865 | \$ 26.55 |
| 11. Wheel Center Cap Range Rover Classic | RND702 | \$ 14.50 |



RVS Beadlock Alloy Wheels
Includes wheel nut set. 16" x 7", 35mm offset, bead lock ready.
Fits: Discovery II, Range Rover P38A
Black TF106 \$ 269.00 ea
Anthracite TF107 \$ 269.00 ea



Bead Lock Kit for RVS Alloy Wheel
Fits RVS wheels; TF106, TF107, RNA100A, RNA100B
Bead Lock Kit Set of 4, anthracite RNA100L \$ 689.00
Bead Lock Ring Single, anthracite RNA101L \$ 188.00



RNA5004

Vented Heavy Duty Steel Wheel
16" x 8", finished in satin black, fits 16" tubless tires up to 285/75. Includes 5 steel lug nuts. Fits: Discovery II, Range Rover P38A BlackRNA5004 \$ 98.00 ea



4



1



11



Sonax Wheel Cleaner Plus
500ml SWCP500 \$ 19.99



2



3

Defender Wheels

- | | | |
|--|----------|------------|
| 1. Sawtooth 5-Spoke Alloy, 7Jx16, Set of 4 (includes center caps)..... | PLS842-4 | \$ 1129.00 |
| Sawtooth 5-Spoke Alloy, 7Jx16, Set of 5 (includes center caps)..... | PLS842-5 | \$ 1399.00 |
| Sawtooth 5-Spoke Alloy, 7Jx16 each, ProLine | PLS842 | \$ 289.00 |
| Centre Cap, Black & Silver Logo, Genuine | RNS843 | \$ 18.69 |
| 2. Boost 5-Spoke Alloy, 7Jx16, Set of 4 (includes center caps) | RNS862-4 | \$ 1498.00 |
| Boost, 5-Spoke Alloy, 7Jx16, Set of 5 (includes center caps) | RNS862-5 | \$ 1890.00 |
| Centre Cap, Silver Logo | RNC875 | \$ 13.95 |
| 3. Dual Finish Five-Spoke Alloy, 7Jx16, Set of 4 (does not include center caps)..... | RNS863-4 | \$ 1989.00 |
| Dual Finish Five-Spoke Alloy, 7Jx16, Set of 5 (does not include center caps)..... | RNS863-5 | \$ 2479.00 |
| Centre Cap, Green & Gold Logo | RNS864 | \$ 26.55 |
| Centre Cap, Green & Silver Logo | RNS865 | \$ 26.55 |
| 4. Tornado Road Wheel Sparkle Silver..... | RNW211 | \$ 461.94 |



Kahn Designs' elegant sculpted alloy wheels evolved through artistic innovation and state-of-the-art manufacturing and materials technology. With expertise based on 20 years of pursuing perfection, these 16" and 18" are the finest wheels we have ever offered.



COS18713

New



RNH669

COS16711



COS16713

New

Kahn 16x8" Defend 1948

16" x 8", finished in silver, matte black and piano black with diamond cut finish, 265/75/R16 tires, direct fit original nuts. **Fits: Defender**

16" Silver.....COS16711 \$ 479.00

16" Diamond CutCOS16713 \$ 519.00

16" Matt Black.....COS16712 \$ 479.00

LR Hubcaps

Bright BlackRNQ170 \$ 24.95

JeweledRNH669 \$ 11.95



COS18712

Kahn 18x8" Defend 1983

18" x 8", finished in silver, matt black and piano black with diamond cut finish, 265/65R18 Tires, direct fit original nuts. **Fits: Defender**

18" Silver.....COS18711 \$ 549.00

18" Diamond Cut.....COS18713 \$ 599.00

18" Matt Black.....COS18712 \$ 549.00

LR Hubcaps

Bright BlackRNQ170 \$ 24.95

Jeweled.....RNH669 \$ 11.95



COS20711

New



RNQ170

Kahn 20x9" Mondial

20" x 9", finished in volcanic black and piano black with diamond cut finish, direct fit original nuts.

Fits: Defender 2003 on

20" Diamond Cut.....COS20711 \$ 639.00

20" Volcanic Black.COS20712 \$ 639.00

LR Hubcaps

Bright BlackRNQ170 \$ 24.95

Jeweled.....RNH669 \$ 11.95

COS20712

New

From Kahn Design X-Lander Grille with Headlamp Surrounds

Made of high quality ABS material and comes ready to prime and paint. Suitable for both

Defender 90 & 110 models.

X-Lander Grille

w/Headlight Surrounds

KXL1001 \$ 899.00



KXL1001

Shown below—Kahn Defender Concept 17 wide body by A. Kahn Design with Defend 1983 18" wheels, Defender 90 Wide Track Arch Kit, Defender Military Front Grille, Defender Side Vents and Arch Kit Mesh Inserts.

Please inquire for other Kahn Defender products.

Kahn Military Grille w/Mesh (shown below)
KFR1002 \$ 559.00



KFR1002

A Series, Defender Side, Rear Steps

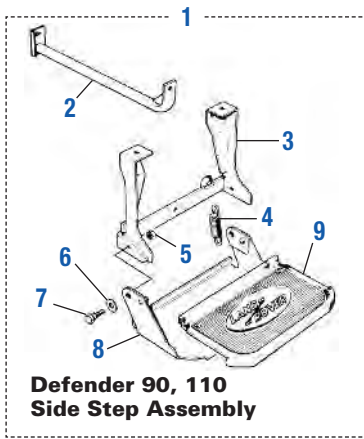

Defender 90, 110 Side Step Assembly



Defender 90, 110 Rear Step Assembly

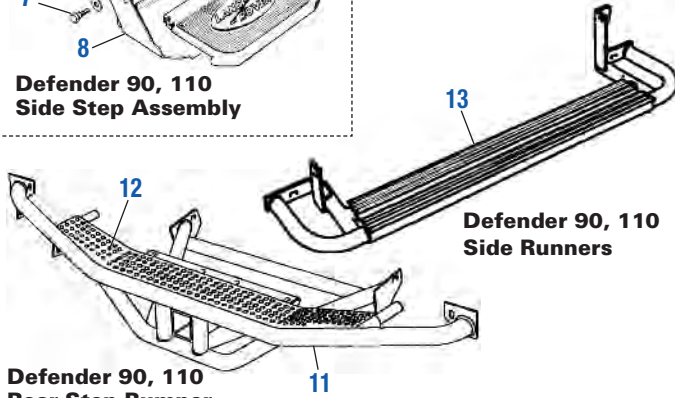

Defender 90, 110 Side Runners

Defender 90, 110 Rear Step Bumper



Series II, IIA, III Side Step Side Folding Step Kit
Fits all 88 and 109 Series II-III models, ProLine
PLC768 \$ 98.84
Replacement rubber pad
RNC222 \$ 37.00



Defender Side Runners

Defender 90 Tubular Side Step, Pair, Black, Genuine	RNB066	\$ 679.00
Defender 90 Tubular Side Step Pair, Black, ProLine.....	PLB066	\$ 349.95
Defender 110 Station Wagon, Side Step, Pair Black.....	RNB069	\$ 798.95



Defender Folding Steps

Side Folding Step Kit, Defender, Genuine	RNF367	\$ 189.95
Side Folding Step Kit, Defender, ProLine.....	PLF367	\$ 79.95
Side Folding Step Defender 2007+, Genuine	RNJ846	\$ 232.18
Rear Folding Step Kit, Defender, Genuine	RNF368	\$ 189.95
Rear Folding Step Kit, Defender, ProLine.....	PLF368	\$ 79.95
Replacement Rubber Pad For Side Step ('07+ as well), Genuine	RNE300	\$ 39.95
Rubber Mat For Rear Folding Step, Defender, Genuine	RNE302	\$ 46.23

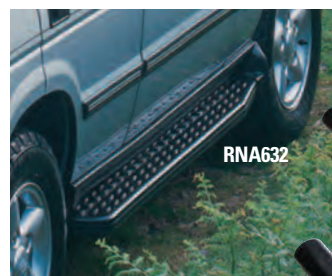

Genuine Land Rover Side Steps

Discovery I, Side Steps, Genuine	RNA632	\$ 759.97
Rear Folding Step, Discovery I & II, Genuine	RNH239	\$ 269.95
Rear Folding Step, Discovery II		
from VIN 1A298104, Genuine	RNS807	\$ 245.81
MAT REAR BUMPER STEP DISCOVERY II	RNS809	\$ 40.03
SIDE STEP PAIR BLACK DEFENDER 90 2007 ON	RNQ674	\$ 899.95
SERVICE REAR STEP DISCOVERY	RNQ685	\$ 179.95



A SERIES, DEFENDER SIDE, REAR STEPS

1. FOLDING SIDE STEP KIT DEFENDER, GENUINE	RNF367	\$ 189.95
FOLDING SIDE STEP KIT DEFENDER, PROLINE.....	PLF367	\$ 79.95
SIDE FOLDING STEP DEFENDER 2007+	RNJ846	\$ 232.18
FOLDING SIDE STEP DEFENDER NEW STYLE	RNS588	\$ 299.95
2. BRACKET SIDE STEP SUPPORT DEFENDER	RNE379	\$ 29.66
3. BRACKET - SIDE STEP MOUNT DEFENDER 90/110	RNE344	\$ POA
4. SPRING - SIDE STEP - 90/110	RNE294	\$ 11.95
5. FLANGE NUT M8	RNH087	\$ 1.04
6. WASHER	RNF419	\$ 0.81
7. PIVOT BOLT - SIDE STEP DEFENDER 90/110	RNE343	\$ POA
8. MAT SIDE STEP DEFENDER	RNE300	\$ 39.95
9. FOLDING STEP REAR DEFENDER, GENUINE	RNF368	\$ 189.95
FOLDING STEP REAR DEFENDER, PROLINE.....	PLF368	\$ 79.95
10. RUBBER MAT REAR FOLDING STEP DEFENDER	RNE302	\$ 46.23
11. REAR STEP BUMPER DEFENDER 90	RNQ641	\$ 808.23
REAR STEP BUMPER DEFENDER 110	RNQ642	\$ 808.23
12. RUBBER MAT REAR STEP BUMPER	RNQ165	\$ 155.36
13. GENUINE SIDE RUNNER SET DEFENDER 90 BLACK	RNB066	\$ 679.00
PROLINE SIDE RUNNER SET DEFENDER 90 BLACK.....	PLB066	\$ 349.95
SIDE RUNNER TUBULAR SIDESTEP PAIR BLACK - DEFENDER 110 SW.....	RNB069	\$ 798.95
SIDE STEP PAIR BLACK DEFENDER 90 2007 ON STYLE.....	RNQ674	\$ 899.95

ROCK SLIDERS

TF ROCK SLIDER SET WITH TREE GUARD DEFENDER 90		
BLACK POWDER COATED FINISH.....	TF801	\$ 429.00
ROCK SLIDER SET W/TREE GUARD 110 BLK PR.....	TF810	\$ 479.00

Interior - Series II, IIA, III & Defender Seat Belt Kits

Static Shoulder Harness

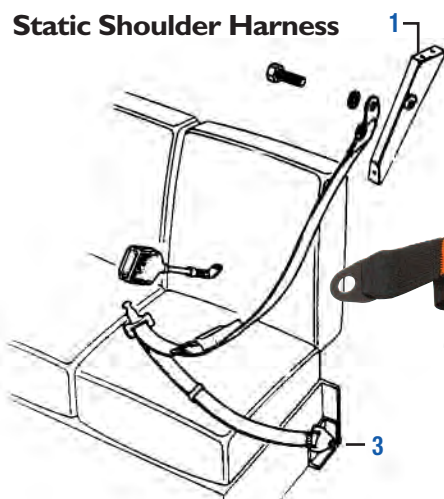

Static Shoulder Harness Kit

3 Point Series IIA & III, RH or LH PLF353 \$ 61.95



Upper Defender Seat belt Bracket for Hard Tops

Upper RH RNC112 \$ 8.41
Upper LH RNC113 \$ 8.54

Inertia Shoulder Harness

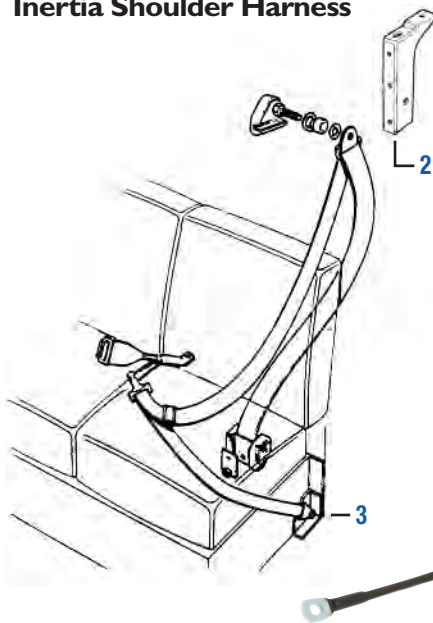

Genuine Inertia Shoulder Harness Kit

Includes bottom mounting bracket.

RH front, Defender RNI873 \$ 200.16
LH front, Defender RNI874 \$ 200.16

Inertia Shoulder Harness Kit

Series & Defender
LH or RH reel,
buckle & hardware.
PLF370 \$ 79.95



Upper Series Seatbelt Bracket for Hard Tops

Upper RH PLB963 \$ 49.99
Upper LH PLB964 \$ 49.99

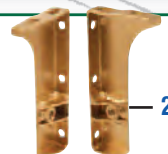

Bottom Series & Defender Seat Belt Bracket

Bottom RH RNB898 \$ 34.50
Bottom LH RNB899 \$ 34.50



New
RSB001

Front Seat Belt Assembly 3-point Inertia Shoulder Harness, 4 Door & 88

Front LH (driver side) outer seat position in 88 & 4 door Series II-III, Defender 110 and 130 models RSB001 \$ 139.00

Front RH (passenger side) outer seat position in 88 & 4 door Series II-III, Defender 110 and 130 models. RSB002 \$ 139.00

Middle Row Seat Belts

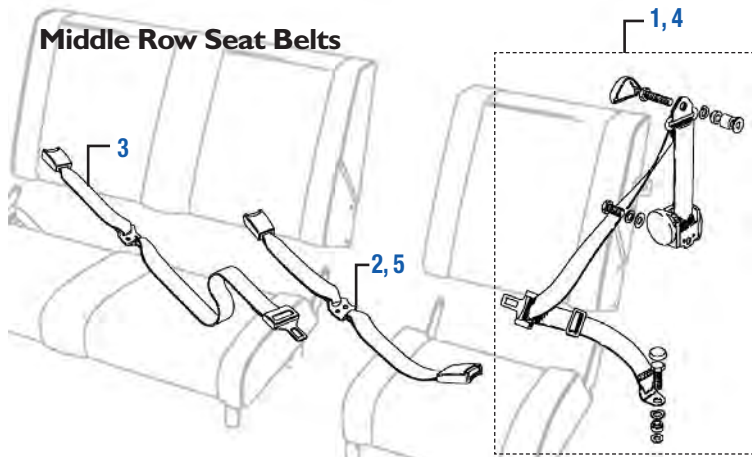

Middle Row Seat Belt Set 109, 110 Station Wagons

1. Reel Assembly w/hardware & instructions, RH & LH, Genuine..RNN250 \$ 229.95
NEW Seat Belt, 3-Point Inertia Shoulder Harness.....RSB007 \$ 119.00
2. Middle Lap Double Buckle Assembly, Genuine.....RNN251 \$ 99.80
NEW Rear Floor Mounted Double Buckle Assembly.....RSB005 \$ 67.39
3. Middle Lap Tongue, Buckle Assembly, Genuine.....RNN252 \$ 169.95
NEW Middle Lap Tongue, Buckle Assembly.....RSB006 \$ 69.99

Forward Facing Optional Rear Seat Belts, NAS 90 Soft Top

4. Reel Assembly w/hardware & instructions, RH & LH, Genuine..RNN862 \$ 259.95
NEW Seat Belt, 3-Point Inertia Shoulder Harness.....RSB007 \$ 119.00
5. Rear Floor Mounted Double Buckle Assembly, Genuine.....RNN863 \$ 294.18
NEW Rear Floor Mounted Double Buckle Assembly.....RSB005 \$ 67.39
6. Seat Belt Assembly Individual Rear Lap Type Defender.....RNO620 \$ 98.50
(See page 49)

Static & Inertia Lap Belts

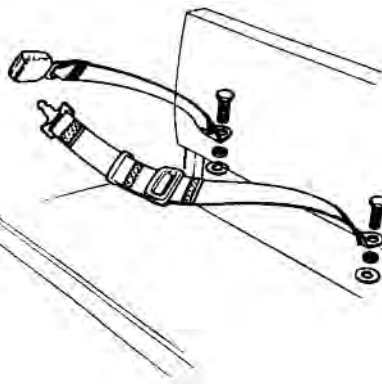

PLF234

Static Lap Belt

Series & Defender PLF234 \$ 44.39
Genuine (not shown) RNF234 \$ 148.99



Inertia Retractable Lap Belt

Series & Defender PLF234R \$ 52.45

Rear Jump Seat Lap Belts



New

1. RNO620



Rear Inner Facing Jump Seat Belts

1. Seat Belt Assembly, Rear Lap Set of Two, Defender Style RNO620 \$ 98.50

NEW Rovers North Seat Belts

USDOT FMVSS 209/302 Tested and approved seat belt assemblies for Land Rover Series and Defender vehicles. Compatible with seatbelt electronic warning system. Made in the UK.

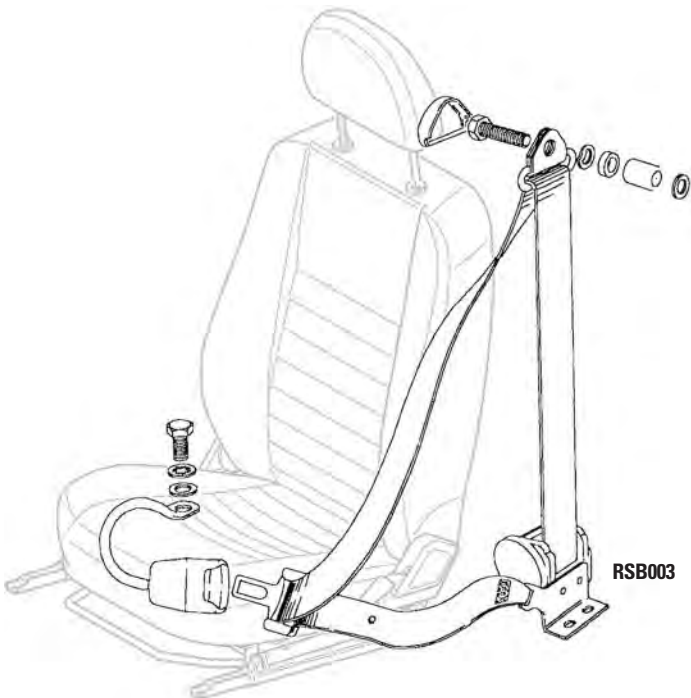

RSB003



NEW 2 Door version with integral base unit

RSB004

Seat Belt Assembly 3-point Inertia Shoulder Harness, 2 Door

Front LH (driver side) outer seat position in 2 door 109 Series II-III, Defender 90, 110, 130RSB003 \$ 149.00
Front RH (passenger side) outer seat position in 2 door 109 Series II-III, Defender 90, 110, 130RSB004 \$ 149.00

New

3. Middle Row Seat Belt 109, 110 Station Wagons



RSB006

New

2, 5. Middle Row Seat Belt 109, 110 Station Wagons, NAS D90 Soft Top



RSB005

New

1, 4. Middle Row Seat Belt 109, 110, 130 SW, Crew Cab



RSB007

1. Middle Row Seat Belt 109, 110 Station Wagons



RNN250



RBL1727SSS



Safety Devices®

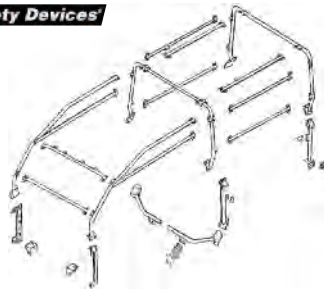

ROLL CAGE FULL EXTERNAL DEFENDER 90 HARDTOP

6 point full external bolt-in roll cage for vehicles with bulkhead. Please note that models between 1983-1988 had three raised ribs on the roof approx. 22mm (7/8") tall. This kind of roof does not work with our external roll cages as the hoops will clash with them. Finished roll cage provided with black powdercoat paint finish unless specified otherwise. Other colours available: grey, blue, silver, white and red. Roll cage can be provided unpainted by special request (no reduction in price). Made in the UK by Safety Devices. **RBL1087SSS \$2950.00**



Safety Devices®

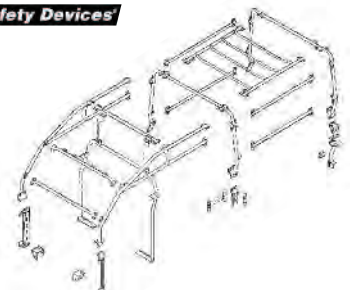

ROLL CAGE FULL DEFENDER 110 NAS SAFARI

8 point multi-point bolt-in full external/internal roll cage. Mounts to the chassis at 6 external points. Please note that models between 1983-1988 had three raised ribs on the roof approx 22mm (7/8") tall. This kind of roof does not work with our external roll cages as the hoops will clash with them, nor will it fit if the rear seat box is stepped in the rear corner. Finished roll cage provided with black powdercoat paint finish unless specified otherwise. Other colours available: grey, blue, silver, white and red. There is a surcharge for colours other than black. Roll cage can be provided unpainted by special request (no reduction in price). Total weight of roll cage including fitting kit: 124.5kgs. Installation time: approx 20 hours. (2 people, 1 day). Roll Cage by Safety Devices. Fits: Defender 110 Station Wagon 4-door (1983-present) **RBL1727SSS \$3499.00**



Safety Devices®

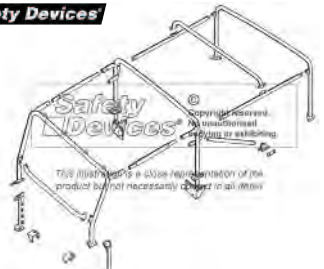

ROLL CAGE FULL EXTERNAL DEFENDER 90 SOFT TOP

8 point multi-point external/internal bolt-in roll cage. Utilises existing hood which will need modification. Front legs are NAS style. Finished roll cage provided with black powdercoat paint finish unless specified otherwise. Other colours available: grey, silver, white and red. Roll cage can be provided unpainted by special request (no reduction in price). Roll Cage by Safety Devices. Fits: Defender 90 Soft Top 2-door (1983-present) **RBL1887SSS \$2895.95**



Safety Devices®

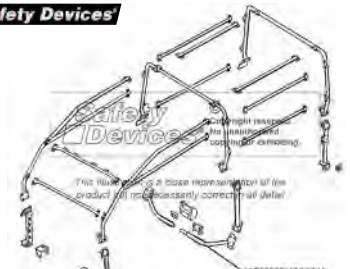

ROLL CAGE FULL EXTERNAL DEFENDER 110 2 DOOR

Full external multi-point bolt-in roll cage. Made to NAS Specification. Finished roll cage provided with black powdercoat paint finish unless specified otherwise. Other colours available: grey, charcoal grey, silver, white and red. Roll cage can be provided unpainted by special request. Roll Cage by Safety Devices. Fits: Defender 110 Hard Top 2-door (1983-present) **RBL1907SSS \$3199.95**

LAND ROVER DEFENDER DISCOVERY LR3 & LR4

SMART GEAR FOR THE WORLD'S TOUGHEST ADVENTURES



GENERAL Accessories

ROOF RACK ACCESSORIES

WOLF PACK STORAGE CONTAINERS	SBOX008	\$ 39.95
DOUBLE 20 LITRE FUEL CAN HOLDER - BLACK	JCH004	\$ 109.00
SINGLE JERRY CAN HOLDER	JCH009	\$ 79.95
WATER TANK LOCKING TAP	WTAN016	\$ 21.95
PREMIUM WATER TANK HOSE KIT	WTAN029	\$ 29.95
HI-LIFT JACK MOUNT BRACKET	JADA007	\$ 47.95
45L WATER TANK WITH MOUNT	WTAN030	\$ 179.00
RATCHETING SPADE/SHOVEL MOUNT BRACKET	RRAC024	\$ 47.95
UNIVERSAL CORNER BRACKETS.....	RRAC030	\$ 69.95
STAINLESS STEEL TIE DOWN RINGS	RRAC025	\$ 9.95
ROOF RACK SKI/SNOWBOARD	RRAC003	\$ 135.00
VEHICLE LADDER - 2 PIECE / LAND ROVER DEFENDER 90 & 110	LALD001	\$ 149.00
STRATCHITS (PAIR).....	STRA034	\$ 29.95
LIGHTING, CAMPING GEAR		
STAINLESS SIDE MOUNT TABLE, DEFENDER	TBRA008	\$ 223.00
SIDE TABLE MOUNTING KIT, DEFENDER	TBRA002	\$ 21.95
40"/1016mm LED FLOOD/SPOT	RRAC046	\$ 695.00
UNIVERSAL ROOF RACK SPOTLIGHT	RRAC022	\$ 29.95
SPARE TIRE MOUNT BBQ (ADJUSTS TO YOUR SPARE WHEEL)	VACC023	\$ 125.00

DEFENDER Accessories

ROOF RACKS

SLIMLINE II FULL RACK - TALL / LAND ROVER DEFENDER 90	KRLD007T	\$ 1080.00
SLIMLINE II FULL RACK - TALL / LAND ROVER DEFENDER 110	KRLD003T	\$ 1399.00
SLIMLINE II FULL RACK D110	KRLD03T	\$ 1399.00
SLIMLINE II HALF RACK D110	KRLD005T	\$ 933.00
SLIMLINE II FULL RACK - D90	KRLD07T	\$ 1080.00
1400MM LOAD BARS - DEFENDER	KRLD008	\$ 293.00

LR3 / LR4 Accessories

STORAGE SYSTEMS / WATER SOLUTIONS

FRONT RUNNER DRAWERS, LR3 & LR4	SDDR002	\$ 1592.00
WOLF PACK STORAGE CONTAINERS (for SDDR002)	SBOX008	\$ 39.95
ROOF RACKS		
SLIMLINE II FULL RACK - FOOT RAIL, LR3 & LR4	KRLD022T	\$ 1087.00
SLIMLINE II HALF RACK - FOOT RAIL, LR3 & LR4	KRLD023T	\$ 788.00



FRONT RUNNER | GET AHEAD OF THE PACK

Africa proven gear for your vehicle.

www.roversnorth.com



FRONT RUNNER
VEHICLE OUTFITTERS



Product Information

EXT371-BV

Standard Front Seats in Black Vinyl

Exmoor Trim produce a range of Series II-III seating that is simply as good as it gets. The front seat cushions and squabs use modern high quality foam, have superb feel and ride. Fitted with the metal back plates beautifully reproduced as original and not with a substandard wooden frame—an important safety factor. The Standard, Elephant Hide and Deluxe seat backs are supplied with new pivot bolts, nylon washers and locking bolts, if you require leather retaining straps then these are available separately. Seat belts not included, see page 48.

Seat Cushion Set in Black Vinyl

Front Set of 6 Cushions.....EXT371-BV	\$ 429.00	Centre Bottom.....EXT377-BV	\$ 47.00
Individual Seat Cushions in Black Vinyl			
Outer Bottom Non-Adj.....EXT374-BV	\$ 68.00	Outer Back w/Fixing Bolts.....EXT372-BV	\$ 90.36
Outer Bottom for Adj. Tray...EXT375-BV	\$ 69.00	Outer Back w/Fixing Pins.....EXT373-BV	\$ 90.36

Trim and Fabric Choices

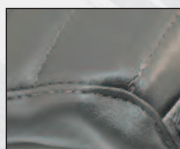

Dark Grey Vinyl



Mondus 2007



Caviar



Techno Cloth

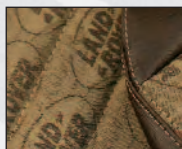

Logo Tan

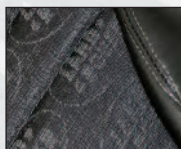

Logo Black

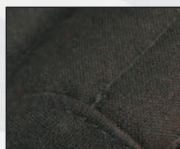

Outlast Black Canvas



Elephant Hide

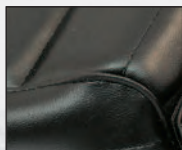

Black Vinyl



Twill Vinyl



Car Demin Vinyl

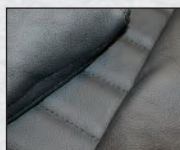

Black Leather



Grey Leather



XS 1/2 Leather



G4 Dimple



Diamond XS Black



Diamond XS Red

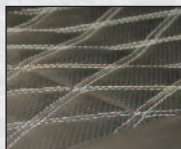

Diamond XS White

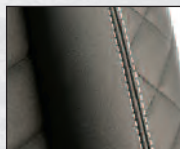

Diamond XS



Product Information

EXT371-EHG

Standard Front Seats in Elephant Hide Grey Vinyl

seating was introduced into mainstream Land Rover production in 1954, and used to great effect in the Series II and IIA interiors.

At the time there were on average 1700 Land Rovers rolling off the production line a week. Taking in to account model variations and seating types, the result was over 1000 seats a day going through the exceptionally busy trim shop. We now have a material that's a superb reproduction and gives all of the features that are so important if restoring these historic vehicles. Now manufactured with modern quality vinyls that give the same effect and long life as this classic material has done for over 40 years. Seat belts not included.

Seat Cushion Set in Elephant Hide Grey Vinyl

Front Set of 6 Cushions.....EXT371-EHG	\$ 637.22	Centre Bottom.....EXT377-EHG	\$ 93.50
Individual Seat Cushions in Elephant Hide Vinyl			
Outer Bottom Non-Adj.....EXT374-EHG	\$ 89.50	Outer Back with Fixing Bolts.....EXT372-EHG	\$ 139.00
Outer Bottom for Adj. Tray...EXT375-EHG	\$ 99.79	Outer Back with Fixing Pins.....EXT373-EHG	\$ 139.00

Product Information



Deluxe Front Seats in Black Vinyl

This style of deluxe front seats was used throughout the production run of the Series III Land Rover with its distinctive sculptured design and face fluting running from front to back in the centre panels of the seats. The centre seat back mounts with pin type fittings and the outer seat backs mount with fixing bolts that use internal threads for securing upright into adjustable trays.

Seat Cushion Set in Deluxe Black Vinyl

Front Set of 6 Cushions.....EXT378-1	\$ 459.00	Centre Bottom.....EXT378-5	\$ 62.50
Individual Deluxe Seat Cushions in Black Vinyl			
Outer Bottom for Adj. Tray...EXT378-3	\$ 78.50	Outer Back w/Fixing Bolts.....EXT378-2	\$ 89.75
		Centre Back w/Fixing Pins.....EXT378-4	\$ 77.07

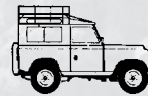

EXT370-BV

NEW

Product Information

Extreme MKII Hi-Back Front Seat Assembly

The all new Mk II Hi-Back Extreme offers Series owners the latest in front seat safety and comfort. Features include internal steel frame, enhanced side bolsters, twin stalk adjustable head rest and a large rear storage pocket. Available with optional heat and lumbar for enhanced comfort. Will fit fixed, or adjustable seat bases. Made to special order in the UK. **FITS:** Series II, IIA, III 88 & 109 front outer seat position, all models except Air Portable "Light-weight" 88.



NEW Extreme MKII Hi-Back Front Seat Assembly

Includes one base and matching back

Black Vinyl.....EXT370-BV	\$ 392.75
Dark Grey Vinyl.....EXT370-DGV	\$ 392.75
Caviar.....EXT370-CA	\$ 405.50

Techno.....EXT370-TC	\$ 428.67
Logo Tan.....EXT370-LRB	\$ 428.67
Black Leather.....EXT370-BL	\$ 614.04
Logo Black.....EXT370-LRBK	\$ 428.67



EXT009-11

Elephant Hide Grey vinyl seat set EXT371-EHG installed with Moulded Matting System EXT009-11.



EXT009-11

Series II-III Moulded Matting System

One-piece insulated rubber for superior sound proofing and wear durability. Approved by Land Rover. "This is the Kit." **EXT009-11 \$ 799.00**

Series IIA-III Trim Kit, Footwell Area

Identical to original LHD Series 1959 -1984 trim. Kits include lower dash trim, kick panel top and outer side trim, tunnel cover trim and seat box trim. Available in Black Hardura coated felt with bound edges. Hard wearing and easy to clean. Fits: Series IIA-III, 4cyl, LHD. Will require some trimming when fitted to early Series II-IIA positive earth models, and RHD models. Will not fit 88 Air Portable, V8 109, and 6 cylinder 109 models.



RNI0001

RNC128

ProLine Trim Kit with original felt backing.....RNI0001	\$ 239.00
Tunnel Cover only, original felt backing.....RNC128	\$ 89.90



Seat Heater Kits for two seats.

Goes great with our retrim kits or added to your existing front or rear seats. Sold in pairs. Includes wiring loom & Hi / Low Switches and instructions.

WAECO Seat Heater Kits

Easy to install DIY kit, fits into all types of Land Rover Seats. EXT010-2 \$ 139.00
 Custom installed when ordering a new seat pair. EXT010-2IN \$ 198.00

EXT010-2

Get Heated this Winter!

Enjoy a nice warm bum this winter with our WAECO "Einbau-Sitzheizung" (Set Heater Insert) for your Series II-IIIA seats. Combine with a lumbar kit for the ultimate back and driving comfort. Now available in the new Extreme MKII Hi-Back Front Seats, both Seat Heater or Lumbar kit can be ordered as an easy to install DIT kit, or factory installed.



EXT010-1

Lumbar Kit for one seat

The lumbar pad inflates simply by squeezing the inflatable ball that fits into the palm of your hand until you reach the desired shape. To release the pressure, simply press the release button in front of the ball.

Easy to install DIY kits.....EXT010-1	\$ 79.00
Custom installed when ordering a new single seat.....EXT010-1IN	\$ 79.00



Product Information

Defender Standard Front Seats

The Standard Defender front replacement seat from Exmoor Trim is supplied complete with runners and all fixings. This is a direct replacement seat for the original front seating used up to 2007 in all Defenders. The seat base is removable, the headrest is adjustable, with reclining seat backs, rear pockets and smooth sliding runners. Don't settle for less, safety matters. Approved by Vehicle Certification Agency (VCA). Mark 1 Impact Tested (Millbrook Testing Ground). Approved worldwide and certification supplied with every seat.

Add Factory Installed Heat or Lumbar support to any seat, see p55.

EXT304-XSBR

Knob Recline Lever
PLF503 \$ 7.95

Defender Front Seats

LH, Black Vinyl.....EXT304-BV	\$ 642.31	LH, Blk Span Mondus...EXT304-BSM	\$ 683.40
RH, Black Vinyl.....EXT303-BV	\$ 642.31	RH, Blk Span Mondus...EXT303-BSM	\$ 683.40
LH, Dark Grey Vinyl.....EXT304-DGV	\$ 642.31	LH, XS 1/2 Leather.....EXT304-XSBR	\$ 754.76
RH, Dark Grey Vinyl.....EXT303-DGV	\$ 642.31	RH, XS 1/2 Leather.....EXT303-XSBR	\$ 754.76
LH, Caviar.....EXT304-CA	\$ 670.42	LH, Grey Leather.....EXT304-GL	\$ 798.02
RH, Caviar.....EXT303-CA	\$ 670.42	RH, Grey Leather.....EXT303-GL	\$ 798.02
LH, Twill Vinyl.....EXT304-DT	\$ 646.63	LH, Black Leather.....EXT304-BL	\$ 798.02
RH, Twill Vinyl.....EXT303-DT	\$ 646.63	RH, Black Leather.....EXT303-BL	\$ 798.02
LH, Car Denim Vinyl.....EX9605NAS	\$ 669.43	LH, Logo Tan.....EXT304-LRB	\$ 670.42
RH, Car Denim Vinyl.....EX9606NAS	\$ 669.43	RH, Logo Tan.....EXT303-LRB	\$ 670.42
LH, Techno.....EXT304-TC	\$ 670.42	LH, Logo Black.....EXT304-LRBK	\$ 683.40
RH, Techno.....EXT303-TC	\$ 670.42	RH, Logo Black.....EXT303-LRBK	\$ 683.40

Defender Front Seat Bottom Cushion

Twill Vinyl bottom cushion Driver/Pass.....PLF497	\$ 129.00
Car Denim Vinyl bottom cushion Driver/Pass.....PLF495	\$ 159.00
Dark Grey Vinyl bottom cushion Driver/Pass.....EXT310-DGV	\$ 139.00
Black Vinyl, Driver/Pass.....EXT310-BV	\$ 119.00

Product Information

Trim and Fabric Choices - Standard Defender seats as fitted to 1993-1997 NAS specification vehicles.

Note: Additional fabric selections are also available by special order on standard Defender seats, please see page 52 for swatches.



Twill Vinyl, grey lower vinyl - 1995 NAS Soft Top & 1997 SW



Rear pocket as fitted to Standard Defender NAS seats



Car Denim Vinyl, black lower vinyl - 1994 NAS Models & 1997 Soft Tops

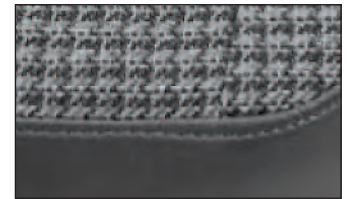

Moorland Cloth is now NLA- 1993 & 1995 90/110 NAS SW

Product Information

Defender Front Seat Retrim Kits

Exmoor Trim offers the Defender front seat kit as an alternative to replacing your entire front seat. This kit has been assembled with the vehicle restorer foremost in mind, allowing the individual to replace all the important external and internal small components that make all the difference to the finished job.

These kits only use OEM Denim and OEM vinyl sides and rear materials. The Retrim kits include all new foams and seat & headrest covers and spray adhesive. You are guaranteed to be able to strip your seats down, restore all the seat base foams and the covers in the knowledge that all the seat components you need to finish your seat restoration are to hand.



EXT315-DT

Standard Single Seat Retrim Kits

Includes; foams, back, bottom, headrest covers and spray adhesive.

Black Vinyl.....EXT315-BV	\$ 161.00
Dark Grey Vinyl.....EXT315-DGV	\$ 161.10
Caviar.....EXT315-CA	\$ 171.36
Techno.....EXT315-TC	\$ 195.00
Twill Vinyl, NAS spec.....EXT315-DT	\$ 163.36
Car Denim, NAS spec.....EXT315-NAS	\$ 169.00
Moorland.....EXT315-MR	\$ 229.00
XS 1/2 Leather.....EXT315-XSBR	\$ 261.18

Two Front Seat Retrim Kits

Pair, Dark Granite Leather.....EXT316-GL	\$ 589.00
Pair, Techno.....EXT316-TC	\$ 323.01
Pair, G4.....EXT316-G4	\$ 400.09

Pair, Logo Black.....EXT316-LRBK	\$ 481.29
Pair, Logo Brown.....EXT316-LRB	\$ 376.63
Pair, Denim Twill NAS.....EXT316-DT	\$ 308.31
Pair, Diamond White XS.....EXT316-DWXS	\$ 421.72
Pair, Diamond Red XS.....EXT316-DRXS	\$ 421.72
Pair, Diamond Black XS.....EXT316-DBXS	\$ 421.72
Pair, Dark Grey Vinyl.....EXT316-DGV	\$ 297.25
Pair, Caviar.....EXT316-CA	\$ 308.31
Pair, Black Vinyl.....EXT316-BV	\$ 297.25
Pair, Span Mondus.....EXT316-BSM	\$ 451.99
Pair, XS Black Rack.....EXT316-XSBR	\$ 544.50

Foam Replacement Cushions

Seat Base Front Outer.....EX3422	\$ 69.50
Seat Back Front.....EX776A	\$ 76.50



EXT300-DXS

EXT332-DT



EXT300-XSBR

NEW
Extended Defender Outer Seat Base

These new longer seat bases give superb support under your legs with standard raised sides for easy access.

A direct replacement for standard seat bases, these are now available in all fabric options shown on page 52.

To Install you simply clip out and clip in the new extended seat base it could not be easier. This is just what every Land Rover owner needs, a bit better support on and off-road which you get with this high grade moulded internal foam for long life.

These do give very good support for your legs and more so for the taller driver, coupled with our seat risers purchased separately to make a very good package.

Fits all Land Rover Genuine seats and Exmoor Trim Defender front outer seat assemblies.

Twill Vinyl bottom cushion Driver/Pass.....	EXT332-DT	\$ 190.31
Car Denim Vinyl bottom cushion Driver/Pass.....	EXT332-NAS	\$ 194.64
Dark Grey Vinyl bottom cushion Driver/Pass.....	EXT332-DGV	\$ 183.83
Black Vinyl, Driver/Pass.....	EXT332-BV	\$ 183.83

NEW

The Defender Elite Seat MK2

Product Information

is our most popular front seat for Series and Defender models. The Defender Elite seat has unsurpassed comfort, support, style and hold. Raised bolsters in the seat bottom and back give excellent longitudinal hold. A higher back also adds to superior comfort and support with advanced lumbar support. Reclines with adjustable twin stalk headrest and removable seat base for battery/storage access. Rear pocket as standard.

Also included as standard are pneumatic lumbar supports and seat heaters. A good all round seat ideal for on or off-road use. Our constant focus on quality with all our products ensures you get the best. Approved by Vehicle Certification Agency (VCA). Mark 1 Impact Tested (Millbrook Testing Ground). Approved worldwide and certification supplied with every seat. **Sold in pairs.**

Defender Elite Seat MK2

Pair, Diamond XS.....	EXT300-DXS	\$ 2608.78	Pair, Blk Span Mondus..	EXT300-BSM	\$ 2087.02
Pair, Black Vinyl.....	EXT300-BV	\$ 1943.80	Pair, XS 1/2 Leather	EXT300-XSBR	\$ 2578.09
Pair, Dark Grey Vinyl.....	EXT300-DGV	\$ 1943.80	Pair, Grey Leather	EXT300-GL	\$ 2844.08
Pair, Denim Twill Vinyl.....	EXT300-DT	\$ 1994.95	Pair, Black Leather	EXT300-BL	\$ 2844.08
Pair, Techno.....	EXT300-TC	\$ 2035.87	Pair, Logo Black	EXT300-LRBK	\$ 2015.41



SEAT RISER SET
FOR ONE FRONT SEAT DEFENDER
1984-2012 **RNA872** \$ 85.80

Lumbar Kit for One Seat

The lumbar pad inflates simply by squeezing the inflatable ball that fits into the palm of your hand until you reach the desired shape. To release the pressure, simply press the release button in front of the ball.

Easy to install DIY kits

EXT010-1 \$ 79.00

Custom installed in a new single seat.

EXT010-1IN \$ 79.00



Seat Heater Kits for two seats.

Goes great with our retrim kits or added to your existing front or rear seats. Sold in pairs. Includes wiring loom & Hi / Low Switches and instructions.

Easy to install DIY kit, fits into all types of Land Rover Seats.

EXT010-2 \$ 139.00

Custom installed when ordering a new seat pair

EXT010-2IN \$ 198.00





Premium High Back 2nd Row Seats

Pioneering Style & Comfort
Introducing the Premium High back seat for second row passengers in 109 and 110 Station Wagons.

Sold as single seats to be installed in any variety of combinations you choose. These are available as right hand, centre and left hand assemblies.

Each seat includes; seat base, under body mounting plate and mounting hardware. The seats utilise the existing second row seat belt configuration so there is no need to adapt your belts or you can purchase new seat belts from Rovers North.

Approved for child seats 0 to 6 months and booster seats 6 months onwards. The design shape of the seat has been specifically developed to hold a child restraint in place and the seats backs are all individually adjustable with a recliner action. Not isofix compatible.



Product Information



Add Factory Installed Heat or Lumbar support to any seat, see p 55.

Premium Key Features

- Improved leg room
- Rear storage pockets
- Individual seat back adjustment
- Adjustable twin stalk removable headrest
- Fold down seat backs
- Child seat SAFE
- Easy to install

Available Combinations

- Single RH or LH seat
- Two outside seats with walk-through isle
- Two outside seats with centre cubby box
- Three seats in a row



Above: Shown with premium Loc-Box fitted in centre seat position.



Two outside seats with walk-through isle shown providing easy access to rear lock and fold seats.

Premium High Back 2nd Row Seats

Black Vinyl, LHEXT010-3LH-BV \$ 867.88	XS Blk Rack, LHEXT010-3LH-XSBR \$ 1016.41
Black Vinyl, Centre.....EXT010-3C-BV \$ 867.88	XS Blk Rack, Centre.....EXT010-3C-XSBR \$ 1016.41
Black Vinyl, RH.....EXT010-3RH-BV \$ 867.88	XS Blk Rack, RH.....EXT010-3RH-XSBR \$ 1016.41
Dark Grey Vinyl, LHEXT010-3LH-DGV \$ 867.88	Logo Black, LHEXT010-3LH-LRBK \$ 899.00
Dark Grey Vinyl, Centre..EXT010-3C-DGV \$ 867.88	Logo Black, Centre.....EXT010-3C-LRBK \$ 918.12
Dark Grey Vinyl, RH.....EXT010-3RH-CGV \$ 867.88	Logo Black, RH.....EXT010-3RH-LRBK \$ 899.00
Caviar, LHEXT010-3LH-CA \$ 884.61	Diamond XS, LHEXT010-3LH-DXS \$ 1049.92
Caviar, Centre.....EXT010-3C-CA \$ 884.61	Diamond XS, Centre.....EXT010-3C-DXS \$ 1049.92
Caviar, RH.....EXT010-3RH-CA \$ 869.00	Diamond XS, RH.....EXT010-3RH-DXS \$ 1049.92
Denim Twill, LHEXT010-3LH-DT \$ 889.08	Diamond XS White, LH ..EXT010-3LH-DXSW \$ 918.12
Denim Twill, Centre.....EXT010-3C-DT \$ 889.08	Diamond XS W, Centre..EXT010-3C-DXSW \$ 918.12
Denim Twill, RH.....EXT010-3RH-DT \$ 889.08	Diamond XS White, RH..EXT010-3RH-DXSW \$ 918.12
Techno, LHEXT010-3LH-TC \$ 899.00	Diamond XS Red, LHEXT010-3LH-DRXS \$ 918.12
Techno, Centre.....EXT010-3C-TC \$ 913.65	Diamond XS R, Centre.....EXT010-3C-DRXS \$ 918.12
Techno, RH.....EXT010-3RH-TC \$ 913.65	Diamond XS Red, RH.....EXT010-3RH-DRXS \$ 918.12
Logo Tan, LHEXT010-3LH-LRB \$ 899.00	Diamond XS Blk, LHEXT010-3LH-DXSB \$ 918.12
Logo Tan, Centre.....EXT010-3C-LRB \$ 918.12	Diamond XS B, Centre.....EXT010-3C-DXSB \$ 918.12
Logo Tan, RH.....EXT010-3RH-LRB \$ 899.00	Diamond XS Blk, RH.....EXT010-3RH-DXSB \$ 918.12
Blk Span Mondus, LHEXT010-3LH-BSM \$ 918.12	
Blk Sp Mondus, Centre..EXT010-3C-BSM \$ 918.12	
Blk Span Mondus, RH.....EXT010-3RH-BSM \$ 899.00	



EXT050-MR

Product Information

Rear Jump Seats

Twill vinyl.....	EXT050-DT	\$219.00
Black Vinyl.....	EXT050-BV	\$219.00
Moorland cloth.....	EXT050-MR	\$249.00
Elephant grey vinyl.....	EXT050-EHG	\$214.46
Car Denim.....	EX9607NAS	\$248.00
Black Leather.....	EXT050-BL	\$369.00
Black Mondus Cloth.....	EXT050-BSM	\$240.24
Diamond Black XS.....	EXT050-DBXS	\$237.89
Dark Grey vinyl.....	EXT050-DGV	\$229.00
XS Black Rack.....	EXT050-XSBR	\$319.00



EXT050-BV

Product Information

Inward Facing Fold Up Seats

Black Vinyl.....	EXT054-BV	\$ 260.05
Caviar.....	EXT054-CA	\$ 271.93
Diamond Black XS.....	EXT054-DBXS	\$ 324.40
Dark Grey Vinyl.....	EXT054-DGV	\$ 262.28
Diamond Red XS.....	EXT054-DRXS	\$ 324.40
Denim Twill Vinyl.....	EXT054-DT	\$ 271.93
Diamond White XS.....	EXT054-DWXS	\$ 324.40
G4 Style.....	EXT054-G4	\$ 321.32
Grey Leather.....	EXT054-GL	\$ 475.78
LR Logo Brown.....	EXT054-LRB	\$ 288.25
LR Logo Black.....	EXT054-LRBK	\$ 312.32
Techno.....	EXT054-TC	\$ 288.25
XS 1/2 Leather.....	EXT054-XSBR	\$ 421.72
Black Leather.....	EXT054-BL	\$ 475.78
Diamond XS.....	EXT054-DXS	\$ 428.20
Black Span/Mondus Cloth.....	EXT054-BSM	\$ 313.82



EXT054-DXS



EXT054-DGV

Product Information

Rear Side Bench Seat Assembly

Optional folding, side facing, seat assembly as fitted to Series II through Defender up to 2007. Each seat is supplied with mounting hardware and retaining strap. Requires two lap type seat belts, see page 48. Folds up for additional storage when not in use. Available in all trim colours shown on page 52 by special order.



Available Options

Rear Side 2-Man Bench Seat Kit, Elephant Hide, Galvanized Frame.....	EXT003-EHG	\$ 248.00
Rear Side 2-Man Bench Seat Kit in Black Vinyl, Galvanized Frame.....	EXT003-BV	\$ 229.00
Rear Side Bench Seat Kit in Black Vinyl, Black Frame.....	PLB711	\$ 129.00
Bottom Cushion only in Black Vinyl.....	PLB708	\$ 48.20
Bottom Cushion only in Elephant Hide Vinyl.....	EXT005-EHG	\$ 69.50
Rear Side 3-Man Bench Seat Kit, Black Vinyl, Black Frame.....	EXT006-BV	\$ 269.00
Rear Side 3-Man Bench Seat Kit, Techno, Black Frame.....	EXT006-TC	\$ 319.95

Product Information

Defender NAS 90 Rear Seat Refurb and Retrim Kits, 110 60/40 kit

Exmoor Trim offers the NAS Bench seat refurb kit designed with the vehicle restorer in mind. Includes all base and back seat foams and trim covers with retaining clips. Uses OEM Car Denim vinyl fabric with high quality UV resistant black vinyl sides and rear.

Optional NAS 90 Forward Facing Bench Refurb Kit

Car Denim with Foams, Black Vinyl Sides and Back.....	PREM316-2CD	\$ 573.10
Optional NAS 90 Forward Facing Rear Bench Seat Retrim Kit.....	EXT331-10NAS	\$ 370.90
Retrim Kit 60/40 Seat NAS Defender 110, Car Denim Vinyl.....	EXT354-NAS	\$ 439.00



PREM316-2CD



EXT331-10NAS



Defender Headliner Sets

Product Information



Defender Headliner Sets

3-Piece OEM molded headliner set in Ripple Grey. Includes front, middle and rear headliner with an additional section that fits above the rear door. Has cutouts for front and rear interior lamps. For interior lamps use RNL159 and bracket RNN288, see page 79.

DEFENDER 90 LESS SUNROOF

RIPPLE GREY.....EXT405-1 \$ 699.00

DEFENDER 90 WITH FACTORY

SUNROOF.....EXT405-2 \$ 725.00

DEFENDER 110 STATION WAGON

LESS SUNROOF.....EXT405-3 \$ 999.00

DEFENDER 110 STATION WAGON

w/ FACTORY SUN ROOF.....EXT405-4 \$ 1029.00



Defender Interior Front Door Panel RH + LH Set

This door panel set is manufactured to fit 2-piece front doors on Land Rover Series III and Defender 90 vehicles fitted with anti-burst door latches. Replicas of the original that are NLA, speaker area is not pre-cut to allow for varying sizes.

Front Door Panel, Includes mounting hardware & instructions.....RNA4700 \$ 389.00

Interior Door Handle, Defender 90, 110, Genuine, Also fits Series...RNF474 \$ 4.99



Defender Interior Rear Door Panel, w/Pocket Net

Rear door panel is manufactured in the UK to fit Defender vehicles with anti-burst door latch as shown. Includes mounting hardware & instructions.

Fits: Defender 1983-'02.

Rear Door Panel, Black.....RNA2100 \$ 211.99

Rear Door Panel, Dark Grey (shown above).....RNA2101 \$ 211.99



Defender 90/110 Air Conditioning Kits

Update your Defender with the latest R134A Air Conditioning system as supplied on 2004 Defenders. Our exclusive Air Conditioning Kit for Defenders incorporates many improved components and features, including better ventilation and blower capacity for a faster, colder air. Includes; Lower dash fascia unit, blowers, compressor, lines, hoses, fittings, pulley, tensioner belt, evaporator, condenser and fan unit, receiver-drier, all hardware and fitting instructions.

Defender 90/110, 300 TDI, LHD.....	RNAC300	\$ 3399.00
Defender 90/110, 3.9L V8, LHD.....	RNAC39	\$ 3399.00
Defender 90/110, 4.0L V8, LHD.....	RNAC40	\$ 3960.00



Defender Radio Housing

Keep your eyes on the road. Makes for easy tuning and adjustments while driving. Can be used for a separate CB installation too. RNH512 \$ 119.95



RNA4600

Series Interior Trim

Front Door Interior Trim Set, Series IIA, III, RH+LH, Black Vinyl.....	EXT382-10	\$314.76
Front Door Interior Trim Set, Series IIA, III, RH+LH, Elephant Hide.....	EXT382-25	\$399.00
Middle Door Panel Upper 109", RH, Black Vinyl.....	EXT382-12	\$ 45.33
Middle Door Panel Upper 109", LH, Black Vinyl.....	EXT382-11	\$ 45.33
Middle Door Panel Upper 109", RH, Elephant Hide Vinyl.....	EXT382-27	\$ 61.19
Middle Door Panel Upper 109", LH, Elephant Hide Vinyl.....	EXT382-26	\$ 61.19
Middle Door Panel Lower 109", RH, Black Vinyl.....	EXT382-14	\$ 58.92
Middle Door Panel Lower 109", LH, Black Vinyl.....	EXT382-13	\$ 58.92
Middle Door Panel Lower 109", RH, Elephant Hide Vinyl.....	EX6281	\$ 68.90
Middle Door Panel Lower 109", LH, Elephant Hide Vinyl.....	EXT382-28	\$ 74.79
Insulated Rubber Floor Mat Set Front Pair, Series II, IIA, III.....	EXT017-1	\$ 89.95
Rear Door Interior Trim, Series IIA, III, Black Vinyl.....	EXT382-15	\$ 54.00
Rear Door Interior Trim, Series IIA, III, Elephant Hide Vinyl.....	EXT382-30	\$ 79.50



EX2831

Above: Middle door 109" Series IIA restored by Lanny Clark, sold by Orvis.

EXMoor Trim take yourself on an adventure™



ex Moor
pre Mium



EXT021-2

NEW Premium Complete Carpet Sets for Defender

Made with OEM material for superior finish and sound proofing. Available in Ebony.

This complete vehicle package is available for most Defender models with LT77 or R380 Gearbox and carpets the entire vehicle front to back with precision cut panels covering all the wheel arches and seat box in entirety.

90" LT77 Gearbox, Ebony.....	EXT021-2	\$ 529.85
90" R380 Gearbox, Ebony.....	EXT021-3	\$ 540.66
110" Station Wagon LT77 Gearbox, Ebony.....	EXT021-4	\$ 594.73
110" Station Wagon R380 Gearbox, Ebony.....	EXT021-5	\$ 594.73
110" Crew Cab LT77 Gearbox, Ebony.....	EXT021-6	\$ 508.22
110" Crew Cab R380 Gearbox, Ebony.....	EXT021-7	\$ 508.22
Standard Front Carpet Set, Defender LT77.....	EXT020-2	\$ 194.33

Product Information

EXT009-13



EXT009-13

Defender Moulded Matting System

The Molded Matting System from Exmoor Trim has been specifically designed to increase ride comfort by greatly reducing heat and road noise.

The 3 piece matting system is manufactured entirely from black cast dense polyurethane using precision injection mold tooling.

The black floor mat is a one piece floor section that covers the driver's / passenger's foot-wells and the gearbox tunnel. This design feature ensures maximum soundproofing and heat suppression.

The black one piece seat box cover encases the 3 open sides of the seat box to also greatly reduce noise and heat.

This kit is available for both Defender NAS and RoW models with LT77, R380 manual transmissions and ZF Automatics.

NOTE: Some trimming is required when installing the Black Molded Matting Systems in LT77 and Automatic transmissions. The kit is also supplied with a bulkhead panel and the seat box cover is one piece and will require specific fitting.

R380 3-Piece Black Front Moulded Matting Set

Front floors, seatbox, bulkhead.....	EXT009-13BK	\$ 713.67
LT77 3-Piece Molded Matting Set - floors, seatbox, bulkhead.....	EXT009-12BK	\$ 713.67
Moulded Rubber Mat Defender V8, 300TDI & TD5 up to 2007, Grey.....	EXT009-13	\$ 713.67



EXT021-5



Which Defender gearbox do I have?

LT77, LT77S - Reverse is forward to the left.
R380 - Reverse is rearward to the right.



LT77
LT77S



R380



RNO691 Rigid Protector



RNO688



RNO689

Rubber Floor Mats

Defender

Defender 90 Loadspace Mat, Genuine.....	RNF468	\$ 279.95
Defender 90 NAS Loadspace Mat, Genuine.....	RNI075	\$ 339.95
Defender 90 SW non-NAS, Loadspace Mat, Genuine.....	RNI061	\$ 349.95
Defender Rubber Mat Set Front, Pre '07, Genuine.....	RNN213	\$ 158.50
Defender Rubber Mat Set Front, Pre '07, ProLine.....	EXT017-2	\$ 69.12
Defender Rubber Mat Set Front, 2007+, Genuine.....	RNS556	\$ 169.00
Defender Rubber Mat Set Front, 2012+, Genuine.....	RNQ690	\$ 150.34
Defender Front Insulated One-Piece Molded Floor Mat, V8, 300Tdi, & TD5, Black Rubber, Genuine.....	RNN717	\$ 257.95
Defender 110 SW, Rubber Mat Set Middle Footwell, Genuine.....	RNI070	\$ 139.95
Defender 110 SW, Rubber Mat Set Middle Pair, Genuine.....	RNQ689	\$ 168.82
Defender 110 SW, Rubber Mat Set Front Footwell, Genuine.....	RNI067	\$ 149.95
Defender 110 SW Loadspace Mat, Genuine.....	RND268	\$ 349.95
Defender 110 Loadspace Mat 5 Door Hard Top, 2007+, Genuine.....	RNQ688	\$ 299.98
Defender 110 Loadspace Mat, 2007+, Genuine.....	RNQ777	\$ 367.44
Defender 110, Genuine.....	RNQ691	\$ 409.24
Defender (LT77 & R380 up to 2007) Moulded Floor Mats Front Pair, Exmoor.....	EXT017-2	\$ 69.12
Defender Middle Row, Moulded Floor Mats, Exmoor.....	EXT017-3	\$ 69.12
Floor Mat 109/110 Regular Rear.....	PLB792R	\$ 69.20

Series Land Rover

Series II, III Floor Mat Set, Front Pair, Exmoor.....	EXT017-1	\$ 89.95
Series IIA, III Floor Mat, 109" SW Middle, Genuine.....	RNB791	\$ 109.32
Series IIA, III Floor Mat, 109" SW Middle, ProLine.....	PLB791	\$ 34.50
Series 88" Floor Mat Rear, 47"x36", ProLine.....	PLB786	\$ 49.95
Series Middle Row, Moulded Floor Mats, Exmoor.....	EXT017-3	\$ 69.12
Loadspace, Exmoor.....	EXT009-1	\$ 129.95

Discovery I 1994-1999

Front & Middle Rubber Floor Mat Set, Genuine.....	RNA626	\$ 229.95
Front Mat, ProLine.....	PLH756	\$ 79.50
Moulded Floor Mats Front Pair Discovery I, Exmoor.....	EXT017-8	\$ 69.12
Middle Mat, ProLine.....	PLH756B	\$ 79.50
Loadspace Mat w/out Rear A/C, Genuine.....	RNA674	\$ 199.95

Discovery II 1999-2004

Mat Center Console, Black DII Automatic, Genuine.....	RNQ909	\$ 38.83
Front Rubber Floor Mat, Pair, Genuine.....	RNA708	\$ 129.95
Moulded Mat Set Front Pair, Discovery II Black.....	EXT017-11	\$ 69.12
Front & Middle Rubber Floor Mat Set, Genuine.....	RNA676	\$ 179.95
Moulded Floor Mats For Middle Row Discovery II (Pair), Exmoor.....	EXT017-12	\$ 69.12
Rubber Loadspace Mat, Half Length, Genuine.....	RNA683	\$ 219.95
Loadspace Mat - Discovery II, Genuine.....	RNQ817	\$ 238.50

Range Rover Classic 1987-1995

Short Wheel Base Front & Middle Rubber Floor Mat Set, Genuine..	RNA624	\$ 153.47
---	--------	-----------

RNS556 Defender 2007+
RNO690 Defender 2012+



RNI581 Range Rover 2003-'07



RNI584 Range Rover Sport 2006-'09

Range Rover 2003-2009

Front & Middle Rubber Floor Mat Set

2003-'07, Genuine.....	RNI581	\$ 224.95
2008-'09, Genuine.....	RNI582	\$ 259.95

Loadspace Mat, Genuine.....

RNI583	\$ 269.95
--------	-----------

Range Rover Sport 2006-2009

Rubber Floor Mat Set

2006-'07, Genuine.....	RNI577	\$ 219.95
2008-'09, Genuine.....	RNI578	\$ 269.95

Rubber Mat Set Front Pair

L320 Sport BLK.....	RNO819	\$ 178.95
---------------------	--------	-----------

Loadspace Mat, Genuine.....

RNI584	\$ 249.95
--------	-----------



RNI579 LR3 2005-'09



RNI575 LR2 2008-'09

LR3 2005-2009

Front & Middle Rubber Floor Mat Set

Genuine.....	RNI579	\$ 229.95
--------------	--------	-----------

Loadspace Mat, Genuine.....

RNI580	\$ 74.95
--------	----------

Loadspace Mat, For use without

3rd Row Seats, Genuine.....	RNL715	\$ 219.95
-----------------------------	--------	-----------

Loadspace Mat,

Semi Ridged, ProLine.....	RNA319	\$ 99.84
---------------------------	--------	----------

LR2 2008-2009

Front & Middle Rubber Floor Mat Set

Genuine.....	RNI575	\$ 159.95
--------------	--------	-----------

Rear Loadspace Mat

Genuine.....	RNI576	\$ 199.95
--------------	--------	-----------



EXT0096

EXT0091

Insulated Rubber Floor Mats

Defender

Front Set, 4 Cylinder, Exmoor.....	EXT017-2	\$ 69.12
Loadspace, 90, 110 SW, Exmoor.....	EXT009-1	\$ 129.95
Loadspace, 110, 2 door, Exmoor.....	EXT009-10	\$ 145.08
Moulded Matting System 3-PC R380 Black, Series & Defender.....	EXT009-13BK	\$ 713.67
Loadspace Mat, Series 109, Defender 110 Regular, Exmoor.....	EXT009-10	\$ 145.08
Exmoor Rear Acoustic Mat System 3-Piece Set, Series, Defender.....	EXT009-14	\$ 299.00
Insulation Pad Front Seatbase Defender.....	RNI865	\$ 259.95

RNI865

A Defender Dashboard, Guages

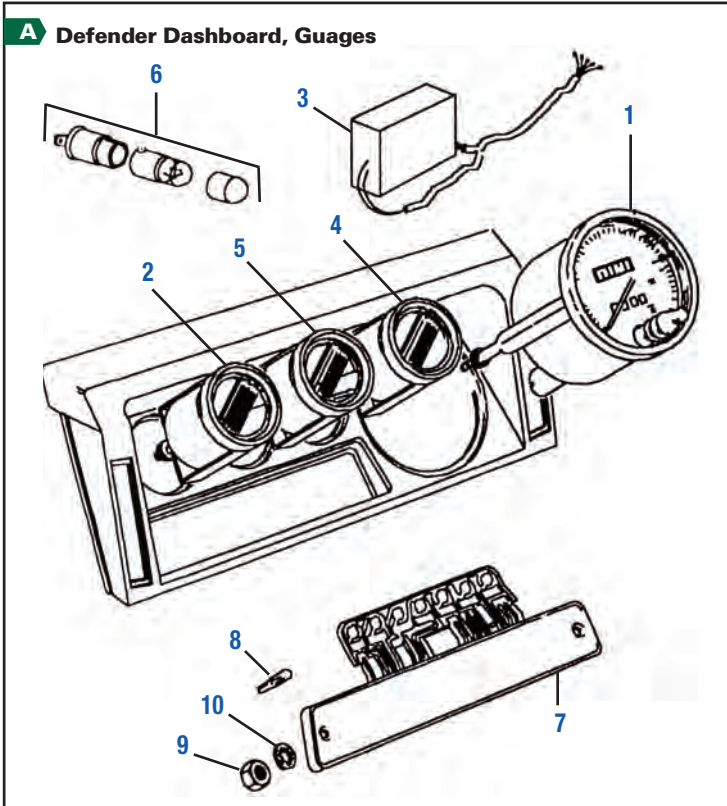

A Defender Dashboard, Guages

1. SPEEDOMETER - D90 MANUAL AND 110, GENUINE	RNE515	\$ 739.95
SPEEDOMETER MPH DEFENDER 90/110, PROLINE.....	PLE515	\$ 349.00
SPEEDOMETER - D90 AUTOMATIC, GENUINE	RNC862	\$ 769.95
SPEEDOMETER BULB, GENUINE	RNC859	\$ 1.95
2. WATER TEMP GAUGE - D90 MANUAL & 110, GENUINE.....	RNC856	\$ 319.95
WATER TEMP GAUGE - DEFENDER, PROLINE.....	PLC856	\$ 145.95
WATER TEMP GAUGE - D90 AUTOMATIC, GENUINE	RNC863	\$ 399.95
WATER TEMP GAUGE BULB, GENUINE	RNC859	\$ 1.95
3. STABILIZER - D90 MANUAL AND 110, GENUINE	RNC855	\$ 169.95
4. FUEL GAUGE - D90 MANUAL, GENUINE.....	RNI603	\$ 485.42
FUEL GAUGE - D90 AUTOMATIC, GENUINE	RNC864	\$ 456.18
FUEL GAUGE - 110, GENUINE.....	RNC847	\$ POA
FUEL GAUGE BULB, GENUINE.....	RNC859	\$ 1.95
5. TACHOMETER - D90 MANUAL AND 110, GENUINE.....	RNC846	\$ POA
TACHOMETER - D90 AUTOMATIC, GENUINE.....	RNI604	\$ 614.91
6. BULB, HOLDER & FILTER - D90 MANUAL,D90 AUTO, 110"	RNI605	\$ POA
7. WARNING LIGHT MODULE - D90 MANUAL,D90 AUTO, 110	RNC853	\$ POA
8. 1.2 WATT BULB , GENUINE	RNE673	\$ 3.26
1.2 WATT BULB, PROLINE.....	PLE673	\$ 0.69
9. NUT 4mm, GENUINE.....	RNI606	\$ 0.95
10. STARLOCK WASHER M4, GENUINE	RNI607	\$ 1.25

B Defender Dashboard Gauge Panel

1. INSTRUMENT PANEL COWL - D110, GENUINE.....	RNI620	\$ 97.98
INSTRUMENT PANEL COWL - D90, GENUINE.....	RNI621	\$ 87.95
2. COWL SCREW -D90, D110, GENUINE.....	RNI622	\$ 2.59
3. PLAIN WASHER - D90, D110, GENUINE	RNI623	\$ 0.95
4. LOCK WASHER 5mm - D90, D110, GENUINE.....	RND115	\$ 1.95
6. PLASTIC CAPTIVE NUT - D90, D110, GENUINE.....	RNC946	\$ 2.95
PLASTIC NUTSERT SERIES & DEFENDER, PROLINE	PLC946	\$ 0.45
7. COWL STIFFENER - '94-'95 D90, D110, GENUINE.....	RNI624	\$ 98.95
COWL STIFFENER - '97 D90, GENUINE.....	RNI625	\$ POA
8. SCREW - D110, GENUINE.....	RNI626	\$ 1.69
SCREW - D90, GENUINE	RNI205	\$ 0.59
9. DASH COWL WASHER - D110 ONLY, GENUINE.....	RNI627	\$ 0.79

B Defender Dashboard Gauge Panel

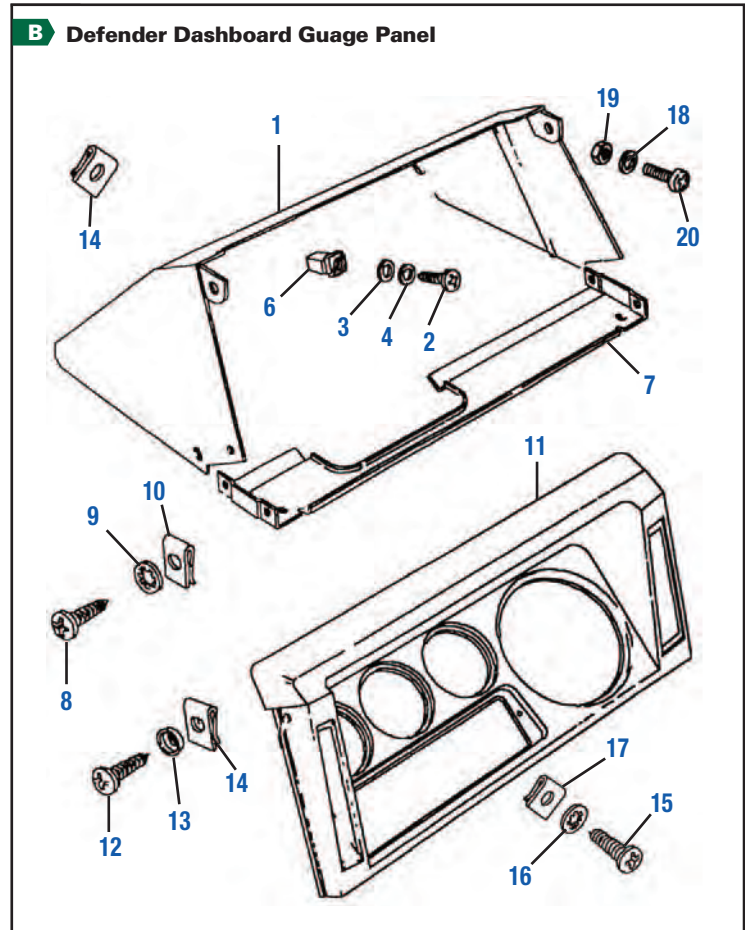

10. SPRING NUT - D90, D110, GENUINE	RNI627	\$ 0.79
11. INSTRUMENT PANEL - D110, GENUINE.....	RNI629	\$ 124.95
INSTRUMENT PANEL - D90.....	RNI630	\$ POA
12. SCREW - D90, D110.....	RNI631	\$ 0.79
13. WASHER CUP - D90, D110	RNI632	\$ 1.25
14. FIXED NUT - D90, D110.....	RNI633	\$ 1.99
15. SCREW - D90, D110.....	RNI634	\$ 0.79
16. WASHER - D90, D110.....	RNI635	\$ 0.75
17. FIXED NUT - D90, D110.....	RNI633	\$ 1.99
18. LOCK WASHER 5mm - D90 ONLY	RND115	\$ 1.95
19. M5 NUT - D90 ONLY	RND112	\$ 1.79
20. SCREW M5 x 16mm - D90 ONLY.....	RNE033	\$ 1.95

Land Rover Genuine Guages & Bulbs for Defender

SPEEDOMETER - D90 AUTOMATIC, GENUINE	RNC862	\$ 769.95
WATER TEMP GAUGE - D90 MANUAL & 110, GENUINE.....	RNC856	\$ 319.95
WATER TEMP GAUGE - DEFENDER, PROLINE.....	PLC856	\$ 145.95
1.2 WATT BULB, GENUINE.....	RNC856	\$ 319.95
1.2 WATT BULB, PROLINE.....	PLE673	\$ 0.69
FUEL GAUGE BULB, GENUINE.....	RNC859	\$ 1.95





Exmoor Trim Canvas Seat Covers

Exclusive deep weave canvas cover for comfort are durable, waterproof and washable. All sets are SRS compatible, feature double stitched seams with tasteful leatherette piping and front and rear pockets. Includes head and arm rest covers.

DISCOVERY I		
FRONT, SAND PAIR.....	EXT019-19	\$ 291.96
FRONT, GREY PAIR.....	EXT019-20	\$ 291.96
FRONT, BLACK PAIR.....	EXT019-37	\$ 291.96
DISCOVERY II		
FRONT, SAND, PAIR.....	EXT019-25	\$ 313.58
FRONT, GREY PAIR.....	EXT019-26	\$ 313.58
FRONT, BLACK, PAIR.....	EXT019-40	\$ 313.58
60/40 SEAT SET, GREY.....	ETUSA019-55	\$ 200.95
LR3		
FRONT LR3, SAND PAIR.....	EXT019-31	\$ 335.21
FRONT LR3, BLACK PAIR.....	EXT019-52	\$ 637.98
LR4		
FRONT LR4, SAND PAIR.....	ETUSA019-61	\$ 327.80
FRONT LR4, GREY PAIR.....	ETUSA019-62	\$ 209.95
FRONT LR4, BLACK PAIR.....	ETUSA019-63	\$ 224.43
DEFENDER		
DEFENDER PRE-07 GREY CANVAS, PAIR.....	ETUSA019-13	\$ 183.72
FRONT PUMA 07+ BLACK CANVAS, PAIR.....	ETUSA019-11	\$ 187.90
FRONT PUMA 07+ GREY CANVAS, PAIR.....	ETUSA019-17	\$ 187.90
FRONT 1983-2006, SAND PAIR.....	EXT019-1	\$ 280.06
FRONT 1983-2006 BLACK PAIR.....	EXT019-45	\$ 280.06
FRONT 2007-2015 SAND PAIR.....	EXT019-5	\$ 359.00
60/40 DEF PRE-07 GREY CANVAS.....	ETUSA019-14	\$ 169.95
60/40 DEF PRE-07 BLACK CANVAS.....	ETUSA019-8	\$ 179.55
60/40 PUMA 07+ BLACK CANVAS.....	ETUSA019-12	\$ 221.30
60/40 PUMA 07+ GREY CANVAS.....	ETUSA019-18	\$ 221.30
60/40 SEAT SET, 1993-2006, SAND.....	EXT019-8	\$ 227.08
60/40 SEAT SET 2007-2015, SAND.....	EXT019-8	\$ 227.08
DEFENDER & SERIES REAR SIDE FACING JUMP SEAT		
REAR LOADSPACE JUMP SEAT, SAND SINGLE.....	EXT019-12	\$ 86.12
REAR LOADSPACE JUMP SEAT, GREY SINGLE.....	EXT019-11	\$ 86.12
REAR LOADSPACE JUMP SEAT, BLACK SINGLE.....	EXT019-50	\$ 86.12



EXT0182GRY



Exmoor Trim Nylon Waterproof Seat Covers

These are manufactured from an exclusive waterproof material that is totally non slip. This means that you won't slide off the seat and the cover won't slide on the seating fabric. All our waterproof seat covers are specifically tailored to fit each seat. This guarantees they will enhance the interior unlike a baggy seat cover. Front covers are a one piece cover with a large rear pocket.

DISCOVERY I		
FRONT BLACK PAIR.....	EXT18-21	\$ 91.61
60/40 SEAT SET, BLACK.....	EXT18-22	\$ 96.85
DISCOVERY II		
FRONT, GREY PAIR.....	EXT018-26GRY	\$ 199.95
FRONT, BLACK PAIR.....	EXT018-26	\$ 199.95
60/40 MIDDLE SEAT, BLACK.....	EXT018-27	\$ 299.95
60/40 MIDDLE SEAT, GREY.....	EXT018-27GRY	\$ 237.75
LR3		
FRONT, GREY PAIR.....	EXT018-30GRY	\$ 199.00
FRONT, BLACK PAIR.....	EXT018-30	\$ 199.00
LR4		
FRONT, GREY PAIR.....	EXT018-34GRY	\$ 199.00
FRONT, BLACK PAIR.....	EXT018-34	\$ 199.00
DEFENDER		
FRONT 1983-2006, SAND PAIR.....	EXT0182SND	\$ 99.50
FRONT 1983-2006, GREY PAIR.....	EXT018-2GRY	\$ 99.50
FRONT 1983-2006, BLACK PAIR.....	EXT018-2	\$ 99.50
FRONT 2007-2015, GREY PAIR.....	EXT018-18GRY	\$ 104.20
FRONT 2007-2015, BLACK PAIR.....	EXT01818	\$ 109.99
60/40 SEAT SET 1993-2006 110, 130, GREY.....	EXT018-6GRY	\$ 129.00
60/40 SEAT SET 1993-2006 110, 130, BLACK.....	EXT018-6	\$ 129.00
60/40 SEAT SET 2007-2015 110,130, GREY.....	EXT018-19GRY	\$ 167.27
60/40 SEAT SET 2007-2015 110, 130, BLACK.....	EXT018-19	\$ 167.27
REAR LOADSPACE JUMP SEAT 1959-2006, GREY SINGLE.....	EXT0187GRY	\$ 49.50
REAR LOADSPACE JUMP SEAT 1959-2006, BLACK SINGLE.....	EXT018-7	\$ 49.50
REAR LOADSPACE SEAT SET 2007-2015, BLACK PAIR.....	EXT018-20	\$ 89.00



Snow Shield for Defender Heater Intake

Injection moulded black ABS plastic cover for wing top heater intake. Protects heater from ice and snow build up and improves heater performance while driving in rain and snow storms. A must for Defenders operating in northern climates. Easy to install, includes mounting hardware.

FITS: Defender models 1983-2015 LHD.
NOTE: RHD model is available by special order. Please inquire.

RNA2102 \$ 49.95



NEW

Slickshift Shift Lever Upgrade Kit for Defender LT77, R380 (inc Td5)

This new, innovative design dramatically improves your driving experience. Built for 5-speed Land Rover Defender LT77 / R380 gearboxes, Slickshift improves gear changes by minimizing the gear lever travel. This creates quick, precise and noticeably smoother gear shifts every time. Installs quickly and easily from the interior of your Defender. Requires no drilling, or special tools. Made in the UK by Syncroworks Developments. **FITS:** Defender 5 speed LT77, LT77S and R380 gearbox main lever bases from 1984 - 2006.

RNA345 \$ 179.00



NEW Defender 90 NAS Roll Bar Covers



PREM202-12



Discovery Shift & Brake Lever Boot Gaiter Kit

E-brake and transfer boot gaiter kit...PLK130 \$ 29.99
 Gaiter, Hand Brake Lever.....PLN953B \$ 21.99
 Gaiter, Transfer Lever.....PLN952B \$ 14.50



PLN953B

PLN952B

RND490

NEW Defender 90 NAS roll bar cover vehicle kit

New padded foam covers for your NAS roll bar. Easily installed and easily cleaned. Adds an extra layer of comfort and looks great too.

PREM202-12 \$ 299.00

Discovery I, II Genuine Land Rover Cup Holder Kit

For both Discovery I & II, this Genuine Land Rover cup holder is the perfect addition to your interior. It features a slip-in molded insert for smaller drinks and has a non-slip bottom to keep the spills to a minimum, shown above. Includes two cup holders.

*Will not fit 2003 or 2004 vehicles.
 Beige RND490 \$ 79.95
 Smokestone RND491 \$ 79.95



RND491



EXT015PREM-LXV

exmoor
preMium



Premium non-locking Cubby Box features an improved 50mm padded lid for comfort and arm support between the seats. Four individual moulded feet are designed to fit into the pre-drilled Land Rover fixings found on most Defender Models. Includes a removable moulded plastic cup insert and fully lined carpet interior. Uses the OEM lid closure to prevent unnecessary rattles.

Designed to fit all Defenders models. Can be easily adapted to fit Series II-III Land Rover models. Width: 270mm, Height: 325mm, Length: 485mm



EXT015PREM-XSLRB

- XS Grey Vinyl, White StitchingEXT015PREM-XS \$ 249.00
- XS Grey Vinyl, w/Perf Centre Panels-White StitchingEXT015PREM-XSPERF \$ 279.00
- LXV Style, w/Perf Centre Panels-Orange StitchingEXT015PREM-LXV \$ 299.00
- XS Grey Vinyl & Logo Black Centre Panel-Green Stitching ..EXT015PREM-XSLRBK \$ 299.00
- XS Grey Vinyl & Logo Tan Centre Panel-Tan StitchingEXT015PREM-XSLRB \$ 299.00
- Full Black Leather-Black Stitching.....EXT015PREM-BL \$ 389.00
- Diamond XSEXT015PREM-DXS \$ 279.00
- XS Black Rack.....EXT015PREM-XSBR \$ 329.00



TUFFY
SECURITY
PRODUCTS

Tuffy Security Box Stereo Console

This convenient 16-gauge steel security console has 2 compartments, a separate compartment for mounting a stereo, CB Radio, or other electronic equipment, and a lockable rear storage space lined with a rubber floor mat. The spacious rear compartment accommodates a CD changer, tools, and other valuables. Requires mounting package (listed below) specifically designed for Land Rover Defender 90, RNA1702, years up to '95, does not fit 1997 Defender 90 automatic. Will fit Series Land Rover models.

- Tuffy Security Box with Stereo Console, Black.....RNA1701 \$ 319.00
- Tuffy Security Box with Stereo Console, Charcoal.....RNA1703 \$ 319.00
- Tuffy Security Box Stereo Console, BlackRNA1700 \$ 329.00
- Tuffy Drink Holder, Black 4.5" x 7.875"RNA1704 \$ 39.95
- Tuffy Mounting Kit, Series, DefenderRNA1702 \$ 14.95

Tuffy Rear Speaker & Storage Security Lockbox Set

Mounts in the right and left rear wheel well area of your Defender to provide a convenient and secure place to mount 6"x9" speakers, and lock up valuables. This 16 gauge steel lockbox set comes equipped with a removable partition which divides the speaker and storage area.

Exterior Dimensions:

(Length is Tapered)
24 1/2"L to 19 1/2"L x
8 5/8"W x 9 5/8"H

Storage Compartment

Dimensions:
14 3/4"L x 8 1/4"W x 9"H

RNA2001 \$ 349.00



Rovers North Radiator Muffs

In the snowbelt, this simple accessory will make a big difference in your Land Rover's winter performance. By controlling the air flow through the radiator in freezing weather, the engine can run at its optimum operating temperature. This means reduced engine wear and increased heater output. Features superior materials and construction for improved durability and function.

- Early Series II, IIA w/headlamps in grillRNM0001 \$ 49.50
- Late Series IIA w/headlamps in wings.....RNM0002 \$ 49.50
- Series IIIRNM0003 \$ 49.50
- Defender 90, 110RNM0004 \$ 49.95



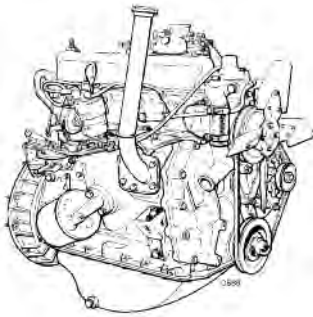

Series II, IIA, III 2.25 Litre

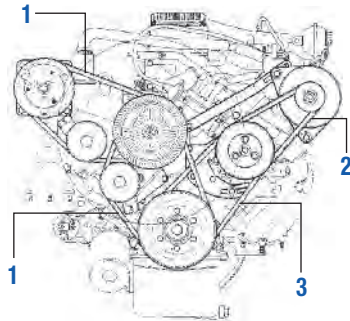

Range Rover Classic 1987-'92
V8, 3.9, 4.0 Litre

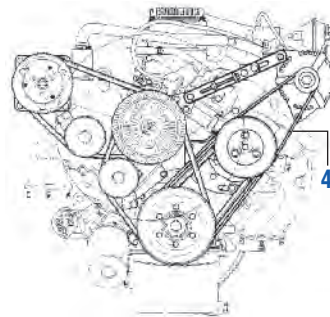

Range Rover Classic 1993-'94
Defender 90, 110 1993-'95
V8, 3.9, 4.0 Litre

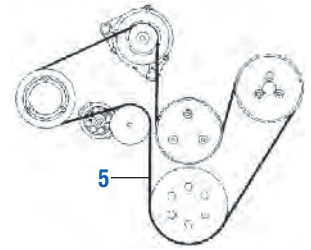

Range Rover Classic 1995,
Discovery I 1994-'99,
Defender 90 1997 V8, 4.0 Litre

4 Cylinder, 2.25, 2.5, V8 Fan Belts

Series I, II, IIA, III 4 Cylinder, 2.0, 2.25 litre

Fan Belt, 2.0 Litre Series I, II.....	RNF332	\$	POA
Fan Belt, 2.25 Litre Series IIA, III.....	RNC422	\$	12.95
Fan Belt, 2.6L Viscous, Series III, non-NADA.....	RNN967	\$	11.90
Fan Belt, Water Pump 24V, Single Belt.....	RNC288	\$	35.65

Defender 4 Cyl, V8, 3.9, 4.0 liter

1. Drive Belt, A/C Compressor & Water Pump.....	RNC001	\$	21.95
Drive Belt, A/C Compressor & Water Pump.....	PLC001	\$	10.90
3. Drive Belt, Power Steering Pump, 3.9ltr V8.....	RNC004	\$	34.95
Drive Belt, Power Steering Pump, 3.9ltr V8.....	PLC004	\$	9.50
Drive Belt, Power Steering, 2.5ltr 4-cyl Defender.....	RNL216	\$	32.00
Drive Belt, Water Pump / Alternator, Defender 90, 110 4 cyl.....	RNE153	\$	24.95
Drive Belt, Air Compressor, 90/110 w/carbs.....	RNN968	\$	40.96
Drive Belt Kit, V8 Defender 110.....	RNK1622	\$	114.50
Drive Belt Kit, V8 Defender 90.....	RNK1621	\$	110.59

Range Rover Classic, Discovery I, Defender 3.9, 4.0 ltr V8

1. Drive Belt, A/C & Water Pump, 3.5L V8, 3.9L 1987-'94, Genuine.....	RNC001	\$	21.95
Drive Belt, A/C & Water Pump, 3.5L V8, 3.9L 1987-'94, ProLine.....	PLC001	\$	10.90
2. Drive Belt, Alternator, 3.5L V8, 3.9L to 1987-'92.....	RNC002	\$	12.95
3. Drive Belt, Power Steering, 1987-'94, Genuine.....	RNC004	\$	34.95
Drive Belt, Power Steering, 1987-'94, ProLine.....	PLC004	\$	9.50
4. Drive Belt, Alternator, 4 groove, 1993-'94, Genuine.....	RNC003	\$	39.95
Drive Belt, Alternator, 4 groove, 1993-'94, ProLine.....	PLC003	\$	14.95
5. Serpentine Belt, RRC 3.9 /4.2 ltr 1995 & Disco I 3.9 ltr 1994-'95.....	RNC005	\$	44.95
Serpentine Belt, Discovery I 4.0 ltr, 1996-'99.....	RNC006	\$	39.99
Fan Belt Kit, Range Rover Classic 1987-'92, Genuine.....	RNK162	\$	84.99
Fan Belt Kit, Range Rover Classic 1993-'94, ProLine.....	PLK1623	\$	36.29
Fan Belt Kit, Range Rover Classic 1993-'94, Genuine.....	RNK1623	\$	99.80

Discovery II, Range Rover P38A, L322, L320 and LR3 Belts

Discovery II 4.6 litre V8 engine with ACE (Active Cornering Enhancement) and Air Conditioning

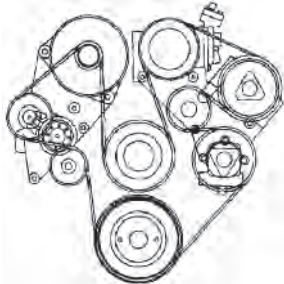

Discovery II Serpentine Belt Layout, with ACE

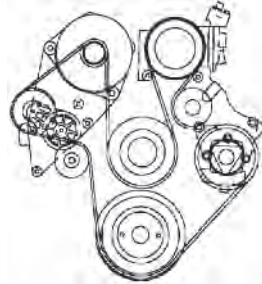

Discovery II Serpentine Belt Layout, without ACE

Discovery II Serpentine Belts

Discovery II w/o ACE, with Air Conditioning, 1999-'02.....	RNH145	\$	49.95
Discovery II with ACE, with Air Conditioning, 1999-'02.....	RNH147	\$	49.95

Range Rover P38A Belts

Alternator Belt, Poly V, Range Rover P38A, 1999 on.....	RNH533	\$	49.95
Drive Belt, Serpentine, P38A, 1995-'98, GEMS.....	RND001	\$	39.95

LR3, Range Rover L322 & L320 Belts

Serpentine Belt, 4.4L, L322, M62 BMW Primary.....	RNI384	\$	41.95
Serpentine Belt, 4.4L, L322, M62 BMW Secondary.....	RNI370	\$	30.35
Poly V Belt, Secondary, 4.4L V8.....	RNI358	\$	21.96

Defender 2.5 Diesel Belts

300 Tdi



Drive Belts

Drive Belt for fan and alternator, 2.5 NA, 2.5 Turbo, Genuine.....	RNE153	\$	24.95
Drive Belt for fan and alternator, 200 Tdi, Genuine.....	RNE153	\$	24.95
Drive Belt for A/C compressor, 200 Tdi, Genuine.....	RNL273	\$	48.10
Drive Belt for power steering, 200 Tdi, 2.5 NA, 2.5 Turbo, Genuine.....	RNL216	\$	32.00
Drive Belt - 7 groove for fan, water pump, alt, 300 Tdi, Genuine.....	RND297	\$	29.50
Drive Belt - 4 groove for A/C compressor, 300 Tdi, Genuine.....	RND295	\$	18.99
Drive Belt, w/air conditioning, Td5, Genuine.....	RND299	\$	37.01
Drive Belt, w/o air conditioning, Td5, Genuine.....	RND298	\$	39.95

Timing Belts

Timing Belt, 2.5 NA, 2.5 Turbo, Genuine.....	RNL551	\$	119.29
Timing Belt, 200 Tdi, Genuine.....	RNL477	\$	94.00
Timing Belt, 300 Tdi, Genuine.....	RNL456	\$	98.95
Timing Belt Tensioner early up to vin #VA117353, 300 Tdi, Genuine.....	RNN066	\$	113.35
Timing Belt Tensioner early up to vin #VA117353, 300 Tdi, ProLine.....	PLN066	\$	89.50
Timing Belt Tensioner, 200 Tdi, Genuine.....	RNL539	\$	149.95

300 Tdi Genuine Land Rover Timing Upgrade Kit

Upgrades all 300 Tdi engines to the latest timing components.

Kit includes timing idler, tensioner pulley, crankshaft gear, gasket,

timing belt and fixing hardware, Genuine.....RNN339 \$ 199.95

Tdi Timing Belt Service Kits

Includes Dayco belt, front gasket, tensioner and idler pulleys.

Timing Belt Kit Defender, 200 Tdi, ProLine.....	TBK2002	\$	89.95
Timing Belt Kit, up to vin #VA117353, 300 Tdi, ProLine.....	TBK300E	\$	119.95
Timing Belt Kit, from vin #VA117354, 300 Tdi, ProLine.....	TBK300L	\$	99.95
Tdi Timing Tool Kit (See page 81), ProLine.....	RNT2029	\$	119.00

Tools

Diesel Timing Tool Kit

Diesel 2.5 NA, 2.5 Turbo, 200 Tdi & 300 Tdi engines.
For engine & injection pump timing adjustments.
RNT2029 \$ 119.00



Prop Shaft Socket Tool

Series, Defender & Discovery
For easy front or rear prop shaft removal.



RNT141 \$ 36.50

Transmission Main Shaft Nut Tool

Series II, IIA, III, 2.25 & 2.26 Litre



RNT0002 \$ 49.95

Hub Nut Tool

Series, Defender, Discovery I & Range Rover Classic
2 1/6" for servicing the adjuster and lock nuts on your Land Rover's hub bearings.



RNF406 \$ 14.39

Drain Plug

Oil drain plug tool for slotted type drain plugs on Series differentials and gearboxes.



RNT0003 \$ 24.95

Torx Drive Bit

#40 ZF Automatic transmission oil plugs.
#55 R380 oil plugs.



RNT0009 \$ 12.99

RNT0010 \$ 10.99

Heavy Duty Lug Wrenches

Series, Defender with steel wheels.

Early Series IIA with 15/16" lugnuts LUG15-16 \$ 19.95
Late Series IIA, III, Defender 90, 110 with 1 1/16" lugnuts LUG1116 \$ 18.85



Clutch Alignment Tool

Series II, IIA, III, 2.25 & 2.26 Litre TLS33 \$ 5.45
Defender, Discovery V8 TLS33D \$ 5.45
Defender 300 Tdi TLS300 \$ 5.45

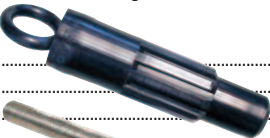

Tool Bar

For use with RNT002, RNF406 & RNT003 RNT0004 \$ 6.18

Hand Crank for Engine Starting

Series II, IIA, 4 & 6 Cylinder
Also works great as a service tool for points replacement and valve adjustment.

PLA951 \$ 34.50

Viscous Fan Tool

Defender, Discovery 1994-2004 & Range Rover 1987-2002.

Specialized tool for easy fan removal. 32mm & 36mm RNT140 \$ 16.90

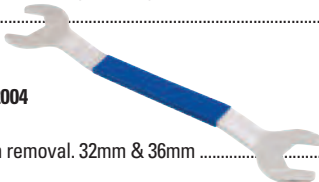

Bullet End Crimping Tool

RNT0085 \$ 83.48



Torque Angle Gauge 1/2" Drive

RNT0012 \$ 24.95



3-Piece HD Ratchet Crimping Tool

RNT0087 \$ 56.95



Genuine Workshop Manuals

Series II, IIA Workshop Manual	RNC818	\$ 99.50
Series IIA Parts Manual	RNF256	\$ 54.95
Series IIA, Owners Manual	RNE250	\$ 24.95
Series III 1972-85, Workshop Manual	RNC816	\$ 59.95
Series III Parts Manual	RNF257	\$ 61.43
Series IIA, III, 109 V8 Parts Manual Optional Equipment	RNF258	\$ 40.95
Series III, 109 V8 Owners Manual Supplement	RNI186	\$ 34.95
Defender 90/110 300 TDI 1996-'98, Workshop Manual	RNN220	\$ 99.95
Defender 90/110 TD5 1999-'05, Workshop Manual	RNI188	\$ 119.95
Defender 1993-95, Rest of World, Workshop Manual	RNS723	\$ 119.95
Defender 1993-95, Workshop Manual w/Binder	RWM905	\$ 79.95
Defender 90 1997, Workshop Manual w/Binder	RWM907	\$ 103.95
Defender 110 up to Aug 1986, Parts Manual	RNS952	\$ 59.95
Discovery I, 1994-98, Workshop Manual	RNS847	\$ 119.95
Discovery II, Workshop Manual Insert 2 vol	RNN219	\$ 128.90
Discovery II, 1999- Workshop Manual 2 vol w/Binder	RWM992	\$ 187.95
Discovery II, 1999-02, Parts Catalog	RNS945	\$ 59.95
Range Rover Classic 1992-94, Workshop Manual w/Binder	RWM924	\$ 152.25
Range Rover Classic 1986-91, Parts Manual Insert	RNS953	\$ 81.22
Range Rover Classic 1995 Manual ETM RHD	RNS947	\$ 158.86
Range Rover Classic 1987-92, Parts Manual Insert	RNS954	\$ 79.95

Hylomar Gasket Sealer

The official sealer used by Land Rover during assembly, 3.5 oz (100g)
RNA681 \$ 10.95



ARB Tire Repair Kit

10000010 \$ 42.95



Premium Tool Roll Limited Edition

Constructed with premium deep weave canvas and covered with stain resistant Land Rover logo woven nylon to create an exceptional quality tool roll for the Land Rover enthusiast. Premium details include protective interior flap, full width pocket for smaller tools like sockets and brass plated closure hardware. Made in the UK constructed 100% with Land Rover materials. RNTR03 \$ 69.95



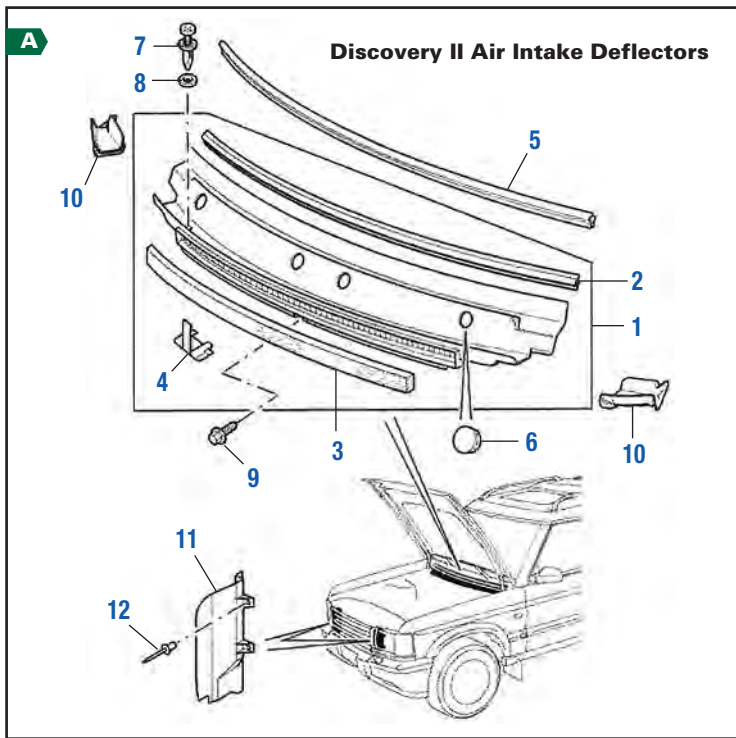

A Discovery II Air Intake Deflectors

1. PLENUM FRESH AIR INTAKE DISCOVERY II	RNN973	\$ 259.95
2. SEAL-SCUTTLE FINISHER DISCOVERY II	RNS286	\$ POA
3. FOAM FRESH AIR INTAKE DISCOVERY II	RNH871	\$ 25.95
4. SPRING CLIP FRESH AIR IN DISCOVERY II	RNS287	\$ 2.69
5. SEAL AIR INTAKE PLENUM DII.....	RNS288	\$ 124.93
6. BLANKING PLUG BULKHEAD DISCOVERY II.....	RNS289	\$ 3.95
7. SCRIVET 8 X 22MM.....	RNS290	\$ 5.11
8. WASHER NYLON FRESH AIR INTAKE DII.....	RNS291	\$ 1.23
9. SCREW FRESH AIR INTAKE PLENUM DISCOVERY II.....	RNS292	\$ 4.34
10. MOULDING PLENUM RH AIR DISCOVERY II	RNS293	\$ 19.95
MOULDING PLENUM LH AIR DISCOVERY II	RNS294	\$ 21.14
11. WIND DEFLECTOR RH DISCOVERY II	RNS295	\$ 38.94
WIND DEFLECTOR RH DISCOVERY II	RNS296	\$ 31.39
WIND DEFLECTOR LH DISCOVERY II.....	RNS297	\$ 44.59
WIND DEFLECTOR LH DISCOVERY II.....	RNS298	\$ 47.74
12. POP RIVET.....	RNC690	\$ 1.25
POP RIVET 3/16"X 7/16"	PLC690	\$ 0.45

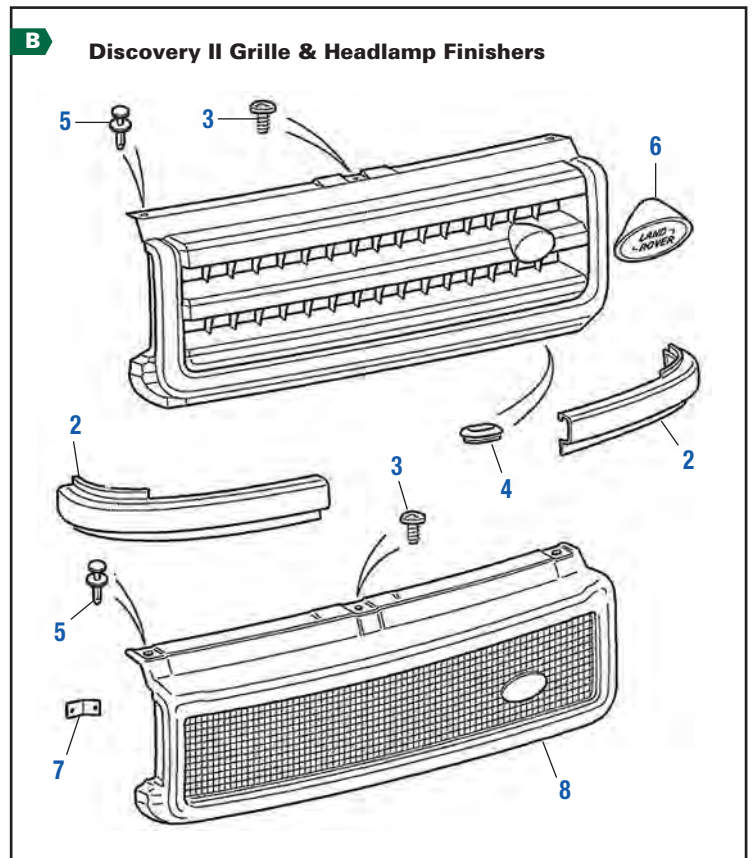

B Discovery II Grille & Headlamp Finishers

1. FRONT GRILLE BLACK '99-'02	RNN753	\$ 224.95
FRONT GRILLE BLACK '03-'04.....	RNN755	\$ 239.95
2. HEADLAMP FINISHER BLACK PRIMER RH '99-'0	RNL427	\$ 43.67
HEADLAMP FINISHER BLACK PRIMER LH '99-'0	RNL428	\$ 43.67
HEADLAMP FINISHER PRIMER RH '03-'04	RNI225	\$ 29.17
HEADLAMP FINISHER PRIMER LH '03-04.....	RNI226	\$ 29.18
3. FLANGE HEAD SCREW (QTY 3 REQUIRED)	RNI206	\$ 0.65
4. GROMMET (QTY 4 REQUIRED).....	RNN756	\$ 3.95
5. SCRIVET (QTY 3 REQUIRED)	RNN757	\$ 2.39
6. NAME PLATE.....	RNF771	\$ 24.95
7. BRACKET- GRILLE PANEL DII	RNN758	\$ 17.70
8. FRONT GRILLE PRIMER GREY FROM #XA218093.....	RNN754	\$ 902.39

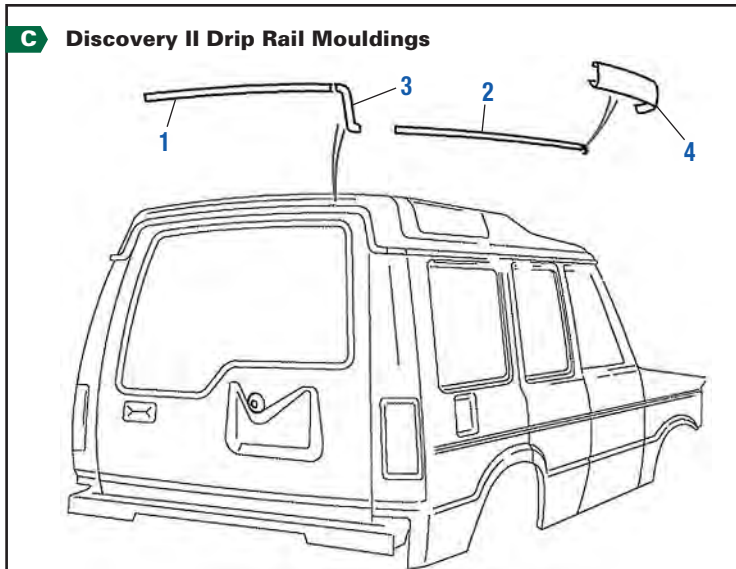

C Discovery II Drip Rail Mouldings

1. DRIP RAIL CENTER REAR DISCOVERY II	RNQ920	\$ 73.84
2. FINISHER RH DRIP RAIL DISCOVERY II	RNQ922	\$ 98.95
FINISHER LH DRIP RAIL DISCOVERY II	RNQ921	\$ 115.95
3. FINISHER RHR DRIP RAIL DII	RNQ923	\$ 91.77
FINISHER LHR DRIP RAIL DII.....	RNQ924	\$ POA
4. FINISHER ROOF DRIP RAIL FRNT LH DISCO II.....	RNQ926	\$ 89.95
FINISHER ROOF DRIP RAIL FRNT RH DISCO II.....	RNQ925	\$ POA



MIRROR ASSEMBLY W/POWER, DISCOVERY II
 RH CONVEX, DII RNS768 \$ 239.95
 LH FLAT, DII RNS767 \$ 267.63

RNS767

MIRROR GLASS DISCOVERY I, II
 RH CONVEX, DII RNS459 \$ 69.95
 LH FLAT, DI RNS458 \$ 52.29

RNS458

Window Regulators & Window Motors



RNH541



Learn how your Land Rover works—do it yourself and save!



Download the Rovers Magazine Technical Article PDF on Replacing Window Regulators.

Range Rover

Classic 1995 from SA658967

	Regulator	Motor
RH Front, Genuine	RNH542 \$ 229.95	RNH949 \$ 259.95
RH Front, ProLine	PLH542 \$ 69.00	PLH949 \$ 78.50
LH Front, Genuine	RNH541 \$ 215.95	RNH951 \$ 259.95
LH Front, ProLine	PLH541 \$ 69.00	PLH951 \$ 79.99
RH Rear, Genuine	RNH945 \$ 179.95	RNH951 \$ 259.95
RH Rear, ProLine	PLH945 \$ 69.80	PLH951 \$ 79.99
LH Rear, Genuine	RNH947 \$ 179.95	RNH949 \$ 259.95
LH Rear, ProLine	PLH947 \$ 69.80	PLH949 \$ 78.50

Range Rover

Classic SWB up to SA658966

RH Front, Genuine	RNH539 \$ POA	RNI317 \$ POA
RH Front, ProLine	PLH539 \$ 89.50	PLI317 \$ 129.00
LH Front, Genuine	RNH540 \$ 199.95	RNI318 \$ 599.95
LH Front, ProLine	PLH540 \$ 89.50	
RH Rear, Genuine	RNH944 \$ POA	RNI323 \$ POA
LH Rear, Genuine	RNH946 \$ 116.58	RNI322 \$ POA

Range Rover P38A

RH Front, Genuine	RNI752 \$ 395.58	RNL753 \$ 284.52
RH Front, ProLine	PLI752 \$ 99.95	PLL753 \$ 78.99
LH Front, Genuine	RNI751 \$ 395.58	RNL767 \$ 301.97
LH Front, ProLine	PLI751 \$ 99.95	PLL767 \$ 78.99

Range Rover P38A

RH Rear, Genuine	RNN299 \$ 473.28	RNL753 \$ 284.52
RH Rear, ProLine		PLL753 \$ 78.99
LH Rear, Genuine	RNN300 \$ 467.82	RNL767 \$ 301.97
LH Rear, ProLine		PLL767 \$ 78.99

Range Rover L322 (complete unit with regulator and motor)

RH Rear, Genuine	RNQ790	Included	\$ 209.95
LH Rear, Genuine	RNQ791	Included	\$ 209.95

Discovery II

ACE & Power Steering Fluid

Discovery II
ACE & Power Steering Fluid,
1 Litre RNN517 \$ 34.95



Genuine Parts



Tie Rod Ends

Discovery I 1994-'99

RH Thread, Includes hardware, Genuine	RNS069	\$ 59.95
RH Thread, Includes hardware, ProLine	PLS069	\$ 26.50
LH Thread, Includes hardware, Genuine	RNS070	\$ 69.95
LH Thread, Includes hardware, ProLine	PLS070	\$ 26.50

Discovery II 1999-'04

Drag Link Assembly LHD, Genuine	RNH138	\$ 229.95
Track Rod Assembly, Genuine	RNH072	\$ 219.95
Ball Joint Track and Drag, Genuine	RNH139	\$ 69.95
Nyloc Nut, 12mm, Genuine	RND879	\$ 3.95

Regulator

Discovery I up to SA137189

RH Front, Genuine	RNH539	\$ POA
RH Front, ProLine	PLH539	\$ 89.50
LH Front, Genuine	RNH540	\$ 199.95
LH Front, ProLine	PLH540	\$ 89.50
RH Rear, Genuine	RNH944	\$ POA
LH Rear, Genuine	RNH946	\$ 116.58

Discovery I from SA137190

RH Front, Genuine	RNH542	\$ 229.95
RH Front, ProLine	PLH542	\$ 69.00
LH Front, Genuine	RNH541	\$ 215.95
LH Front, ProLine	PLH541	\$ 69.00
RH Rear, Genuine	RNH945	\$ 179.95
RH Rear, ProLine	PLH945	\$ 69.80
LH Rear, Genuine	RNH947	\$ 179.95
LH Rear, ProLine	PLH947	\$ 69.80

Discovery II

RH Front, Genuine	RNH542	\$ 229.95
RH Front, ProLine	PLH542	\$ 69.00
LH Front, Genuine	RNH541	\$ 215.95
LH Front, ProLine	PLH541	\$ 69.00

Discovery II up to 1A719661

RH Rear, Genuine	RNI315	\$ 282.59
RH Rear, ProLine	PLI315	\$ 69.50
LH Rear, Genuine	RNI316	\$ 285.67
LH Rear, ProLine	PLI316	\$ 69.50

Discovery II from 1A719662

RH Rear, Genuine	RNI315	\$ 282.59
RH Rear, ProLine	PLI315	\$ 69.50
LH Rear, Genuine	RNI316	\$ 285.67
LH Rear, ProLine	PLI316	\$ 69.50

Defender

Manual Windows (regulator only)

RH Front, Genuine, 1987-2006	RNQ788	\$ 152.61	—	—
RH Front, Genuine, 2007 on	RNL689	\$ 197.83	—	—
LH Front, Genuine, 2007 on	RNL690	\$ 197.83	—	—
LH Front, Genuine, 2007 on	PLL690	\$ 79.95	—	—

Electric Windows (complete unit with regulator and motor)

RH Front, Genuine	RNL761	Included	\$ 324.85
LH Front, Genuine	RNL762	Included	\$ 324.85



Rock Sliders, Bumperettes

Series II, IIA, III with Jack Points, Galvanized	RNA1011	\$ 399.00
Series III 109" Rock Sliders Pair	RNA1109S3	\$ 459.64
Defender 90 , Mantec with Jack Points, Black.....	RNA1001	\$ 399.00
Defender 90, Terrafrima Rock Slider Set w/Tree Bars, Black.....	TF801	\$ 429.00
Defender 90, Rovers North Rock Slider Set with Tree Rail, Black.....	RNA5608	\$ 399.00
Defender 90, Rovers North Rear Bumperette Set, Black.....	RNA0126	\$ 299.00
Defender 110 , Mantec with Jack Points, Black.....	RNA1005A	\$ 499.00
Defender 110, Terrafrima Rock Slider Set w/Tree Bars, Black.....	TF810	\$ 479.00
Defender 110, Rovers North Rock Slider w/Tree Bars, Black.....	RNA5609	\$ 459.00
Defender 110, Rovers North Rear Bumperette Set, Black.....	RNA0201	\$ 339.00
Discovery I, Range Rover Classic 100" , with Jack Points, Black.....	RNA2014	\$ 579.00
Discovery I, Terrafrima Rock Slider Set w/Tree Bars, Black.....	TF807	\$ 699.00
Discovery II , Terrafrima Rock Slider Set, Black.....	RNA1117	\$ 599.00
Discovery II, Terrafrima Rock Sliders w/Tree Bars, Black.....	TF809	\$ 699.00



Next Generation Differential Guards.

Feature a wraparound hot dipped galvanized formed 3mm steel plate. Designed to withstand off-road impact and to skid over obstacles. Easy to install and easy to remove for complete service access. Includes mounting hardware. Made in the UK.

Front Differential Guards

Series III, Defender 1983-2014, Range Rover Classic 1971-1995, Discovery I-II 1993-2004.RNA0100 \$ 125.00

Rear Differential Guards

Series III, Defender 90 ONLY 1985-2001, Range Rover Classic 1971-1995, Discovery I-II 1993-2004.RNA0101 \$ 125.00
 PUMA Style 110, 130, 2001-2015 and Defender 110XD TUM.....RNA0103 \$ 119.95
 Differential Guard Salisbury, 109 & 110 1972 on.....RNA0102 \$ 89.95



Terrafrima Front Bumper

A stylish close fit off-road bumper for enhanced approach angle. Features wrap around edges with a special washer fluid reservoir protection plate. A direct replacement for 2003 -2004 stock bumper. Requires removing the bottom inch of plastic center grill on 1999-2002 models. Made from 5mm steel with black powder coat finish. Uses popular Warn 9 mount pattern to fit most electric winches. Will require removing a section of center grill to accommodate winch. Includes mounting hardware. Made in the UK by Terrafrima. For swivel recovery shackles use TFSRP.

Terrafrima Front Winch Bumper, includes mounting hardware. TF009A \$ 699.00

Flip Up License Plate Holder for Roller Fairlead

Designed to bolt into the top of Warn style roller fairleads. Flips up and out of the way for winching. 16 gauge construction. Black powder coat finish. Includes hardware for mounting license plate. Made in the USA by Tuffy. **RNA189 \$ 18.95**



Rear Heavy Duty Bumper - Discovery II, Rear heavy duty bumper. Black powder coat finish. Made in the UK.RNA196 \$ 499.00

Terrafrima Heavy Duty Rear Bumper, includes mounting hardware. For swivel recovery shackles use TFSRP. Made in the UKTF090A \$ 699.00

Swivel Recovery Shackle fits front bumpers TF009A, RNA195, RNA194, and rear bumper TF090A.....TFSRP \$ 79.00 ea

Access Ladder Rear, Discovery I, II, GenuineRNA661 \$ 159.95

Access Ladder Rear, Discovery I, II, Powder coated over zinc plating, superior corrosion resistance, ProLine.....PLA661 \$ 99.98



Extreme Suspension Gear for Off-Road use

Fits Defender, Discovery I, Range Rover Classic

Adjustable Heavy Duty Panhard Rod

Discovery I, RRC, Defender, ProLine PLS024A \$ 129.00

Discovery II '99-2002 TF254 \$ 199.99

Discovery II '03-2004 TF256 \$ 199.99



RNA5612

PLS024A

Solid Steel Heavy Duty Steering Rod Sets

Complete kit for upgrading both front axle steering tubes for extreme duty. Includes zinc coated solid steel track rod, drag link and replaceable tie rod ends with HD lock nuts instead of clamps.

Series II-III 88, 109 all models 1959-1984. RNA5612 \$ 199.50

Defender all models.....RNE448HDS \$ 199.50

Discovery I, RRC, ProLine 3 rod end.....RNA562 \$ 199.50

Discovery II Powder coated over zinc coated steel, ProLine.....RNA5611 \$ 219.99



RNA5611

RNA562

Castor Correction Bushing Kit

For front radius arms.

An inexpensive way to restore positive caster angle to a vehicle lift with 2-3 inches. Set of 4.

CALR2 \$ 129.95



Corrected Front Radius Arms for Lifted Land Rover Vehicles

Realigns caster angle for correct front axle steering and handling geometry. Sold as pairs.

Front Radius Arms

3 Degrees (2-4" lift) pair

TF508 \$ 459.00

6 Degree (4-6" lift) pair

RNA0747 \$ 628.95

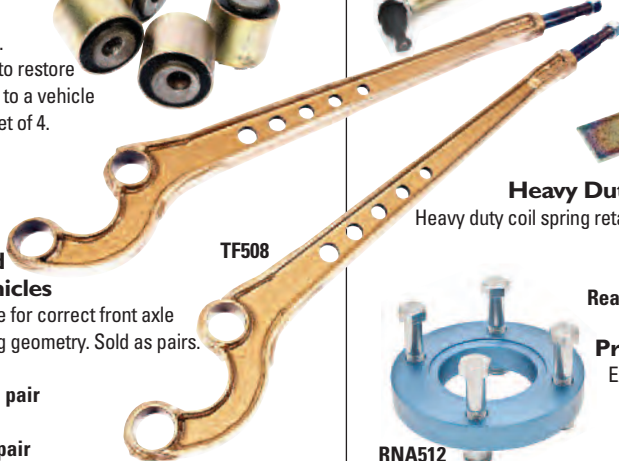

TF508

Heavy Duty Spring Retainers

Heavy duty coil spring retaining plates. Sold in pairs.

Front Pair TF505 \$ 12.99

Rear Pair TF506 \$ 12.95

Rear HD D110 TF507 \$ 12.99

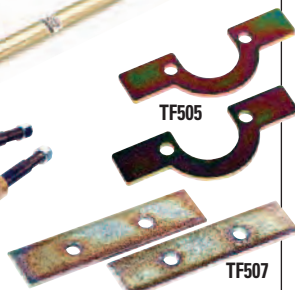

TF505

TF507

Propshaft Spacer Kit

Extends driveshaft length 15mm. Fits front or rear.

RNA512 \$ 29.95



RNA512

Heavy Duty Rear Cranked Trailing Link Set

Rear trailing link set, locates rear axles to chassis. Designed for vehicles with suspension lifts from 2 to 4 inches above stock height. Offset angle allows more movement where the trailing link meets the chassis for greater axle articulation and improved off-road performance. Set includes 2 trailing links with Ploy Flex bushings for the rear axle attachment bolts. Grey powder coat finish. Made in the UK. FITS: Defender all models 1993- 2014 Except XD, Range Rover Classic 1971-1995 with coil spring suspension, Discovery I 1993-1999 RNA5610 \$ 198.00

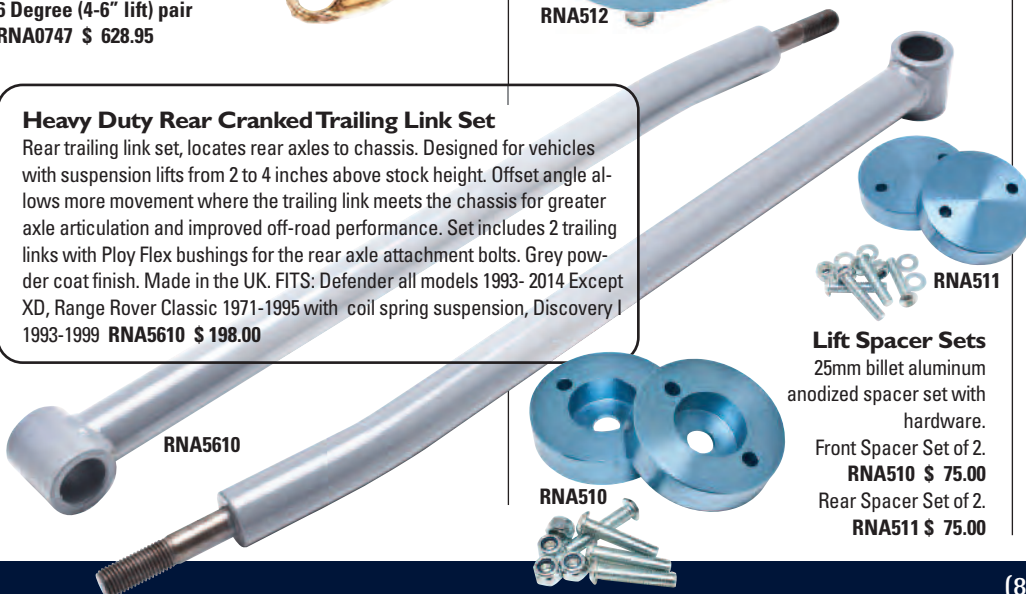

RNA5610

RNA510

RNA511

Lift Spacer Sets

25mm billet aluminum anodized spacer set with hardware.

Front Spacer Set of 2. RNA510 \$ 75.00

Rear Spacer Set of 2. RNA511 \$ 75.00



TF504

TF534

RNA198G

Heavy Duty Shock Tower Sets

Available in standard 10" height or lowered 8" height to allow more suspension drop.

Defender, Discovery I, RRC

10" HD Shock Tower SetTF504 \$ 139.95

8" HD Shock Tower Set, Terraforma.....TF503 \$ 139.95

Discovery II

10" HD Shock Tower Set, Terraforma...TF534 \$ 189.00

10" HD Performance Shock Tower Set, Galvanized, ProLine.....RNA198G \$ 185.00

Heavy Duty Securing Rings for Front Towers Fits all coil sprung models.

Sold as a pair with nyloc nuts. TF502 \$ 27.95



TF502

Coil Spring Dislocation Cones

When longer than standard front shocks are fitted the coil spring can move around becoming dislocated on full suspension drop out, sometimes failing to relocate correctly when the suspension compresses again. Fitting dislocation cones in conjunction with spring retaining plates TF505 will ensure the spring re-seats correctly every time.

Front Dislocation Cones TF501 \$ 89.00

Rear Dislocation Cones TF510 \$ 89.00



TF510

ProLine 2 Inch Lift Spacer Kit

Raise your coil sprung vehicle by 2 inches, using our welded steel Lift Spacer Kit. Easy to install, for that DIY person, no special tools are required. Fits between axle and spring plate. Set of 4 (2 front and 2 rear). Does not fit Discovery II's. Fits: Range Rover Classic, Defender 90/110, Discovery I RNA5102 \$ 99.95



Shocks for Land Rover

Series IIA, III, Defender, Discovery I & II, Range Rover Classic, P38A



NEW Front Struts for 2003-'09 Range Rover L322

Refurbish your 2003-'09 Range Rover L322 air suspension system with completely new OEM front struts.

2003-'06 RH, Genuine.....	RNI375	\$1234.15
2003-'06 RH, ProLine.....	PLI375	\$ 589.00
2003-'06 LH, Genuine.....	RNI373	\$1234.15
2003-'06 LH, ProLine.....	PLI373	\$ 589.00
2007-'09 RH, ProLine.....	PLN031	\$ 589.00
2007-'09 LH, ProLine.....	PLJ700	\$ 589.00



ES9000 Standard Length Shock Kits

These Pro Comp ES9000 dual action nitrogen gas shocks incorporate a twin-tube cellular gas design that prevents foaming and reduces shock fade to improve the ride quality of leaf spring suspension. Shock sets include bushings and optional poly vinyl dust boots in black.

Kits sold as set of four shocks.

Series II, IIA, III

Front & Rear shock kit 109".....	PCS3109	\$ 209.00
Front & Rear shock kit 88".....	PCS3088	\$ 199.00
Discovery I, Range Rover Classic, Defender		
Front & Rear Shock Kit.....	PCS9000	\$ 199.00



ES9000 + 2 inch Raised Shock Kits

Nitrogen gas charged shocks with two inches of extra travel. (Designed for off-road performance for vehicles with raised suspension of two inches or less). Excellent all around ride quality and handling. Shock sets include bushings and optional poly vinyl dust boots in black.

Kits sold as set of four shocks.

Discovery I 1989-1999

Front & Rear Shock Kit.....	PCS9030	\$ 199.00
Range Rover Classic 1987-1993 with coil suspension		
Front & Rear Shock Kit.....	PCS9050	\$ 199.00
Defender 1983-1998		
Front & Rear Shock Kit.....	PCS9020	\$ 199.00



Bilstein Standard Length Shocks & Steering Dampers

The world leader in gas-pressurized shock absorber technology. Bilstein utilizes a one piece seamless mono-tube design filled with oil and nitrogen gas in a pressurized, sealed compartment. We recommend for use with Land Rover Genuine Standard or Heavy Duty springs in normally equipped vehicles. Not recommended for heavily laden vehicles with oversize tires. Lifetime warranty.

Kits sold as set of four shocks.

Defender	RNA243-4	\$ 439.00
Set of four shocks & damper.....	RNA243-5D	\$ 539.00
Discovery I 1994-1999	RNA243-6	\$ 439.00
Set of four shocks & damper.....	RNA243-7	\$ 539.00
Discovery II 1999-2004	RNA6046-7	\$ 599.00
Range Rover Classic w/coil springs 1987-1995		
Set of four shocks.....	RNA243-4	\$ 439.00
Set of four shocks & damper.....	RNA243-5	\$ 539.00
Range Rover Classic LWB w/ air suspension		
Set of four shocks.....	RNA2152-3	\$ 429.00
Range Rover P38A 1999-2002	RNA2214-5	\$ 439.00

Steering Dampers

Defender.....	RNA235	\$ 139.95
Discovery I, RR Classic.....	RNA245	\$ 139.95
Discovery II.....	RNA246	\$ 139.95

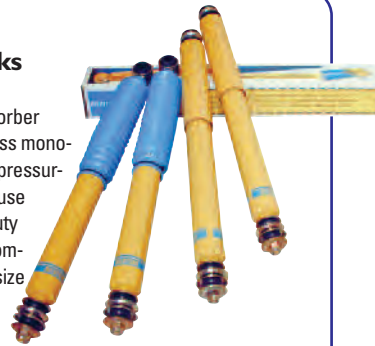

Big Bore Expedition Shocks

Developed specifically for fully laden working Land Rovers. **Features include:** 76mm body, twin tube design • 50mm internal bore and piston • 20mm double chromed shaft • High temperature oil fluid • 2.5mm outer shock tube wall thickness • 14mm mounting pins. Superior all around performance.

Kits sold as set of four shocks.

Discovery I 1989-1999

Range Rover Classic 1987-1993 with coil suspension

Defender

Front and rear shock kit.....	RNK721	\$ 359.00
-------------------------------	---------------	------------------

Steering Dampers

Discovery I 1989-1999

Range Rover Classic 1987-1993

with coil suspension.....	RNA811	\$ 54.50
---------------------------	---------------	-----------------

Defender.....	RNA832	\$ 59.95
---------------	---------------	-----------------

Return to Center Damper.....	TF835	\$ 119.95
------------------------------	--------------	------------------



Pro Sport + 2 inch Shocks

Exclusively designed for off-roading Land Rovers. This is a true +2" longer than standard shock. The advantages when driving off-road are remarkable as these shocks are built with hardcore use in mind. Fitted with velocity sensitive valving means the shock will automatically adjust its internal damping to suit driving conditions, the harder you punish them the better they work. On the drive home you'll really notice the superior ride quality and handling.

Kits sold as set of four shocks.

Discovery I 1989-1999

Range Rover Classic 1987-1993 w/coil susp.

Defender

Front and rear shock kit.....	RNK722	\$ 329.00
-------------------------------	---------------	------------------

Discovery II 1999-2004

Front & Rear Shock Kit.....	RNK728	\$ 239.00
-----------------------------	---------------	------------------

Steering Dampers

Discovery I '89-1999, RRC '87-'95.....	RNA811	\$ 54.50
--	---------------	-----------------

Discovery II.....	RNA802	\$ 53.95
-------------------	---------------	-----------------

Defender.....	RNA832	\$ 59.95
---------------	---------------	-----------------

Return to Center Damper.....	TF835	\$ 119.95
------------------------------	--------------	------------------



OFFROAD RACE PROGRAM

Bryce Menzies, Trophy Truck Champion

FOX REDEFINE YOUR LIMITS



NEW Fox Shock Direct Replacement Shocks

FOX direct replacement shocks deliver race-winning performance in a simple direct replacement bolt on shock. Each application has been rigorously tested by our engineers to maximize suspension travel and performance on and off the road. Direct replacement shocks are available in hundreds of applications from stock to lifted, as well as aftermarket kit replacements. **FITS: Front Defender all models, Range Rover Classic up to 1993 Except LWB, Discovery I all models.** Sold as each.

FOX SHOCK IFP FRONT 406200 \$ 209.95 ea

NEW Fox Shock for +2" Raised Suspension

Built for Land Rover models with raised suspension using plus 2 inch coil springs or spacers. Fox direct replacement shocks deliver race-winning performance in a simple direct replacement bolt on shock. Each application has been rigorously tested by our engineers to maximize suspension travel and performance on and off the road. Thoroughly perfected in brutal conditions that you will probably never experience. Fox athletes push the boundaries in competition to develop race-proven performance you can bolt onto your Land Rover. Features an adjustable remote reservoir. **FITS: Rear Defender all models, Range Rover Classic up to 1993 Except LWB, Discovery I all models.** Sold as each.

FOX SHOCK PS, IFP 0-1" LIFT FRONT.....	870425	\$ 129.95 ea
FOX SHOCK PS, IFP 0-1" LIFT REAR.....	970425	\$ 129.95 ea
FOX SHOCK PS, IFP 1.5-3.5" LIFT FRONT.....	804258	\$ 129.95 ea
FOX SHOCK PS, IFP 1.5-3.5" LIFT REAR.....	180425	\$ 129.95 ea
FOX SHOCK REMOTE RESERVOIR 2.0 SERIES		
C/D ADJUSTABLE REAR.....	216420	\$ 334.95 ea



Rear Roost Shield Kit

Protects rear shock shaft and seals from rocks kicked up by tires. The Roost Shield securely attaches to 2.0 Performance Series IFP and 2.0 Evolution Series IFP rear shocks. The kit includes a pair of rigid ABS Roost Shields and all mounting hardware. **2.0 IFP Rear Roost Shield Kit (pair) 250208 \$ 29.99 pr**

TerraFirma
Serious 4x4 Accessories

TerraFirma 2" Lift Coil Spring Selection

All TerraFirma Coil Springs have been designed to provide approximately 2" (50mm) of lift while carrying light, medium or heavy loads.

Load carrying coil springs are often progressive or variable (V) this provides a combination of comfort and load carrying in one spring.

It is worth noting that TerraFirma coil springs are sold in pairs, in many cases one spring is 10mm longer than the other, the longer spring should always be fitted to the driver's side. **Sold in pairs.**

TerraFirma Coil Springs	Light Load	Medium Load	Heavy Load
Defender 90			
Coil Spring Front, pair	TF014 \$ 129.99	TF018 \$ 149.00	TF015 \$ 139.50
Coil Spring Rear, pair	TF015 \$ 139.50	TF023V \$ 147.95	TF027V \$ 179.00
Defender 110			
Coil Spring Front, pair	TF014 \$ 129.99	TF018 \$ 149.00	TF015 \$ 139.50
Coil Spring Rear, pair	TF010 \$ 219.00	TF019 \$ 219.00	TF011 \$ 239.00
Discovery I / RR Classic			
Coil Spring Front, pair	TF014 \$ 129.99	TF018 \$ 149.00	TF015 \$ 139.50
Coil Spring Rear, pair	TF015 \$ 139.50	TF023V \$ 147.95	TF027V \$ 179.00
Discovery II (non-ACE)			
Coil Spring Front, pair		TF042 \$ 134.95	TF052 \$ 109.50
Coil Spring Rear, pair		TF023V \$ 147.95	TF027V \$ 179.00





ABOVE AND BEYOND

STAY TRUE TO YOUR LAND ROVER WITH LAND ROVER GENUINE PARTS

Land Rover Genuine Parts are designed specifically for your vehicle and come with numerous benefits that will ultimately help extend the lifespan of your Land Rover.

The advantages of Land Rover Genuine Parts:

- These parts have been designed, tested and manufactured according to Land Rover's uncompromising premium standard to ensure the superior quality and durability of every part.
- Every Land Rover Genuine Part comes with a 12-month warranty.
- With each part and component, you can have complete confidence in its fit, quality, durability and function.
- Land Rover Genuine Parts, in combination with regular vehicle maintenance, will help protect your Land Rover, providing enhanced safety and performance.



Discovery II Rear Air to Coil Spring Conversion Kit

Kit contains Genuine parts, everything for the conversion, instructions and hardware.

Discovery II, Genuine **RNK5118 \$ 319.00**



Land Rover Genuine Shocks for Discovery II



DISCOVERY II, UP TO 2002

FOR COIL SPRING w/ACE (ACTIVE CORNERING ENHANCEMENT)

FRONT, EACH.....	RND786	\$ 99.00
REAR, EACH.....	RNH069	\$ 99.00

FOR COIL SPRING w/o ACE

FRONT, EACH.....	RND785	\$ 99.00
REAR, EACH.....	RND817	\$ 133.72

FOR AIR SPRINGS w/ACE

FRONT, EACH.....	RND787	\$ 99.50
REAR, EACH.....	RND819	\$ 99.80

FOR AIR SPRINGS w/o ACE

FRONT, EACH.....	RND787	\$ 99.50
REAR, EACH.....	RND818	\$ 99.50

RND785

RND817

DISCOVERY II, 2003 ON

FRONT, EACH.....	RND787	\$ 99.50
REAR, EACH.....	RND818	\$ 99.50

Land Rover Genuine Coil Springs for Discovery II



RNH627

RND736

RKB000330

FRONT, EACH.....	RND795	\$ 169.95
REAR, EACH.....	RNH627	\$ 129.00
REAR, HEAVY DUTY.....	RNX044	\$ 142.71
ISOLATOR FOR REAR COIL SPRING.....	RND736	\$ 25.95

Land Rover Genuine Superior Performance Variable Rate Coil Spring Kits



Defender 90, Coil Spring Set of Four, HD w/winch, Genuine.....	RNK5111	\$ 459.50
Defender 90, Coil Spring Set of Four, Heavy Duty, Genuine.....	RNK5101	\$ 398.00
Defender 110, Coil Spring Set of Four, HD, Genuine.....	RNK5102	\$ 389.00
RR Classic, Coil Spring Set of Four, HD w/winch, Genuine.....	RNK5114	\$ 459.50
RR Classic, Coil Spring Set of Four, HD, Genuine.....	RNK5104	\$ 439.00
RR Classic, Coil Spring Conversion Kit for Air Suspension, Genuine.....	RNK5105	\$ 539.00
Discovery I, Coil Spring Heavy Duty, Set of Four, Genuine.....	RNK5103	\$ 439.00
Discovery I, Coil Spring Extra HD, Set of Four, Genuine.....	RNK5113	\$ 459.50
Discovery II, Coil Spring Conversion Kit Rear, Genuine.....	RNK5118	\$ 319.00



TerraFirma Pro Sport +2 inch heavy duty suspension kits

Include; 4 TerraFirma +2 inch Pro Sport shocks and 4 +2 inch springs. Great off-road, excellent on-road.

- Defender 90**, TerraFirma Pro Sport HD Suspension Kit**RNK725** \$ 559.95
- Defender 110**, TerraFirma Pro Sport HD Suspension Kit**RNK727** \$ 639.00
- Discovery I**, 1994-'99, TerraFirma Pro Sport HD Suspension Kit.....**RNK726** \$ 559.95

TerraFirma All Terrain Heavy Duty Suspension Kit. Designed for Discovery II's with extra large tires and extra accessory weight. Very good off-road, very good on-road. Includes 4 TerraFirma +2 inch All Terrain shocks and 4 +2 inch springs.

- Discovery II**, 1999-'04, TerraFirma All Terrain HD Suspension Kit.....**TF230** \$ 499.00



Discovery II

Heavy Duty Air to Coil Conversion Kit with +2" Long Travel Shocks

Plus 2 Inch Kit by TerraFirma Includes: 4 Heavy Duty Springs, 4 HD Shocks, 2 Bottom Plates w/Bolts and 2 Isolators.**TF230** \$ 499.00

PLF171



Steering Dampers

- Defender**, Steering Damper, TerraFirma**RNA832** \$ 59.95
- Defender**, Steering Damper, Genuine**RNF171** \$ 139.95
- Defender**, Steering Damper, ProLine.....**PLF171** \$ 62.95
- Defender**, Return to Center Damper, TerraFirma.....**TF835** \$ 119.95
- Discovery I, RRC, Series 88, 109, Genuine****RNS122** \$ 129.95
- Discovery I, RRC, Series 88, 109, ProLine**.....**PLS122** \$ 44.50
- Discovery I, RRC, Series 88, 109, Bilstein****RNA245** \$ 139.95
- Discovery II**, Steering Damper, Genuine**RND925** \$ 129.95
- Discovery II**, Steering Damper, ProLine**PLD925** \$ 49.99
- Discovery II**, Steering Damper, TerraFirma HD**RNA802** \$ 53.95
- Range Rover P38A**, Steering Damper, Genuine**RND924** \$ 122.57
- Range Rover P38A**, Steering Damper, TerraFirma.....**TF834** \$ 69.95

Suspension Kits



Replacement Air Springs

- DISCOVERY II**
- AIR SPRING REAR W/LEVELING, GENUINE**RND823** \$ 453.18
 - AIR SPRING REAR W/LEVELING, PROLINE**PLD823** \$ 199.95
- RANGE ROVER P38A 1995-2002**
- AIR SPRING FRONT, PROLINE.....**PLD262** \$ 159.00
 - AIR SPRING REAR, PROLINE**PLD263** \$ 159.95
- RANGE ROVER CLASSIC**
- AIR SPRING FRONT, GENUINE.....**RNS035** \$ 449.95
 - AIR SPRING FRONT, PROLINE.....**PLS035** \$ 219.95
 - AIR SPRING REAR, GENUINE.....**RNS036** \$ 429.95
 - AIR SPRING REAR, PROLINE.....**PLS036** \$ 219.95
- RANGE ROVER L322 2003-2012**
- AIR SPRING REAR AXLE-L322 RANGE ROVER FROM (V)6A233427, GENUINE**RNQ846** \$ 399.99



OME Coil Spring Kits

- Defender 90**, Extra Heavy Duty, Coil Spring Kit **OMED90SK2** \$ 399.00
- Defender 90**, Std. Heavy Duty, Coil Spring Kit **OMED90SK1** \$ 399.00
- Defender 110** Regular Standard Heavy Duty, Coil Spring Kit . . **OMED110RSK1** \$ 399.00
- Defender 110 SW** Extra Heavy Duty, Coil Spring Kit **OMED110SK2** \$ 399.00
- Defender 110 SW**, Std. Heavy Duty, Coil Spring Kit **OMED110SK1** \$ 389.00
- RR Classic**, Coil Spring Air Suspension Conversion Kit, OME . **RNK5105A** \$ 499.00

Old Man Emu Heavy Duty Springs & Shock Kits

Ideal for owners using oversize tires combined with heavy duty bumper/winch combinations and extra vehicle equipment. Designed for heavy duty off-road use. Will raise vehicle approximately 1 inch. Great off-road, fair on-road. Includes 4 OME Nitro Charger Sport Shocks & 4 OME springs. Imported from Australia. Standard Length.



- Defender 90**, Standard Duty**OMED90K1** \$ 799.00
- Defender 90**, Heavy Duty**OMED90K2** \$ 799.00
- Defender 110** Station Wagon, Standard Duty.....**OMED110K1** \$ 799.00
- Defender 110** Station Wagon, Heavy Duty**OMED110K2** \$ 829.00
- Defender Pick Up or Hardtop**, Standard Duty**OMED110RK1** \$ 799.00
- Defender Pick Up or Hardtop**, Heavy Duty.....**OMED110RK2** \$ 799.00
- Discovery I** 1994 - 1999, Standard**OMEDS1K1** \$ 799.00
- Discovery I** 1994 - 1999, Heavy Duty**OMEDS1K2** \$ 799.00
- Discovery II** 1999-2004, Standard.....**OMEDS2K1** \$ 829.00
- Discovery II** 1999-2004, Heavy Duty**OMEDS2K2** \$ 849.00
- Range Rover Classic** 1987-1993 Coil spring, Standard**OMERRK1** \$ 799.00
- Range Rover Classic** 1987-1993 Coil spring, Heavy Duty**OMERRK2** \$ 799.00

Steering Dampers

- Defender**.....**OMESD32** \$ 94.50
- Discovery I**, Range Rover Classic.....**OMESD11** \$ 98.00
- Discovery II****OMESD02** \$ 96.50

Genuine Shock & Spring Kits

The first comment we receive from guests who test drive a new Defender is about how well it rides and handles. We got so many requests from owners desiring to improve their suspension to the level of a new Defender that we started stocking the latest and greatest Land Rover shocks. Land Rover Suspension components feature superior performance variable rate coil springs and Genuine shocks feature the latest nitrogen gas pressurized valving technology for overall superior suspension performance. So if you have had enough of aftermarket replacement suspension kits and long for something better, you won't be disappointed with Genuine Land Rover parts. Each kit includes four Genuine coil springs and four Genuine shocks for a complete replacement matched set, shock mounting bushings and hardware included.

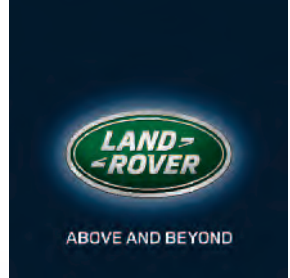

Genuine kit shown above

GENUINE LAND ROVER DEFENDER SHOCKS

Shock Absorber Front 90/110/130.....RNJ729	\$ 119.95 ea
Shock Absorber Rear 90.....RNJ722	\$ 139.95 ea
Shock Absorber Rear 110/130.....RNJ723	\$ 129.95 ea

Shock Kit Defender 90 (includes 2 front, 2 rear shocks, 1983-2015).....RNK731	\$ 499.95
Shock Kit Defender 110/130 (includes 2 front, 2 rear shocks, 1983-2015).....RNK732	\$ 479.95



Defender 110, 130 Rear Heavy Duty Inner Coil Spring Kit

Update your Defender 110 or 130 to the ultimate heavy duty rear suspension. This inner coil kit inserts into your existing heavy duty rear springs. Improves handling on-road and increases load capacity without the harsh ride. **Kit contains two rear inner coils, upper and lower retainers.** Genuine parts. Fits Defender 110, 130 only. **RNK5119 \$ 499.00**

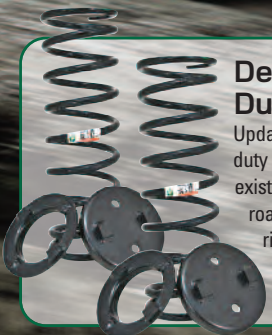

GENUINE LAND ROVER SHOCK AND SPRING KITS

DEFENDER 90, Standard.....RNK5300	\$ 984.95
DEFENDER 90, Heavy Duty.....RNK5301	\$ 984.95
DEFENDER 110, Standard.....RNK5302	\$ 889.95
DEFENDER 110, Heavy Duty.....RNK5303	\$ 899.95



Planning on towing with your Land Rover?

Perfect for towing or recovery, class III receiver hitches bolt onto the rear frame member. Can be incorporated with pintel style hitch. Includes mounting hardware. We offer receiver hitch kits to fit most Land Rover models and are Class III rated.

Receiver Hitch, Defender 1984-1998.....	RNH110	\$ 249.00
Receiver Hitch, Defender 1999 -2013.....	RNA091	\$ 279.95
Receiver Hitch, Series IIA, III Standard Chassis.....	RNA084	\$ 229.95
Receiver Hitch, Front Mount Defender.....	RNA085	\$ 279.00
Receiver Hitch, Series IIA, III Military Chassis.....	RNA086	\$ 289.95
Receiver Hitch, Series IIA, III 109" S.V.....	RNA087	\$ 229.95
Bracket Tow Hitch, Range Rover P38A.....	RNH349	\$ 150.59
Receiver Hitch Plug, "Land Rover".....	RNN397	\$ 17.95
Hitch Pin, 5/8" with clip.....	RNE231	\$ 4.40
Receiver Hitch Adaptor, Tow Jaw.....	RNA082	\$ 64.95
Tow Jaw Assembly, 7,700 lb Camel Trophy Style.....	RNF408	\$ 89.50
Shackle Mount, 2" Receiver with Hitch Pin.....	RNA1022	\$ 49.98
Lift Ring Front Bumper, Series IIA & III, Genuine.....	RNE426	\$ 69.95
Lifting Towing Ring Front Bumper, Series II-III, ProLine.....	PLN959	\$ 29.99
Front Lifting Ring Set, Series II-III, ProLine (front pair, hot dipped galvanized finish, includes all hardware).....	PLK611	\$ 84.95

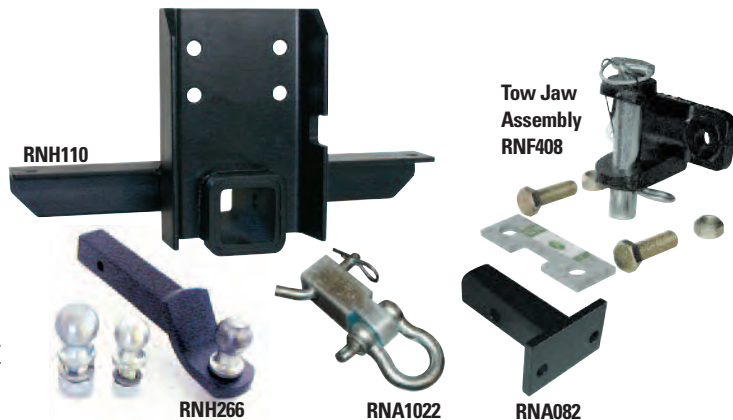

Land Rover Trailer Hitch Kits

Kit includes tow bar, 1 7/8" ball, 2" ball, ball cover, locking hitch pin and 2 safety chains.

Trailer Hitch Kit, Discovery I, II, Range Rover Classic, Genuine.....RNH266 \$ 199.00

Trailer Wiring Harness Kits

Our Genuine Trailer Wiring and Hitch Kits will get the job done. Includes: converter box, receptacle, 4-prong receptacle and all necessary wiring and hardware.

Trailer Wiring Harness, Discovery II, Genuine.....	RND241	\$ 379.95
Trailer Wiring Harness, Range Rover P38A, Genuine.....	RND170	\$ 521.51
Trailer Wiring Harness, 7-4 Pin Adapter, Genuine.....	RNS557	\$ 59.29
Plug 7 Pin Trailer Lamps.....	RNQ614	\$ 25.80



Range Rover L322 Headlamps

1. HEADLAMP ASSY LHF LHD L322 W/XENON BULB.....	RNI372	\$1311.61
HEADLAMP ASSY LH L322 FROM 4A159401.....	RNJ927	\$1019.91
2. LAMP ASSEMBLY LH FRONT FOG.....	RNI201	\$ 139.95
LAMP ASSEMBLY RH FRONT FOG.....	RNH785	\$ 139.95

Side Marker Lamps

Defender, Discovery, Range Rover P38A, LR2, LR3, L322

3. FRONT DEFENDER 93+94, ProLine.....	PLC848	\$ 14.65
REAR DEFENDER 93+, ProLine.....	PLC849	\$ 14.65
4. LHF DISCOVERY/DEFENDER, ProLine.....	PLE754	\$ 12.95
RHF DISCOVERY/DEFENDER, ProLine.....	PLE763	\$ 9.95
5. LH REAR NAS DEFENDER 90, ProLine.....	PLE757	\$ 29.95
RH REAR NAS DEF 90 '95, Genuine.....	RNE773	\$ 49.95
LH REAR NAS DEF 90 '95+'97, Genuine.....	RNE757	\$ 29.95
6. DEFENDER & FREELANDER, Genuine.....	RNI415	\$ 42.96
7. CLEAR SIDE MARKER LAMP SET DISCOVERY I, Genuine.....	RNK9922	\$ 69.88
8. FRONT WING DEFENDER NON-NAS, Genuine.....	RNL134	\$ 19.62
9. DEFENDER, DISCOVERY, P38A, ProLine.....	PLE810	\$ 5.65
DEFENDER, DISCOVERY, P38A, Genuine.....	RNE810	\$ 34.95
10. FRONT SIDE MARKER LAMP SET DISCOVERY I, Genuine.....	RNL353	\$ 62.73
11. RHR w/SIDE MARKER LR3, Genuine.....	RNQ650	\$ 334.56
LAMP ASSY LHR w/SIDE MARKER LR3, Genuine.....	RNQ651	\$ 334.56
12. LAMP ASSY FRT SIDE MARKER L322 2004+, Genuine.....	RNI383	\$ 53.14
13. LAMP ASSY LHF SIDE FLASHER - L322, Genuine.....	RNQ652	\$ 159.95
LAMP ASSY RHF INDICATOR L322 LHD, Genuine.....	RNQ653	\$ 150.34
14. HARNESS SIDE MARKER LAMP DEF 95MY>, ProLine.....	PLE803	\$ 29.95
BULB 12V 3W SIDE MARKER, Genuine.....	RNI222	\$ 1.95

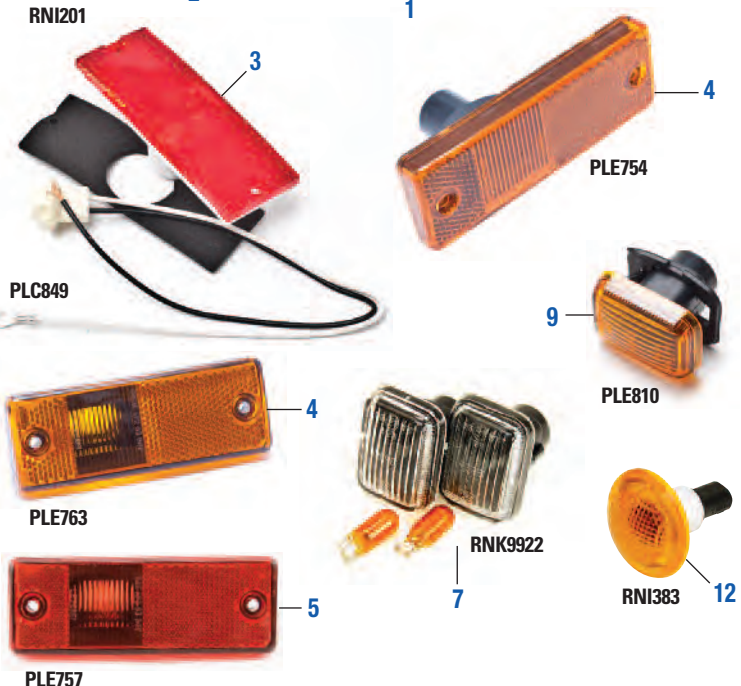



Ideas today for the cars of tomorrow



Hella 60/55w HB2 (9003) bulb included!



Hella Vision Plus Conversion Headlamp

High performance European headlamp technology - street legal D.O.T. version.

This is the most powerful, legally-approved headlamp on the market. These headlamps provide a precise, focused beam pattern that turns night into day! Single headlamp, includes 60 watt high beam / 55 watt low beam replaceable HB2 (9003) bulb and dust cover. Fits Series, II, IIA, III, Defender 90, 110, 130, and Range Rover Classic. Sold individually.....RNC673 \$ 46.99



PLI239

Replacement Headlight Bucket with adjuster kit

Fits Series II-III. WIPAC \$ 22.00
Fits Defender, Range Rover Classic. PLI239 \$ 23.50

WIPAC



Defender NAS Lamp Assemblies

Brighten up your Defender with our Wipac Lamp assemblies. Includes mounting screws and bulb holder. Bulb not included. When upgrading a '94 NAS 90 or '93 NAS 110 you need to purchase PLK289CK.

1. Stop/Tail Lamp, Red, ProLine (each).....PLC867 \$ 15.80
 2. Directional Lamp, Amber, ProLine (each).....PLC868 \$ 15.80
 3. Reverse Lamp, Clear, ProLine (each).....PLC869 \$ 15.80
 4. Plinth mounting base for lamps, ProLine (each).....PLC861 \$ 6.99
 5. Rear NAS Lamp kit Includes 5 plinths, 1 reverse, 2 directional, 2 stop/tail lampsPLK861 \$ 99.95
- Adaptor Kit for Series II-III, Allows NAS Lamp Kit PLK861 to plug directly into Series harnessPLK861AK \$ 98.00
- Connector Kit for LED Lamp Kit.....PLK289CK \$ 49.95



Normal Style Lamp Assemblies

Applicable to all models from Series I up to 1999 Defender. Automotive plastic construction for corrosion resistant operation with removable lens. Equipped with 36-inch long wire harness with bullet end connectors. 2.75 inch diameter. Bulb not included.

1. Stop / Tail Lamp, Red, Genuine (each).....RNF199 \$ 29.95
Stop / Tail Lamp, Red, ProLine (each).....PLF199 \$ 15.95
2. Directional or Park Lamp, Amber, Genuine (each).....RNF188 \$ 44.95
Directional or Park Lamp, Amber, ProLine (each).....PLF188 \$ 6.98
3. Park or Reverse Lamp, Clear, Genuine (each).....RNF187 \$ 20.95
Park or reverse Lamp, Clear, ProLine (each).....PLF187 \$ 7.98
4. Vehicle Kit, 2 park, 4 directional, 2 stop/tail lamps, GenuineRNK188 \$ 279.95
Vehicle Kit, 2 park, 4 directional, 2 stop/tail lamps, ProLinePLK188 \$ 69.95
5. Bulb, Directional, 12 Volt, Genuine (each).....RNE627 \$ 2.95
Bulb, Stop/Tail, 12 Volt, Genuine (each).....RNE626 \$ 2.59

Defender Normal Style Lamp Assemblies 1999 on

With fixed lenses. Bulbs included as indicated.

- Front Indicator Clear with Amber Bulb, GenuineRNL413 \$ 75.60
- Front Indicator Amber with Clear Bulb, GenuineRNL106 \$ 25.95
- Front Side/Parking Lamp Clear with Clear Bulb, Genuine.....RNL104 \$ 39.95
- Rear Stop/Tail Lamp Red with Clear Bulb, GenuineRNL155 \$ 22.26
- Rear Indicator Amber with Clear Bulb, Genuine.....RNH970 \$ 24.95

Defender Rear Light Waterproof Boot Kit

Kit includes new bulb sockets, rubber boots, clamps, connector repair kit and sealing compound. Does all five rear lamp assemblies. All components are available individually, see parts at left (does not include bulb).

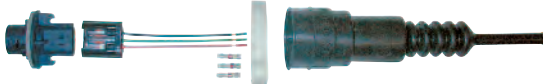

For Round NAS Defender Tail Lamps 1995 on, ProLineRNC9095 \$ 189.50

Rear Plate Lamp Assembly

All Defender & Series models. Includes bulbs, Genuine RNF439 \$ 23.50
ProLine PLF439 \$ 9.95



Interior Dome Lens & Lamp Assemblies

- Dome Lens, Range Rover Classic, ProLinePLE923 \$ 16.79
- Dome Lamp Assembly, Series & Defender, ProLine ..PLF319 \$ 23.50
- Switched Dome, Defender 1994 on, GenuineRNL159 \$ 39.45
- Bracket for Switched Dome lightRNN288 \$ 18.20
- Interior Lamp Assm, Def NAS 90 Soft Top '94-'97, Genuine.....RNS936 \$ 44.95





NEW LED Lamps for Series and Defender

Standard 2.75" inch lights as fitted to Series and Defender.

- 100% Waterproof
- Low Energy Consumption
- Long 100,000+ Hour Life
- Super Bright for Increased Visibility
- Easy to Install

Clear Parking Lamp	LED6085	\$ 29.95
Clear / Amber Directional Front	LED6489	\$ 29.95
Clear / Amber Directional Rear	LED6186	\$ 29.99
Amber Directional	LED6287	\$ 29.95
Red Stop / Tail	LED6388	\$ 29.95
Clear / Red Stop / Tail	LED6590	\$ 29.95
Adj. 12V Flasher Unit, Def. LED	LED6000	\$ 25.95
License Plate	LED6591	\$ 29.95



NAS Style LED Waterproof Lamps for Defender & Series



LED lamps are brighter and offer a stylish alternative to traditional halogen lighting.

- Longer life (typical LED life 100,000 hours)
- Low energy consumption • Waterproof

Stop/Tail Lamp, Rear	PLN289	\$ 49.95
Amber Directional Lamp, Front or Rear	PLN292	\$ 48.95
Clear Parking Lamp	LED6084	\$ 48.95
Rear Fog Guard Lamp	PLN290	\$ 49.95
Reverse Lamp, Rear	PLN291	\$ 49.95
Plinth, fits all	PLC861	\$ 6.99
Complete LED Lamp Kit includes 5 plinths, 1 reverse LED, 2 directional LED, 2 stop/tail LED lamps	PLK289	\$ 249.00
Connector Kit for LED Lamp Kit PLK289	PLK289CK	\$ 49.95
WIPAC Smart Load Device for NAS LED 12V	SLD12V	\$ 23.99
Adaptor Kit for Series II-III , Allows NAS Lamps to plug directly into Series harness	PLK861AK	\$ 98.00
NEW - LED CLEAR LAMP KIT DEFENDER		
Without Rear Fog Guard	PLK290	\$ 469.00
With Rear Fog Guard	PLK291	\$ 489.00





Headlamps

1994-'99, RH, Genuine.....	RNE817	\$ 239.95
1994-'99, LH, Genuine	RNE816	\$ 239.95
1994-'99, Headlamp Upgrade Kit...	RNK9923	\$ 299.00

Front Corner Lamp

1994-'99, RH, Genuine, Amber.....	RNE818	\$ 105.95
1994-'99, RH, ProLine, Clear	PLE818C	\$ 39.90
1994-'99, LH, Genuine, Amber.....	RNE789	\$ 105.95
1994-'99, RH, ProLine, Clear	PLE789C	\$ 39.90
1994-'99, Clear Corner Lamp Kit.....	RNK9921	\$ 69.29
1994-'99, Clear Side Marker Kit.....	RNK9922	\$ 69.88

Tailights

1994-'95, RH, up to VIN SA162389/ SA501704 (up to late < 1995)	RNE782	\$ 89.95
1994-'95, LH, up to VIN SA162389/ SA501704 (up to late < 1995)	RNE756	\$ 89.95
1995-'99, RH, from VIN SA162390/ SA501705 (late 1995 > on).....	RNE779	\$ 149.95
1995-'99, LH, from VIN SA162390/ SA501705 (late 1995 > on).....	RNE785	\$ 149.95

Rear Bumper

1994-'99, RH, Genuine.....	RNE758	\$ 69.95
1994-'99, LH, Genuine	RNE784	\$ 69.95
1994-'99, LH, ProLine.....	PLE784	\$ 29.95



Discovery I Lights, Lamps

Headlamp, Corner Lamp and Side Marker Lamp Upgrade Kits

Get the look, style and improved visibility for less money than replacing your original Discovery I lighting. Headlamp kit includes: 2 Genuine Land Rover headlamp assemblies with H4 halogen bulbs. Fits all Discovery I, 1994-'99, Genuine. Shown with optional clear front corner side lens kit.

Headlamp Upgrade Kit.....	RNK9923	\$ 299.00
Clear Corner Lamp Kit.....	RNK9921	\$ 69.29
Clear Side Marker Kit.....	RNK9922	\$ 69.88



Discovery II Lights, Lamps

Headlights

1999-'02.....RH, Genuine.....	RNE992	\$ 198.95
1999-'02.....LH, Genuine	RNE993	\$ 198.95
2003-'04.....RH, Genuine.....	RNI220	\$ 429.95
2003-'04.....LH, Genuine	RNI221	\$ 429.95

Fog Lamps

1999-'02.....RH, Genuine.....	RNE997	\$ 179.95
1999-'02.....LH, Genuine	RNE998	\$ 179.95
2003-'04.....RH, Genuine.....	RNH785	\$ 139.95
2003-'04.....LH, Genuine	RNI201	\$ 139.95

Tailights

1999-'02.....RH, Genuine.....	RNH094	\$ 194.95
1999-'02.....LH, Genuine.....	RNF597	\$ 194.95
2003-'04.....RH, Genuine.....	RNN858	\$ 138.03
2003-'04.....LH, Genuine	RNN857	\$ 131.28

Rear Bumper

1999-'02.....RH, Genuine.....	RNF600	\$ 109.95
1999-'02.....LH, Genuine.....	RNF601	\$ 109.95
2003-'04.....RH, Genuine.....	RNH683	\$ 139.95
2003-'04.....RH, ProLine.....	PLH683	\$ 45.00
2003-'04.....LH, Genuine	RNH684	\$ 139.95
2003-'04.....LH, ProLine	PLH684	\$ 45.00



Rear Plate Lamp Assembly
Discovery II RNF604 \$ 22.95

Front Corner Side Lamps

Fits Discovery II 1999-'02. Front indicator lamp. Lens comes with amber bulb.

Front Indicator Lamp, Amber, RH, ProLine	PLF593	\$ 34.29
Front Indicator Lamp, Clear, RH, ProLine	PLF593C	\$ 33.50
Front Indicator Lamp, Amber, LH, ProLine	PLF594	\$ 34.29
Front Indicator Lamp, Clear, LH, ProLine	PLF594C	\$ 33.50



Mirrors, Cigar Lighters, Speedometer Cables, Aerials

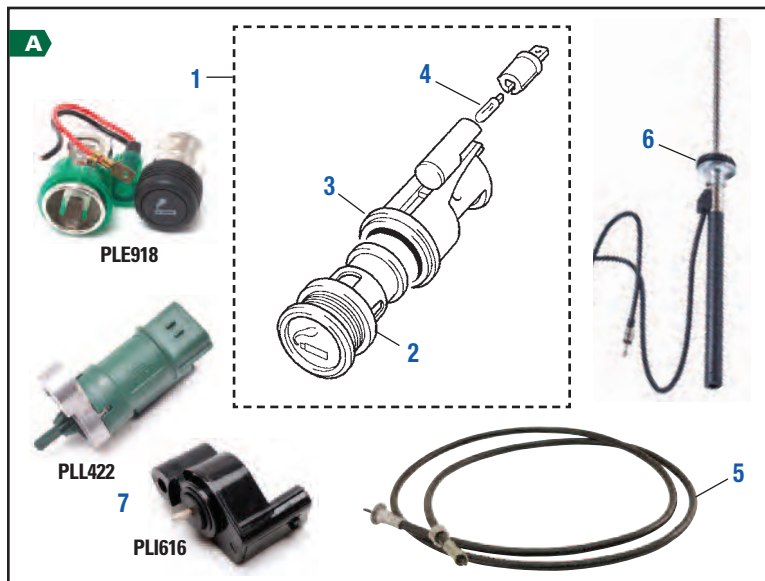

A Cigar Lighters, Speedo Cables, Aerials

1. Cigar Lighter Assembly, Defender, RRC, Discovery I, II, Genuine RNF450	\$ 44.95
Cigar Lighter Assembly, Defender, RRC, Discovery I, ProLine.....PLE918	\$ 12.95
Cigar Lighter Assembly, Range Rover P38A 4.0/4.6.....RNF641	\$ 35.95
Cigar Lighter Assembly, Discovery II, Freelander.....RNS879	\$ 29.70
Cigar Lighter Assembly, Defender 2007 on.....RNS881	\$ 29.95
Cigar Lighter, LR2, LR3.....RNS882	\$ 34.28

2. Cigar Lighter Pop Out Unit, Defender.....RNS880	\$ 39.17
3. Cigar Lighter Light Ring, LR2, LR3, L320.....RNS883	\$ 12.87
4. Bulb, 1.2 Watt.....RNE673	\$ 3.26
5. Speedometer Cable, Series II, IIA, Genuine.....RNE614	\$ 119.95
Series II, IIA, ProLine.....PLE614	\$ 17.95
Series III, Genuine.....RNT008	\$ 119.95
Series III, ProLine.....PLT008	\$ 19.95
Series III, RHD, Genuine.....RNS870	\$ 133.23
Defender, Upper 2-piece Style, for RHD or LHD, up to #AA266613, Genuine.....RNS871	\$ 94.95
Defender, Lower LHD up to #267696.....RNS873	\$ 55.63
Defender, Lower RHD up to #AA266613.....RNS872	\$ 94.95
Defender V8, RHD, non-NAS, Genuine.....PLS874	\$ 39.95
Defender 4cyl, RHD, ProLine.....PLL572	\$ 21.95
Defender, 1-Peice, LHD, Non-NAS up to 1977, Genuine.....RNL570	\$ 149.95
Defender, 1-Peice, LHD, Non-NAS up to 1977, ProLine.....PLL570	\$ 22.95
Cable Speedo-Transducer, Defender NAS 90 '94-95, NAS 110..PLE521	\$ 159.00
Speedometer Cable, RRC, Upper EFI.....RNE914	\$ 119.95
Speedometer Cable, RRC, Lower non-EFI.....RNS875	\$ 79.96
Trip Reset Cable, Series III, Genuine.....RNT018	\$ 22.19
6. Aerial Wing Mount Metal Type, Defender, Genuine.....RNS876	\$ 69.95
Aerial Assembly, Metal Type, Defender, Genuine.....RNS877	\$ 59.95
Rod Antenna, Discovery I, Genuine.....RNS878	\$ 54.95
7. Transducer Vehicle Speed Sensor, 3.9 Litre.....RNC860	\$ 159.95
Speed Transducer Automatic Discovery II, P38A & L322.....RNI405	\$ 101.13
Speed Transducer Defender V8, 300 TDI & TD5, Genuine.....RNL422	\$ 89.95
Speed Transducer Defender V8, 300 TDI, ProLine.....PLL422	\$ 59.95
Speed Transducer Defender 4.0L V8 & 2.8L 6 CYL, Genuine.....RNI616	\$ 198.78
Speed Transducer Defender 4.0L V8 & 2.8L, ProLine.....PLI616	\$ 109.95

Mirrors

Series II, IIA, III
6" x 10" Mirror Head
RNF260 \$ 13.99

5" x 7" Mirror Head
RNF259 \$ 12.50

Round Mirror Head
PLC633 \$ 11.99 ea

8 1/2" Mirror Arm
Mounts to wing top & Series IIA hinges
with mirror mount. Fits RNF259 & RNF260.
ARM2 \$ 14.50

Interior Mirror
Series II, IIA, III, PLB905 \$ 12.99
Defender, RNI505 \$ 54.95

Discovery II Mirrors
Mirror Glass, LH Flat, Discovery II
RNS458 \$ 52.29
Mirror Glass, RH Convex, Discovery II
RNS459 \$ 69.95



Defender Mirrors

X Large
6" x 10" Head
with 6 1/2" arm
RNH716 \$ 42.50 ea

Standard
5" x 8" head
with 6 1/2" arm
RNE314 \$ 36.00 ea

Defender Convex Mirror Assembly

Standard size 5" x 8", head with 6 1/2" arm, shown above.....RNE314	\$ 36.00 ea
All of these can be mounted on Series with Defender door hinge kits.	
Mirror Arm, Defender.....RNE313	\$ 53.23
Replacement convex mirror head 5 x 8", Defender, Genuine.....RNE315	\$ 84.95 ea
Replacement convex mirror head 5 x 8", Defender, ProLine.....PLE315	\$ 22.95 ea
Replacement flat mirror head 5 x 8", Defender.....RNF400	\$ 39.95 ea
Mirror Head Assy Flat Glass, Defender.....RNC825	\$ 59.95

Mirror Kits

Includes standard 5"x8" mirror and arm, top door hinge, sealing washer, and all hinge bolts.

5" x 8" Mirror Kit, LH.....RNK841L	\$ 99.85
5" x 8" Mirror Kit, RH.....RNK841R	\$ 99.85
10" x 6" Mirror Kit, LH.....RNK851L	\$ 99.85
10" x 6" Mirror Kit, RH.....RNK851R	\$ 99.85



Genuine Door Hinge Kits
D90, Series II-III 88".....RNK8060 \$ 289.00
D110, Series II-III 109".....RNK8061 \$ 549.00 ea

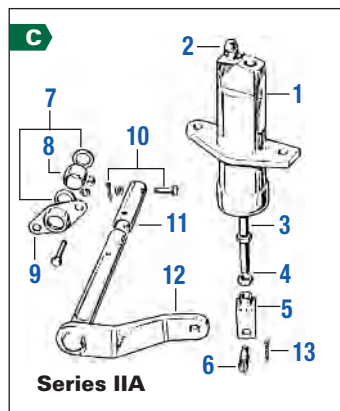
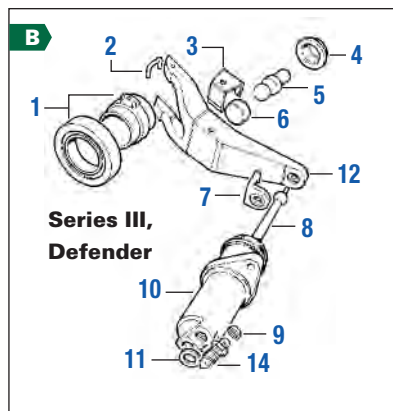
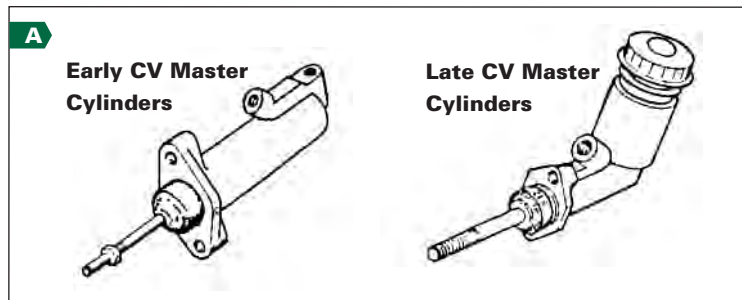

2. Bleed Screw, Genuine.....	RNC380	\$ 3.95
Bleed Screw, ProLine.....	PLC380	\$ 1.56
3. Push Rod, Genuine.....	RNC293	\$ 29.95
4. Lock Nut, Genuine.....	RNS034	\$ 1.99
5. Clevis for Push Rod, Genuine.....	RNB638	\$ 4.60
6. Threaded Clevis Pin, Genuine.....	RNA932	\$ 29.95
7. Felt Ring for Spherical Bushing, Genuine.....	RNA946	\$ POA
8. Spherical Bush, Genuine.....	RNC733	\$ 39.95
9. Housing for Spherical Bush, Genuine.....	RNB380	\$ 9.95
10. Pin for Cross Shaft (two required), Genuine.....	RNC290	\$ 3.96
11. Connecting Tube, Genuine.....	RNC403	\$ 101.87
12. Operating Lever, 2.25 Litre, Genuine.....	RNC294	\$ 38.75
13. Split pin for clevis, Genuine.....	RNB315	\$ POA

Rubber Boot for Cross Shaft

Seals, Cross Shaft to Bell Housing, Genuine (not shown).....	RNC371	\$ 18.95
--	--------	----------

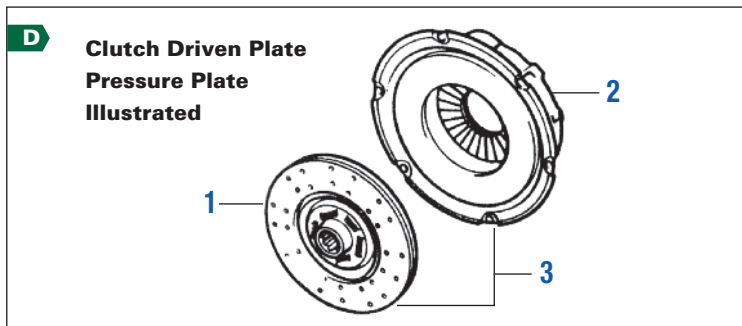

A Clutch Master Cylinders

Series II, IIA 1959 - 1968 early CV type, ProLine.....	PLC752	\$ 66.95
Series IIA, III, Defender all models, 1969 - 2007 late CV type with fluid reservoir, Genuine.....	RNF289	\$ 139.95
ProLine.....	PLF289	\$ 69.50
Rebuild kit for all CV Master Cylinders 1959 - 2007, Genuine.....	RNC720	\$ 24.95
Cap with seal for Late CV Master Cylinder, Genuine.....	RNF290	\$ 29.95
Cap with seal for Late CV Master Cylinder, ProLine.....	PLF290	\$ 4.98

B Clutch Withdrawal Mechanism

Series III, Defender		
1. Throw-Out Bearing, Genuine.....	RNE223	\$ 68.29
Throw-Out Bearing, ProLine.....	PLE223	\$ 29.95
2. Plastic Staple, Genuine.....	RNC483	\$ 1.39
3. Retainer for Operating Arm, Genuine.....	RNC465	\$ 2.95
4. Retainer Collar, Genuine.....	RNC466	\$ 3.95
5. Fulcrum, 3.9 Litre, Genuine.....	RNE172	\$ 14.95
6. Bush for operating arm, Genuine.....	RNC464	\$ 4.50
7. Retainer for Push Rod, Genuine.....	RNC493	\$ 4.95
8. Push Rod for Slave Cylinder, 2.25 Litre, Genuine.....	RNC463	\$ 47.69
Push Rod for Slave Cylinder, Defender w/LT77, All 4 cyl, Genuine...RNI700	\$ 10.99	
Push Rod for Slave Cylinder, Defender w/R380, All 4 cyl, Genuine...RNI701	\$ 79.95	
9. Dust Cap for Bleeder, Genuine.....	RNF316	\$ 3.95
10. Slave Cylinder, 2.25, 2.5 Litre & 200 TDI w/LT77 Gearbox, Genuine.RNC535	\$ 139.00	
Slave Cylinder, 2.25, 2.5 Litre & 200 TDI w/LT77 Gearbox, ProLine...PLC535	\$ 39.50	
Slave Cylinder, 3.9 Litre V8, w/LT77 & R380, Genuine.....RNE222	\$ 89.45	
Slave Cylinder, 3.9 Litre V8, w/LT77 & R380, ProLine.....PLE222	\$ 36.80	
Slave Cylinder, 300 Tdi, up to #56A0669086K, Genuine.....RND627	\$ 139.95	
Slave Cylinder, 300 Tdi, up to #56A0669086K, ProLine.....PLD627	\$ 38.29	
Slave Cylinder, 300 Tdi from #56A0669087K & Td5, Genuine.....RND493	\$ 119.95	
Slave Cylinder, 300 Tdi from #56A0669087K & Td5, ProLine.....PLD493	\$ 64.50	
11. Compression Washer, Genuine.....RNA986	\$ 0.89	
12. Release Lever, Series III, Defender V8 & Td5, Genuine.....RNC481	\$ 119.95	
Release Lever, Defender 2.5, 200 & 300 Tdi, Genuine.....RNH396	\$ 46.99	

C Clutch Slave Cylinder & Linkage

Series II & IIA (Located at Bell Housing area)		
1. Slave Cylinder, ProLine.....	PLB599	\$ 48.50

D Clutch Driven Plate - NEW

1. Series II, IIA thru 1966, 9", ProLine.....	PLC546	\$ 89.94
Series IIA, III 9.5", Genuine.....	RNE170	\$ 129.95
Series IIA, III 9.5", ProLine.....	PLE170	\$ 79.88
Defender V8, 10", Genuine.....	RNE220	\$ 289.95
Defender V8, 10", ProLine.....	PLE220	\$ 84.20
Defender 2.5, 200 & 300 Tdi, 10", Genuine.....	RNI702	\$ 229.95
Defender TD5, 10", Genuine.....	RNI703	\$ 219.95

Clutch Pressure Plate - NEW

2. Series II, IIA thru 1966, 9", ProLine.....	PLC547	\$ 139.00
Series II, IIA, 9.5", ProLine.....	PLC467	\$ 139.80
Series III, 2.25, 2.6 Litre, 9.5", Genuine.....	RNC486	\$ 139.00
Series III, 2.25, 2.6 Litre, 9.5", ProLine.....	PLC486	\$ 82.95
Series III, Defender V8, 10", Genuine.....	RNC485	\$ 389.95
Defender 2.5, 200 & 300 Tdi, 10", Genuine.....	RNH534	\$ 169.95
Defender TD5, 10", Genuine.....	RNI704	\$ 275.01

Complete Clutch Kit

Includes driven plate, pressure plate and throwout bearing.

3. Series III, ProLine.....	PLB372	\$ 189.95
Defender V8, Genuine.....	RNI705	\$ 319.95
Defender V8, ProLine.....	PLH608	\$ 259.00
Defender 2.5 NA, 200 & 300 Tdi, Genuine.....	RNI705	\$ 319.95

Throw-Out Bearing Assembly

Series III & Defender all models, Genuine.....	RNE223	\$ 68.29
Series III & Defender all models, ProLine.....	PLE223	\$ 29.95



Stainless Steel Clutch Lines

Series II-IIA.....	RNA606	\$ 27.50
Series III.....	RNA211	\$ 39.50
4cyl Defender.....	RNA1690	\$ 44.50



Which Defender gearbox do I have?

LT77, LT77S - Reverse is forward to the left.
R380 - Reverse is rearward to the right.



LT77 / LT77S



R380

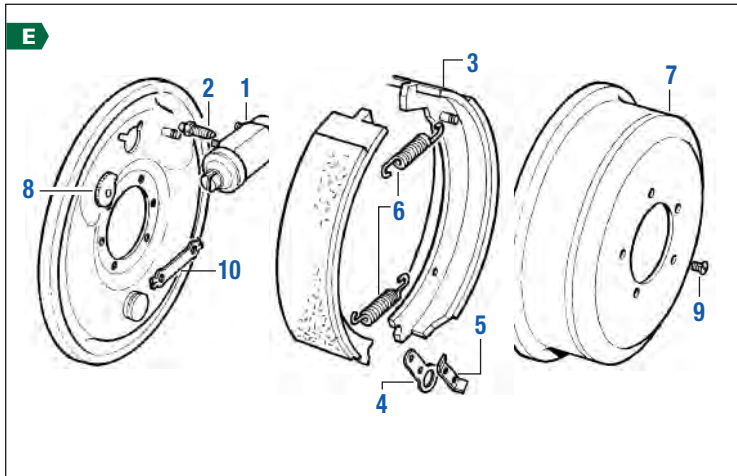

E Wheel Cylinders, Shoes, Drums

	Genuine	ProLine
1. 88", Series II, IIA, III Front Right	RNB535 \$ 93.50	PLB535 \$ 36.85
88", Series II, IIA, III Front Left	RNB536 \$ 119.95	PLB536 \$ 36.85
88", Series II, IIA, III Rear Right	RNB537 \$ 129.95	PLB537 \$ 39.50
88", Series II, IIA, III Rear Left	RNB538 \$ 129.95	PLB538 \$ 39.50
109", 2.25 Litre Front Right	RNB542 \$ POA	PLB542 \$ 36.90
109", 2.25 Litre Front Left	RNB541 \$ POA	PLB541 \$ 36.90
109", 2.25 Litre Rear Right	RNB535 \$ 93.50	PLB535 \$ 36.85
109", 2.25 Litre Rear Left	RNB536 \$ 119.95	PLB536 \$ 36.85
109", 2.6, 3.5 Litre Front Right	RNC600 \$ POA	PLC600 \$ 38.90
109", 2.6, 3.5 Litre Front Left	RNC599 \$ 257.75	PLC599 \$ 38.90
109", 2.6, 3.5 Litre Rear Right	RNB535 \$ 93.50	PLB535 \$ 36.85
109", 2.6, 3.5 Litre Rear Left	RNB536 \$ 119.95	PLB536 \$ 36.85
Defender 90 thru Oct '93 Rear Right	RNF349 \$ 249.95	PLF349 \$ 82.43
Defender 90 thru Oct '93 Rear Left	RNF348 \$ 249.95	PLF348 \$ 82.43
Defender 110 thru Oct '93 Rear Right	RNE635 \$ 118.90	PLE635 \$ 29.95
Defender 110 thru Oct '93 Rear Left	RNE636 \$ 118.90	PLE636 \$ 29.95

2. Bleed Screws for Wheel Cylinders, Genuine	RNC380	\$ 3.95
Bleed Screws for Wheel Cylinders, ProLine	PLC380	\$ 1.56
Dust Cap for bleed screws, Genuine	RNF316	\$ 3.95

Bonded Brake Shoes sold in axle sets

Enough for 2 wheels

3. 88", 90" bonded shoe axle set, front or rear, Mintex	PLF320M	\$ 49.95
109" 2.25 Litre bonded shoe axle set, front only, Mintex	PLF343M	\$ 59.20
2.6, 3.5 Litre bonded shoe axle set, front only, ProLine	PLF344	\$ 69.25
109", 110" bonded shoe axle set, rear only, all models, Mintex	PLF321M	\$ 58.90
Series IIA, III 2.5 Litre brake shoes for handbrake, ProLine	PLF342	\$ 19.95
4. 88", 90" retainer for brake shoes, Genuine	RND064	\$ 17.95
5. 88", 90" locker for retainer, Genuine	RND065	\$ 2.95

Shoe Return Springs

6. 88" front & rear, all models thru June '80, Top, Genuine	RNC165	\$ 5.20
Top, ProLine	PLC165	\$ 1.55
Bottom, Genuine	RNA952	\$ 5.95
109", 110" all models with drum brakes, Front, Genuine	RNA993	\$ 7.20
Rear top, Genuine	RNC345	\$ 29.95
Rear top, ProLine	PLC345	\$ 3.95
Rear bottom, Genuine	RNC273	\$ 8.95
90" all models with rear drum brakes, Top, Genuine	RNC165	\$ 5.20
Top, ProLine	PLC165	\$ 1.55
Bottom, Genuine	RNA952	\$ 5.95

Brake Drums

7. 88" Series II, IIA, 10", ProLine	PLC545	\$ 42.50
88" Series III, 90" rear, 10", ProLine	PLC534	\$ 39.50
109" Series IIA, III 2.25 Litre 1971 on, 110" rear, ProLine	PLC504	\$ 45.99
8. Adjuster Kit does 4 adjusters (109" requires 2 kits), ProLine	PLE588	\$ 29.99
9. Drum Screw Fits all Series, ProLine	PLA915	\$ 0.50

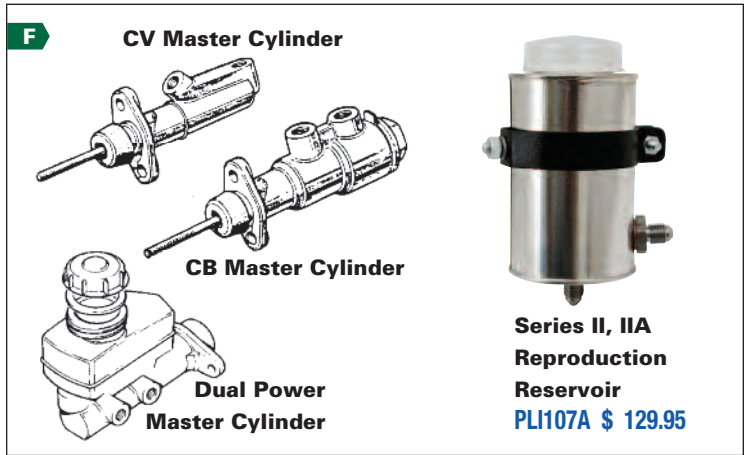

F Brake Master Cylinders

Series II, IIA 88" CB, 1959 - 1967, ProLine	PLC228	\$ 64.50
Series IIA 88" CV, 1967 - 1968, ProLine	PLC752	\$ 66.95
Series II, IIA 109", 1959 - 1967, CB, ProLine	PLC429	\$ 69.48
Series IIA 109", 1968 - 1969, CV, ProLine	PLC753	\$ 105.00
Series Single System Power, except V8	PLH407	\$ 69.95
Series IIA, III 88" Dual Power, Genuine	RNC454	\$ 666.99
Series IIA, III 88" Dual Power, ProLine	PLC454	\$ 138.00
Series IIA, III, 109" Dual Power, Genuine	RNC762	\$ 780.62
Series IIA, III, 109" Dual Power, ProLine	PLC762	\$ 129.00
Series II, IIA Reservoir, Reproduction	PLI107A	\$ 129.95
CB Master Cylinder Rebuild Kit, Series 88	PLF292	\$ 8.95
CB Master Cylinder Rebuild Kit, Series 109	PLC625	\$ 9.95
CV Master Cylinder Rebuild Kit, Series 109	RNC769	\$ 37.50

G Brake Master Cylinder Servo Assembly

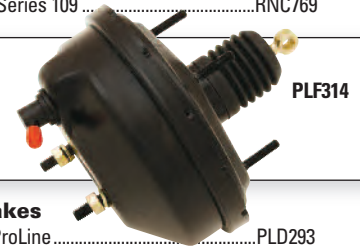

G Servo Assembly for Brakes

1. Defender all Models up to 1991, ProLine	PLD293	\$ 199.00
Defender all Models w/out ABS 1991 on, ProLine	PLH911	\$ 139.00
Defender all Models with ABS 1999 on, Genuine	RNI170	\$ 459.95
Series IIA-III, 2.25 Petrol, Genuine	RNF314	\$ 549.95
Series IIA-III, 2.25 Petrol, ProLine	PLF314	\$ 158.20
2. Series IIA-III, Vacuum Hose, Genuine	RNI718	\$ 8.95



H Brake Master Cylinders

Defender 110 1983 - 1986, Genuine	RNI706	\$ 269.95
Defender 110 1983 - 1986, ProLine	PLI706	\$ 69.95
Defender 90 1994 - 1997, Genuine	RNF285	\$ 329.00
Defender 90 1994 - 1997, ProLine	PLF285	\$ 179.00
Discovery I 1995 - 1999 with ABS, ProLine	PLB200	\$ 269.00
Discovery II 1999 - 2004 with ABS, ProLine	PLD999	\$ 339.00
Range Rover Classic 1988-1989, Non-ABS, ProLine	PLB180	\$ 259.95
Range Rover P38A, Genuine	RNH682	\$ POA
Repair Kit - Brake Master Cylinder, Discovery II, Genuine	RNH114	\$ 89.95
Reservoir Kit Brake Master Cylinder, Defender, Genuine	RNI169	\$ 89.95
Cap Brake Reservoir w/Fluid Level, Defender, Genuine	RNI168	\$ 29.95

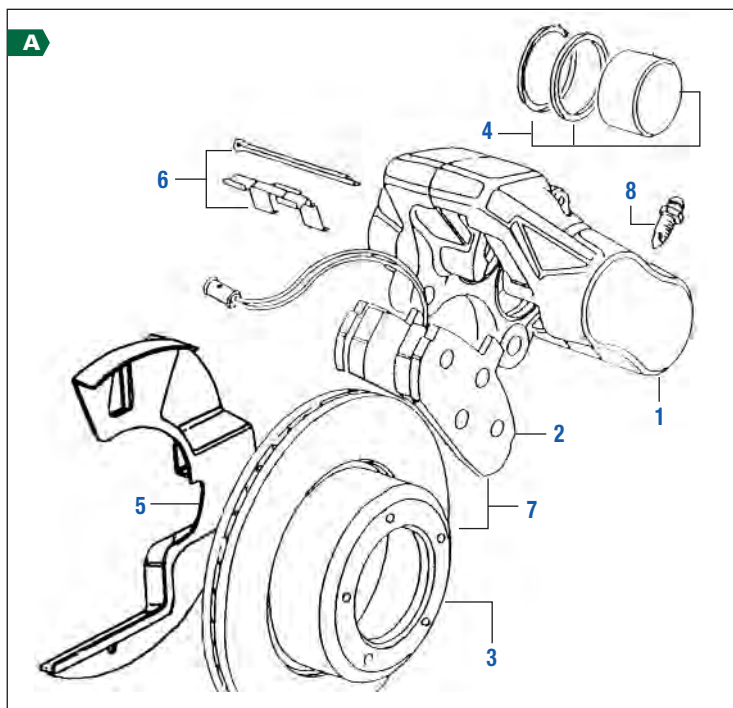

A NEW ProLine Brake Calipers (no Core Charge)

1. Defender 90/110 1993-1997

Defender 90, Front Caliper, RH, ProLine	PLF300A	\$ 139.00
Defender 90, Front Caliper, LH, ProLine	PLF301A	\$ 139.00
Defender 90, Rear Caliper, RH, ProLine	PLB198A	\$ 99.80
Defender 90, Rear Caliper, LH, ProLine	PLB197A	\$ 99.80
Defender 110, Front Caliper, RH, Solid Retainer Pin, ProLine	PLF200	\$ 127.60
Defender 110, Front Caliper, LH, Solid Retainer Pin, ProLine	PLF201	\$ 127.60
Defender 110, Front Caliper, RH, Split Retainer Pin, ProLine	PLL942	\$ 129.00
Defender 110, Front Caliper, LH, Split Retainer Pin, ProLine	PLL943	\$ 129.00
Defender 110, Rear Caliper, RH up to 1A6144, Genuine	RNH346	\$ 249.95
Defender 110, Rear Caliper, RH, ProLine	PLH346A	\$ 88.49
Defender 110, Rear Caliper, LH, Genuine	RNH347	\$ 262.40
Defender 110, Rear Caliper, LH, ProLine	PLH347A	\$ 88.49

Discovery I 1995-1999

Front Caliper, RH, ProLine	PLB192A	\$ 129.50
Front Caliper, LH, ProLine	PLB191A	\$ 149.00
Rear Caliper, NEW, RH, ProLine	PLB198A	\$ 99.80
Rear Caliper, NEW, LH, ProLine	PLB197A	\$ 99.80

Discovery II 1999-2004 & Range Rover P38A 1995-2002

Front Caliper, NEW, RH, ProLine	PLD016A	\$ 79.99
Front Caliper, NEW, LH, ProLine	PLD017A	\$ 79.99
Rear Caliper, NEW, RH, ProLine	PLD004	\$ 89.95
Rear Caliper, NEW, LH, ProLine	PLD005	\$ 89.95

Range Rover Classic 1987-1995

Front Caliper, NEW, 1987-1989 RH, ProLine	PLB014A	\$ 129.00
Front Caliper, NEW, 1987-1989 LH, ProLine	PLB015A	\$ 129.00
Front Caliper, NEW, 1993-1995 RH, From Vin #PA637568	PLD259	\$ 299.95
Front Caliper, NEW, 1993-1995 LH, From Vin #PA637568	PLD258	\$ 299.95
Front Caliper, NEW, ABS & Hunter, '90-1993, RH, ProLine	PLB011A	\$ 149.00
Front Caliper, NEW, ABS & Hunter, '90-1993, LH, ProLine	PLB017A	\$ 149.00
Rear Caliper, NEW, 1987-1992 RH 10mm, ProLine	PLB018A	\$ 109.50
Rear Caliper, NEW, 1987-1992 LH 10mm, ProLine	PLB010A	\$ 109.50
Rear Caliper, NEW, 1993-1995 RH 12mm, ProLine	PLB198A	\$ 99.80
Rear Caliper, NEW, 1993-1995 LH 12mm, ProLine	PLB197A	\$ 99.80

Genuine & ProLine Brake Pads

2. Defender 90 1994-2010

Front, Brake Pad set, Genuine	RNF302	\$ 134.95
Front, Brake Pad set, ProLine	PLF323	\$ 36.50
Rear, Brake Pad set, Genuine	RNF303	\$ 96.85
Rear, Brake Pad set, ProLine	PLB195	\$ 24.95

Defender 110

Front, Brake Pad set, 1983-1993, Genuine	RNF323	\$ 98.44
Front, Brake Pad set, 1983-1993, ProLine	PLF323	\$ 36.50
Front, Brake Pad set, Pre '86, Split Pin Type, ProLine	PLI512	\$ 34.95
Front, Brake Pad set, 1994-on, Genuine	RNF302	\$ 134.95
Rear, Brake Pad set, 1994-2001, Genuine	RNH601	\$ 94.50
Rear, Brake Pad set, 1994-2001, ProLine	PLH601	\$ 39.95
Rear, Brake Pad set, 2002-on, Genuine	RNI162	\$ 89.60
Rear, Brake Pad set, 2007-2010, Defender 110, ProLine	PLI162	\$ 39.95

Discovery I 1994-1999

Front, Brake Pad set, Genuine (w/o sensor)	RNB208	\$ 97.95
Front, Brake Pad set, ProLine	PLB208	\$ 36.50
Rear, Brake Pad set, Genuine	RNF303	\$ 96.85
Rear, Brake Pad set, Genuine (w/o sensor)	RNB195	\$ 102.04
Rear, Brake Pad set, ProLine (w/o sensor)	PLB195	\$ 24.95

Discovery II 1999-2004

Front, Brake Pad set, Genuine	RND036	\$ 84.95
Front, Brake Pad set, ProLine	PLD036	\$ 42.95
Rear, Brake Pad set, Genuine	RND020	\$ 129.95
Rear, Brake Pad set, ProLine	PLD242	\$ 39.50

Range Rover Classic 1987-1995

Front, Brake Pad set, '87-1989, Genuine	RNB001	\$ 83.50
Front, Brake Pad set, '87-1989, non ABS, ProLine	PLB001	\$ 35.95
Front, Brake Pad set, '90-1995, Genuine	RNB002	\$ 62.50
Front, Brake Pad set, '90-1995, ProLine	PLB208	\$ 36.50
Rear, Brake Pad set, '87-1995, Genuine	RNB004	\$ 119.95
Rear, Brake Pad set, '87-1995, ProLine	PLB004	\$ 49.99

Range Rover P38A 1995-2002

Front, Brake Pad set, ProLine	PLD036	\$ 42.95
Rear, Brake Pad set, ProLine	PLD242	\$ 39.50

Range Rover L322, 2003 on

Front, Brake Pad set up to 4A159171, Genuine	RNL590	\$ 129.95
Front, Brake Pad set up to 4A15917, ProLine	PLH715	\$ 61.95
Front, Brake Pad set, 4.2 ltr Supercharged	RNI369	\$ 179.95
Front, Brake Pad set, L322 & RR Sport, ProLine	PLI369	\$ 69.95
Rear, Brake Pad set up to 6A000001, Genuine	RNH594	\$ 169.95
Rear, Brake Pad set 2006 on, Genuine	RNL571	\$ 119.95

LR3, 2004 on

Brake Pad set, front, Genuine	RNH721	\$ 99.51
Brake Pad set, front, ProLine	PLH721	\$ 69.95
Brake Pad set, rear, Genuine	RNH958	\$ 135.95
Brake Pad set, rear, ProLine	PLH958	\$ 54.50

Genuine & ProLine Brake Rotors

3. Defender 90, 110, 130

Front solid rotor, each, Genuine	RNB006	\$ 89.95
Front solid rotor, each, ProLine	PLB006A	\$ 39.50
Front vented rotor, each, Genuine	RNB022	\$ 99.50
Front vented rotor, each, ProLine	PLB022A	\$ 39.50
Rear rotor, each, 110, 130, 1994-1998, Genuine	RNN954	\$ 86.40
Rear rotor, each, 110, 130, 1998-2013, Genuine	RNI154	\$ 98.95
Rear rotor, each, 110, 130, 1998-2013, ProLine	PLI154	\$ 39.95
Rear rotor, each, 90 only 1994-2013, Genuine	RNI721	\$ 115.16
Rear rotor, each, 90 only 1994-2013, ProLine	PLB012A	\$ 39.00

Discovery I 1995-1999

Front, rotor, each, Genuine	RNB006	\$ 89.95
Front, rotor, each, ProLine	PLB006A	\$ 39.50
Rear, rotor, each, Genuine	RNI721	\$ 115.16
Rear, rotor, each, ProLine	PLB012A	\$ 39.00

Discovery II 1999-2004

Front, rotor, each, Genuine	RND013	\$ 99.50
Front, rotor, each, ProLine	PLD013A	\$ 45.00
Front, Disc Set Pair, Slotted & Drilled, ProLine	PLD013SD	\$ 139.00
Rear, rotor, each, Genuine	RND024	\$ 98.50
Rear, rotor, each, ProLine	PLD024A	\$ 39.95
Rear, Disc Set Pair, Slotted & Drilled, ProLine	PLD024SD	\$ 129.00

Range Rover Classic 1987-1995

Front rotor '87-1989, each, Genuine	RNB006	\$ 89.95
Front rotor '87-1989, each, ProLine	PLB006A	\$ 39.50

Front rotor '90-1995, each, Genuine.....	RNB022	\$ 99.50
Front rotor '90-1995, each, ProLine.....	PLB022A	\$ 39.50
Rear rotor '87-1995, each, Genuine.....	RNI721	\$ 115.16
Rear rotor '87-1995, each, ProLine.....	PLB012A	\$ 39.00
3. Range Rover P38A 1995-2002		
Front rotor, each, Genuine.....	RND028	\$ 119.95
Front rotor, each, ProLine.....	PLD028A	\$ 44.50
Rear rotor, each, Genuine.....	RND024	\$ 98.50
Rear rotor, up to 6A000001, each, Genuine.....	PLD024A	\$ 39.95
Rear, Disc Set Pair, Slotted & Drilled, ProLine.....	PLD024SD	\$ 129.00
Range Rover L322 2003 on		
Front rotor, up to 3A130140, each, Genuine.....	RNH909	\$ 179.00
Front rotor, up to 3A130140, each, ProLine.....	PLH909	\$ 68.00
Front rotor, from 4A159171 up to 6A228066, each, Genuine.....	RNH954	\$ 124.80
Rear rotor, up to 6A000001, each, Genuine.....	RNH955	\$ 139.95
Rear rotor, up to 6A000001, each, ProLine.....	PLH955	\$ 58.00
LR3 V8 only, 2004 on		
Front rotor, each, Genuine.....	RNH956	\$ 99.50
Front rotor, each, ProLine.....	PLH956	\$ 59.95
Rear rotor, each, Genuine.....	RNI350	\$ 97.50
Rear rotor, each, ProLine.....	PLI350	\$ 48.50
LR3 V6		
Front rotor, each, Genuine.....	RNL493	\$ 112.20
Rear rotor, each, Genuine.....	RNL515	\$ 115.38

Caliper Rebuild Kits Includes pistons and seals for one caliper.

4. Defender 90 front caliper kit per side, ProLine.....	PLF304	\$ 29.80
Defender 90 Rear caliper kit per side, Genuine.....	RNB246	\$ 96.65
Defender 90 rear caliper kit per side, ProLine.....	PLB246	\$ 29.95

Discovery I 1994-1999

Front caliper kit per side, ProLine.....	PLB176	\$ 36.50
Rear caliper kit per side, ProLine.....	PLB246	\$ 29.95

5. Mud Shield

Defender 90 front RH, Genuine.....	RNB178	\$ 29.50
Defender 90 front LH, Genuine.....	RNB177	\$ 29.50
Defender 90 rear RH, Genuine.....	RNB206	\$ 48.50
Defender 90 rear LH, Genuine.....	RNB205	\$ 48.50
Defender 110 front RH, Genuine.....	RNE195	\$ 119.00
Defender 110 front LH, Genuine.....	RNE196	\$ 119.00
Defender 110 rear RH, Genuine.....	RNB206	\$ 48.50
Defender 110 rear LH, Genuine.....	RNB205	\$ 48.50

Discovery I 1994-1999, Range Rover Classic 1987-1995

Discovery I Front RH, Genuine.....	RNB178	\$ 29.50
Discovery I Front LH, Genuine.....	RNB177	\$ 29.50
Discovery I Rear RH, Genuine.....	RNI183	\$ 172.90
Discovery I Rear LH, Genuine.....	RNI182	\$ 172.90

Discovery II 1999-2004, Range Rover P38A 1996-2002

Discovery II Front RH, Genuine.....	RND964	\$ 47.95
Discovery II Front LH, Genuine.....	RND965	\$ 47.95
Discovery II Rear RH & LH, Genuine.....	RNE004	\$ 84.95

6. Fixing Kits for Brake Pads

Defender 110 NAS , Discovery I, front, solid disc, ProLine.....	PLB204	\$ 3.99
Range Rover Classic , Defender 90 NAS, front, vented, ProLine.....	PLD161	\$ 6.95
Range Rover Classic, front, non-vented, ProLine.....	PLH320	\$ 5.50
Range Rover Classic, Defender 90, Discovery I, rear, solid disc, ProLine.....	PLH321	\$ 4.50

7. Brake Kits Genuine & ProLine kits include 2 pads, 2 rotors & hardware.

Range Rover Classic 1987-1995

Front Brakes non ABS, Genuine.....	RNK6101	\$ 209.00
Front Brakes non ABS, ProLine.....	PLK6101	\$ 109.00
Rear Brakes non ABS LH Sensor, Genuine.....	RNK6102	\$ 299.50
Rear Brakes non ABS LH Sensor, ProLine.....	PLK6102	\$ 129.00
Rear Brakes non ABS RH Sensor, Genuine.....	RNK6103	\$ 299.50
Rear Brakes non ABS RH Sensor, ProLine.....	PLK6102	\$ 129.00
Front Brakes w/ABS, Genuine.....	RNK6104	\$ 239.00
Front Brakes w/ABS, ProLine.....	PLK6104	\$ 109.99
Rear Brakes w/ABS, Genuine.....	RNK6105	\$ 299.00
Rear Brakes w/ABS, ProLine.....	PLK6105	\$ 129.00

7. Range Rover P38A 1995-2002

Front Brakes, Genuine.....	RNK6112	\$ 389.00
----------------------------	---------	-----------

Front Brakes, ProLine.....	PLK6112	\$ 124.00
----------------------------	---------	-----------

7. Range Rover P38A 1995-2002 (con't)

Rear Brakes, Genuine.....	RNK6113	\$ 319.00
Rear Brakes, ProLine.....	PLK6113	\$ 99.50

Discovery I 1995-1999

Front Brakes, Genuine.....	RNK6106	\$ 249.99
Front Brakes, ProLine.....	PLK6106	\$ 110.00
Rear Brakes, Genuine.....	RNK6107	\$ 279.00
Rear Brakes, ProLine.....	PLK6107	\$ 94.50

Discovery II 1999-2004

Front Brakes, Genuine.....	RNK6114	\$ 299.50
Front Brakes, ProLine.....	PLK6114	\$ 129.90
Rear Brakes, Genuine.....	RNK6115	\$ 299.85
Rear Brakes, ProLine.....	PLK6115	\$ 99.99

Defender 90

Front Brakes, Genuine.....	RNK6110	\$ 299.00
Front Brakes, ProLine.....	PLK6110	\$ 112.99
Rear Brakes, Genuine.....	RNK6111	\$ 299.50
Rear Brakes, ProLine.....	PLK6111	\$ 98.50

Defender 110

Front Brakes, Genuine.....	RNK6108	\$ 249.00
Front Brakes, Genuine.....	PLK6108	\$ 109.99
Rear Brakes, Drums and Shoes, Defender 110 NAS, Genuine.....	RNK6109	\$ 628.19
Rear Brakes, Drums and Shoes, Defender 110 NAS, Proline.....	PLK6109	\$ 149.50

8. Bleed Screw

Defender, Range Rover Classic, Discovery I, Genuine.....	RNB023	\$ 6.95
Range Rover P38A, Discovery II, Genuine.....	RND966	\$ 5.59

Complete Series Vehicle Brake Pipe Kits

Includes all Genuine metal and rubber flex lines with sealing washers and nuts.

88" early Series IIA , single system kit.....	RNK680	\$ 169.90
109" single system kit	RNK681	\$ 184.50
88" Series IIA , dual power system kit.....	RNK682	\$ 209.66
88" Series III , dual power system kit.....	RNK683	\$ 229.95



B Stainless Steel Brake Line Kits - DOT approved

These extended flexible stainless steel brake line kits are designed for Land Rovers with lifted suspension. Replaces your rubber flex lines. Equipped with factory fittings. No adapters required. Directions included.

Extended Length + 2" inch

Defender	SBL2003E	\$ 89.50
Discovery I	SBL3004E	\$ 129.00
Discovery II	SBL6004E	\$ 119.00
Range Rover Classic 1986-1989	SBL5005E	\$ 165.00
Range Rover Classic 1990-1991.....	SBL5007E	\$ 179.99
Range Rover Classic 1992-1995.....	SBL5006E	\$ 219.00

Extended Length + 4" inch

Defender	SBL2004E	\$ 99.50
Discovery I	SBL3005E4	\$ 129.00
Discovery II	SBL6005E4	\$ 119.00
Range Rover Classic 1992-1995	SBL5006E4	\$ 199.99

Series II-III Standard Length

Series II, IIA, 88"	RNA1076	\$ 79.50
Series III, 88".....	RNA1032	\$ 79.50
Series II, IIA, 109".....	RNA1091	\$ 139.95
Series III, 109".....	RNA1033	\$ 78.50



Brake Fluid, Land Rover, Suitable for all

Brake Fluid, Girling, TRW, 1 litre (33oz).....	GBF4100	\$ 13.60
Brake Fluid, Girling, TRW, 500ml (16.9oz).....	GBF4500	\$ 7.45

Tent Triumphant

continued



Continued from page 19

Next up, we hit the hot trail to Monument, Oregon. Our drive took us through the John Day Fossil Beds, famous for their paleontology and geology, and the picture-worthy Painted Hills. Swinging north, we passed the fruit tree orchards of Kimberly (my kids think I should run for mayor) into the ranch lands of Monument. We parked the Rover in an empty pole barn, thankful for the shade on the searing hot Fourth of July weekend. By now tent set up proved a cinch and minutes later we basked in the cool of the John Day River. When night arrived, we climbed up into bed watching fireworks blaze trails in the sky. A cool finally settled in as crickets began their chirping.

We slept snug as bugs in a rug, content to give the kids another year or two in the roof top tent before we boot them to the ground annex. They certainly view our Land Rover trips through their own set of lenses; occasionally our priorities clash. Tent take down provides a good example! Sometimes they've bunched up the bedding like a puff ball, making battening down the hatches challenging. Other times the little rovers compete to see who climbs up on the Disco to help Jason strap stuff down. Some days arguing competes with tent takedown, slowing down everything. We're working on our *trail'tudes*.

As the end of summer approached we geared up for our annual trip with the Pacific Coast Rover Club. Meeting up with fellow rovers in Rome, OR, we headed for the Owyhee Canyonlands in a corner of the state where Idaho, Nevada and Oregon meet. The destination is Three Forks Hot Springs which remains pristine and inaccessible for most. Primitive roads descend steep and rocky paths. Help lies many miles away, but we came prepared as a convoy. We caravanned down the canyon and spent two blissful days hot springing and talking shop. We had rovered into an ever-changing light that bounced off canyon walls.

A few days later, we reluctantly turned the compass towards home. I lay awake that night, anxious about getting out of the canyon. The Discovery sits top heavy these days with the tent, fuel, water, and storage bin up on the roof top rack. At one point while driving out, I can't see the road in front of us anymore. We are angled, with only a view of the sky, except for the sheer drop off out the driver's side window. My insides shuddered, but we made it up and out, just as club members had assured me. We took new memories with us, but also hoped we taught our kids how to thoughtfully and carefully explore a world that remains unknown to many. Sure, some days the trail is just plain trying (with our without kids), but most trail days are terrific and there is no place our family would rather be.

Six months after installing the tent, we are happier than ever with our decision. The tent elevated (pardon the pun) our Rover excursions and ultimately enabled some wonderful memories. What do we like most about the tent? Our 40+ year-old backs now rest firmly on 3" of cushy foam mattress. *Achy breaky backs be gone*. Second, our gear no longer bumps and dumps all over dusty roads when we open the rear door. This is nice; really, really nice. Lastly, the tent saves us morning take down time. When traveling with the club, the morning pull out time is usually 8 am, and we routinely run last in the readiness cohort. With four people in the Disco, the morning prep and stow time simply takes longer, no matter how many gears we have engaged. Yet with our roof top tent, we managed to be the first ready more than once this summer. That's progress, people!

Ironically, two extended family members bought Airstream trailers this past summer. Airstreams offer sleek, sophisticated, first class accommodations. It's tempting to be jealous, but our roof tent allows us to visit places far off the beaten path. Airstreams do not go down copper colored canyons. We should have bought the tent and racking years ago, but there's no time to lament that now... we are too busy enjoying it! 

[You can follow Kim's writing at
<http://themountainishigh.blogspot.com> -ed.]

Engine Air Filters



Defender NAS 90,110 V8, Genuine	RNF950	\$ 14.95
Defender NAS 90,110 V8, ProLine.....	PLF950	\$ 6.95
V8 Carburetor.....	RNL394	\$ 69.22
200 Tdi Diesel, Genuine.....	RNH382	\$ 39.95
200 Tdi Diesel, ProLine.....	PLH382	\$ 21.95
300 Tdi Diesel, Genuine.....	RNH383	\$ 34.95
300 Tdi Diesel, ProLine.....	PLH383	\$ 12.95
Td5 Diesel, Genuine.....	RNF147	\$ 19.95
2.4 TDCi Diesel, Genuine.....	RNI725	\$ 59.95
2.4 TDCi Diesel, ProLine.....	PLI725	\$ 25.95
4 Cyl, 2.5 Defender, Genuine.....	RNL213	\$ 31.26
V8 Discovery I 1994-1999, Genuine	RNF010	\$ 11.95
V8 Discovery II 2000-2004, Genuine	RNF147	\$ 19.95
V8 Range Rover Classic 1974-1995		
1974-1985, (2 req), Genuine.....	RNF012	\$ 11.95
1986-1994, Genuine.....	RNF950	\$ 14.95
1986-1994, ProLine.....	PLF950	\$ 6.95
RRC 1995, Genuine.....	RNF010	\$ 11.95
V8 Range Rover P38A 1995-2002 1995-1997, Genuine.....	RNF011	\$ 19.95
V8 RR P38A Bosch '99-02, Gems '97-98 #WA385949 on, Genuine.....	RNF147	\$ 19.95
4.4, 4.2 Litre Range Rover L322 2003-2010		
2003-2005, 4.4 Litre, Genuine.....	RNI335	\$ 63.48
2003-2005, 4.4 Litre, ProLine.....	PLI335	\$ 37.95
2006-2010, 4.4 NA, 4.2 Litre Supercharged, Genuine.....	RNI548	\$ 50.67
2006-2010, 4.4 NA, 4.2 Litre Supercharged, ProLine.....	PLI548	\$ 29.95
V8, V6 LR3 2004-2009, Genuine	RNI346	\$ 34.95
LR3, L322 Air Filter Element, ProLine.....	PLI346	\$ 17.95
LR2 2008-2010, Genuine	RNI719	\$ 29.95

Genuine Pollen Air Filters

Range Rover L322 2002-2010, Genuine	RNI392	\$ 54.95
Range Rover P38A 1996-2002, Genuine.....	RND208	\$ 34.95
Range Rover Classic, Genuine	RNN718	\$ 9.75
LR2, Genuine	RNI723	\$ 29.95
LR3 2004-2009, Genuine	RNI353	\$ 64.95
LR3 & L320, Genuine.....	RNI352	\$ 48.26

Bonnet Release Cables

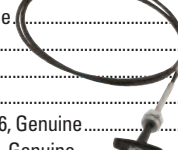

Range Rover Classic & Discovery, ProLine.....	PLI758	\$ 18.95
Range Rover Classic, 1984-'95, Genuine.....	RNN008	\$ 20.59
Discovery I, Late, Genuine.....	RNN958	\$ 35.95
Discovery II, Genuine.....	RNN957	\$ 44.95
Defender 90, 110, 1995-'96, up to TA977536, Genuine.....	RNL167	\$ 39.95
Defender 90, 110, 1996 from TA977537-'98, Genuine.....	RNC843	\$ 28.95
Defender 90, 110, 1999-'01, Genuine.....	RNL225	\$ 46.43
Defender 90, 110, 2002-'06, Cable Only, Genuine.....	RNH749	\$ 15.55
Defender 90, 110, ProLine.....	PLH749	\$ 14.95
Cable Bonnet Release, Range Rover 4.0, 4.6, Genuine	RNQ616	\$ 42.95
Release Lever, Range Rover 4.0, 4.6, Genuine	RNQ615	\$ 34.95
Cable Bonnet Release, Discovery I Mid 1995 to mid 1996, Genuine	RNL957	\$ 27.10
Cable Bonnet Release, Discovery II.....	RNN970	\$ 29.26
Cable Assembly Bonnet Release, L322 LHD, Genuine.....	RNI364	\$ 39.78

Automatic Transmission Service Kits

Includes filter, pan gasket and O-rings



Discovery I, II, Range Rover Classic, Range Rover P38A, 1997 Defender.....		
ZF Trans Filter Kit, 1987-2004, Genuine	RNK312	\$ 138.50
ZF Trans Filter Service Kit, 1987-2004, ProLine.....	PLK312	\$ 27.50

Genuine Hub Seal Kits

Includes Genuine hub seal, hub gasket, hub seal race and locker for hub nut.



Series II, IIA, & III (4 req), Genuine	RNK552	\$ 28.50
Defender 90/110 1993-1997 (4 req), Genuine	RNK5623	\$ 11.99
Hub Seal Kit Front Spindle, Defender 110	RNK5624	\$ 11.99
Hub Seal Kit Rear Spindle, Defender 110.....	RNK5625	\$ 44.99
Discovery I 1994-1999 Hub Seal Kit (4 req), Genuine	RNK5623	\$ 11.99
Range Rover Classic		
1987-'89, Hub Seal Kit (4 req), Genuine.....	RNK5621	\$ 39.99
1990-'92, Hub Seal Kit (4 req), Genuine.....	RNK5622	\$ 11.99
1993-'95, Hub Seal Kit (4 req), Genuine.....	RNK5623	\$ 11.99

Oil Filters

V8 Range Rover Classic, Range Rover P38A, V8 Discovery I & II, Defender 2.5, 3.9, 4.0 petrol, 2.5 diesel, 200, 300 Tdi,



Genuine.....	RNF001	\$ 12.99
ProLine.....	PLF001	\$ 6.29
V8, Tdi, 4 Cyl, 2.5L Extra Capacity, ProLine.....	PLI775	\$ 12.95
V8 Range Rover, L322, 2003-2005 w/ BMW engine, Genuine	RNI367	\$ 14.66
V8 Range Rover, L322, 2003-2005 w/BMW engine, ProLine.....	PLI367	\$ 12.99
V8 4.3 litre, 4.4 litre LR3, LR4, Range Rover, 2005 on, Genuine	RNH968	\$ 19.50
V8 4.3 litre, 4.4 litre LR3, LR4, Range Rover, 2005 on, ProLine	PLH968	\$ 7.95
V8 5.0 litre, RR, RR Sport, LR4, Genuine	RNN807	\$ 35.95
V8, 101 Forward Control, Genuine	RND503	\$ 30.78
V6 LR3, Genuine	RNH969	\$ 9.95
V6 LR3 & LR4 with Engine Oil Cooler, Genuine.....	RNL138	\$ 22.19
V6 LR3 & LR4 with Engine Oil Cooler, ProLine.....	PLL138	\$ 9.95
6 Cylinder LR2, 2008-2010, Genuine	RNI720	\$ 12.95
6 Cylinder 2.6 litre NADA 109", petrol, Genuine.....	RNE589	\$ 7.99
6 Cylinder 2.6 litre NADA 109", petrol, ProLine.....	PLE589	\$ 10.69
6 Cylinder 2.5 litre Freelander, petrol, Genuine.....	RND504	\$ 9.95
5 Cylinder 2.5 litre Td5 diesel, engine oil, Genuine	RND269	\$ 12.50
5 Cylinder 2.5 litre Td5 diesel, engine oil, ProLine.....	PLD269	\$ 7.95
5 Cylinder 2.5 litre Td5, Centrifuge element, Genuine.....	RNH251	\$ 29.95
4 Cylinder 2.3, 2.5 litre Defender 90/110, petrol, Genuine	RNF001	\$ 12.99
4 Cylinder 2.3, 2.5 litre Defender 90/110, petrol, ProLine	PLF001	\$ 6.29
4 Cylinder 2.4 TDCi 2007-2010, Genuine.....	RNI726	\$ 15.95
4 Cylinder 2.4 TDCi 2007-2010, ProLine.....	PLI726	\$ 10.95
4 Cylinder 2.5, 2.5 turbo, 200 Tdi, 300 Tdi diesel, Genuine.....	RNF001	\$ 12.99
4 Cylinder 2.5, 2.5 turbo, 200 Tdi, 300 Tdi diesel, ProLine.....	PLF001	\$ 6.29
4 Cyl 2.25 litre Ser IIA, III, petrol / diesel, 5.5" canister, Genuine.....	RNE590	\$ 9.95
4 Cyl 2.25 litre Ser IIA, III, petrol / diesel, 5.5" canister, ProLine.....	PLE590	\$ 6.95
4 Cyl 2.25 litre Ser IIA, III, petrol / diesel, 7.5" canister, Genuine.....	RNE591	\$ 8.50
4 Cyl 2.25 litre Ser IIA, III, petrol / diesel, 7.5" canister, ProLine.....	PLE591	\$ 8.75
4 Cyl 2.0 litre Ser I, petrol, Genuine.....	RNE589	\$ 7.99

Gaskets & Head Gasket Sets

Includes all gaskets and seals to overhaul your cylinder head(s).

V8, 3.5 Steel Head Gasket & Valve Cover Gasket, ProLine	PLM015	\$ 69.00
V8, 3.9, 4.0, 4.2 litre, Latest OEM upgrade kit with composite head gasket and rubber valve cover gaskets, ProLine	PLM083	\$ 98.90
V8, 3.9, 4.0, 4.2 litre, Premium Cylinder Head Gasket Set, ProLine	PLM083A	\$ 199.00
6 Cylinder 2.6 Petrol, ProLine	PLE602	\$ 49.99
4 Cylinder 2.25 Diesel, ProLine	PLF309	\$ 29.50
4 Cylinder 300 Tdi, ProLine.....	PLH701	\$ 99.50
Head Gasket, 4 Cylinder 2.25L Diesel, Genuine	RNC993	\$ 69.84
Head Gasket, 4 Cylinder 2.25L Diesel, ProLine.....	PLC993	\$ 29.95
Head Gasket, 4 Cylinder 2.25, 2.5L Petrol, Genuine.....	RNC969	\$ 44.95
Head Gasket, 4 Cylinder 2.25, 2.5L Petrol, ProLine.....	PLC969	\$ 29.95
Head Gasket, V8 3.9, 4.0, 4.6L Fibre Type, Genuine.....	RNM012	\$ 69.95
Head Gasket, V8 3.9, 4.0, 4.6L Fibre Type, ProLine.....	PLM012	\$ 19.99
Head Gasket, 6 Cylinder 2.6 L, Genuine.....	RNF296	\$ 49.24
Head Gasket, 4 Cylinder 300 Tdi, 1 Hole 1.37mm, Genuine.....	RNH704	\$ 98.95
Head Gasket, 4 Cylinder 200, 300 Tdi, 1 Hole 1.37mm, ProLine.....	PLH704	\$ 36.75
Head Gasket, 4 Cylinder 300 Tdi 2 Hole 1.48mm, Genuine.....	RNH705	\$ 90.55
Head Gasket, 4 Cylinder 200, 300 Tdi 2 Hole 1.48mm, ProLine.....	PLH705	\$ 36.75
Head Gasket, 4 Cylinder 300 Tdi 3 Hole 1.59mm, Genuine.....	RNH706	\$ 78.94
Head Gasket, 4 cylinder 200, 300 Tdi 3 Hole 1.59mm, ProLine.....	PLH706	\$ 36.75
Head Gasket, 4 Cylinder 300 Tdi 1.69mm Late Style, Genuine.....	RNH707	\$ 78.96
Head Gasket, 4 Cylinder 200, 300 Tdi 1.69 for Res, ProLine.....	PLH707	\$ 36.75

Block Gasket Set Inc. gaskets, sealing washers used in block and front cover.

All V8 does not include crank shaft oil seals, ProLine.....	PLF311	\$ 29.59
4 Cylinder 300 Tdi , does not include crank shaft oil seals, ProLine.....	PLH702	\$ 49.50

Full Engine Gasket Sets Includes all gaskets and seals to overhaul your entire engine.



4 Cylinder 2.25 Petrol, ProLine	PLF308	\$ 39.99	
4 Cylinder 2.25 Diesel, ProLine	PLK0134	PLC239	\$ 29.80
4 Cylinder 200 Tdi, ProLine.....	PLH703	\$ 45.50	
Td5 Valve Cover Gasket, Genuine	RNL309	\$ 69.95	
Cylinder Head Bolt Kit, V8 Petrol, Genuine	RNK0134	\$ 179.00	
Cylinder Head Bolt Kit, V8 Petrol, ProLine.....	PLK0134	\$ 39.00	

Fuel Filters

Series II, IIA, III 1959-1976

Inline filter with Quick Clamp

Fittings, that can be adapted to

any 5/16" fuel line, ProLine RFF111 \$ 6.99

Series III 1974 on, 2.25 litre petrol, canister type, Genuine..... RNE235 \$ 5.90

Defender 90/110 1993-1997

V8 inline with threaded fittings, Genuine RNF861 \$ 25.95

V8 inline with threaded fittings, ProLine..... PLF861 \$ 5.95

2.25, 2.5 petrol, inline w/threaded fittings, ProLine PLC632 \$ 5.95

2.25, 2.5 petrol, inline, splice in, ProLine RFF111 \$ 6.99

2.25, 2.5 NA, 2.5 turbo diesel, Genuine RNC745 \$ 9.95

200, 300Tdi Fuel Filter-diesel, Genuine RNF862 \$ 24.50

200, 300Tdi Fuel Filter-diesel, ProLine PLF862 \$ 9.95

Td5, Fuel Filter, Genuine RND270 \$ 69.95

Td5, Fuel Filter, ProLine..... PLD270 \$ 29.95

2.4 TDCi, 2007-2013, Genuine..... RNI724 \$ 62.50

2.4 TDCi, 2007-2013, ProLine..... PLI724 \$ 39.95

Filter Fuel Tank Draw Tube, Defender..... RNQ617 \$ 12.70

Discovery I 1994-1999

V8, threaded both ends, Genuine..... RNF861 \$ 25.95

V8 inline with threaded fittings, ProLine..... PLF861 \$ 5.95

Range Rover Classic 1987-1995

Fuel Filter Update Kit (required for early V8 Range Rover up to

VIN #LA464553), Genuine..... RNF133 \$ 98.95

Range Rover Classic V8 1987-1990, fuel filter (up to

VIN #LA464553 w/out update kit) RNF025 \$ 14.99

Range Rover Classic V8 1987-1995 (threaded both ends), Genuine.. RNF861 \$ 25.95

Range Rover Classic V8 1987-1995, ProLine..... PLF861 \$ 5.95

Range Rover L322 2003-2005, Genuine RNI371 \$ 84.95



Defender Locking Vented, European RNL361

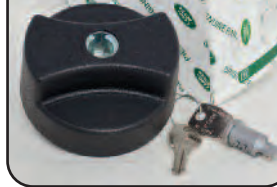

Discovery I, Defender RNF137

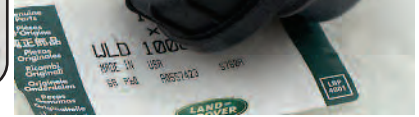

Fuel Caps

Discovery I, Defender, Genuine RNF137 \$ 39.95

Discovery I, Defender, ProLine PLF137 \$ 12.99

Discovery I, II, NAS Defender, Genuine RNF143 \$ 34.90

Defender, Locking Vented, European, Genuine RNL361 \$ 54.95

Defender, Locking Vented, European, ProLine PLL361 \$ 21.90

Defender, Non-Locking Vented Fuel Cap, Genuine RNL222 \$ 39.95

Defender, Locking NAS Fuel Cap, Genuine RNE247 \$ 39.90

Defender, Locking NAS Fuel Cap, ProLine PLE247 \$ 16.50

Discovery II, RRP38A V-8, Genuine RNN294 \$ 44.95

Series II & IIA, Fuel Cap 3 Prong, Early Type, Genuine RNB651 \$ 79.95

Series II & IIA, ProLine PLC168 \$ 32.95

Series III, ProLine..... RNN294 PLE406 \$ 8.50

Series Fuel Cap, 2 prong, ProLine..... PLC168 \$ 32.95

Series Fuel Cap, ex-MoD & Auxilliary Tank..... PLC449 \$ 89.95

LR4, Range Rover Sport L320 Fuel Cap..... RNS558 \$ 27.33



'tis the season



Waxoyl I20-4 Rust Inhibitor

Clear wax also good for general waterproof lubrication. 500 ml aerosol.

RNW5004 \$ 15.99



Waxoyl Hardwax Underbody

Black undercoat wax for protecting your chassis and floors. 500 ml aerosol.

RNW5006 \$ 15.99



Professional Starter Kit

Everything you need to perform a professional rust proof application.

Kit includes; 5 Liter underbody hardwax, 5 liter interior cavity wax, 2 professional application guns with two flexible wands.

WAX2 \$ 498.59



Learn about Waxoyl's superior corrosion protection and watch our application videos.



www.waxoyl-usa.com

Mechanical Fuel Pumps

Series II, IIA, III gasket included

2.25 Litre, Petrol, ProLine	PLC349	\$ 39.50
2.25 Litre, Diesel, ProLine	PLF299	\$ 59.98
Defender		
200 Tdi diesel, ProLine	PLI739	\$ 32.68
300 Tdi diesel, Genuine	RN1695	\$ 215.95
300 Tdi diesel, ProLine	PLI695	\$ 48.50

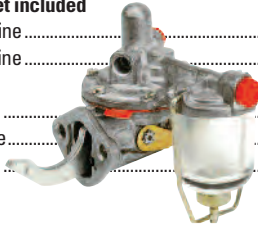

Fuel Tanks



Series 88" and 109" Regular, Petrol & Diesel, ProLine	PLC362	\$ 199.00
Series III 109", Rear Steel Fuel Tank, ProLine	PLH650	\$ 264.00
Fuel Sender for PLH650, ProLine	PLH652	\$ 47.50
Range Rover Classic 1971-1985 style, ProLine	PLH515	\$ 329.00
Defender 110 NAS, Range Rover Classic 1987-1991, ProLine	PLE114	\$ 199.00
Cradle for PLE114, ProLine	PLE116	\$ 79.50
Locking ring for sender, Series III, Defender 110, RRC, Genuine RNC886		\$ 8.95
Sealing ring for sender, Series III, Defender 110, RRC, Genuine RNC887		\$ 5.95
Defender 110 Diesel up to 1999, Rear Steel Fuel Tank	PLN180	\$ 239.00
Defender 90, Side Mount Fuel Tank	PLI135	\$ 295.00

Fuel Pumps, Sending Units

Series IIA & III 2.25 Diesel, Fuel Pump, Genuine	RNF299	\$ 354.35
Series IIA & III 2.25 Diesel, Fuel Pump, ProLine	PLF299	\$ 59.98
Fuel Sender, Series 109 SW, Positive Ground, ProLine	PLC750	\$ 129.00
Fuel Sender, Series IIA & III Petrol, NEG Earth, Forward Tank	RNE494	\$ 229.95
Range Rover Classic 1987-1990, Fuel Pump, ProLine	PLF131	\$ 98.20
Range Rover Classic up to LA464553, OEM Fuel Pump, ProLine	PLF131A	\$ 199.00
Range Rover Classic 1991-1995, Fuel Pump, Genuine	RNF132	\$ 369.95
Range Rover Classic 1991-1995, Fuel Pump, ProLine	PLF132	\$ 99.50
Fuel Sender, Range Rover Classic, Genuine	RND035	\$ POA
Fuel Sender, Range Rover Classic Early, ProLine	PLI292	\$ 49.95
Defender 90, 1994-1997, Rear Tank NAS, Genuine	RNF131	\$ 396.95
Defender 90, 1984-1993, Side Tank, ProLine	PLI774	\$ 42.90
Defender V8, Fuel Pump External	RNL678	\$ 243.17
Defender 90/110, Fuel Pump, Side Tank Petrol	PLL819	\$ 249.95
Defender 90 Td5, Fuel Pump Tank Unit, Genuine	RNI296	\$ 704.92
Defender 90 Td5, Fuel Pump tank Unit, ProLine	PLI296	\$ 198.00
Defender 110 NAS V8 fuel pump, ProLine	PLF131	\$ 98.20
Defender 110 NAS OEM Fuel Pump with steel fuel tank, ProLine	PLF131A	\$ 199.00
Defender 110 Rear Tank, Fuel Pump Assy Low Press	PLL768	\$ 59.95
Defender 110, Sending unit up to 1998, Genuine	RNC854	\$ 149.95
Defender 300 Tdi, Fuel Pump, Genuine	RN1695	\$ 215.95
Defender 300 Tdi, Fuel Pump, ProLine	PLI695	\$ 48.50
Defender 110 TD5, Fuel Pump & Sending Unit, Genuine	RNL876	\$ 859.95
Defender 110 TD5, Fuel Pump & Sending Unit, ProLine	PLL876	\$ 189.95
Fuel Sender, Defender 110 Diesel, Genuine	RNL631	\$ 169.95
Fuel Sender, Defender 110 Diesel, ProLine	PLL631	\$ 49.95
Fuel Sender, Defender 110 Diesel 4 CYL to 2007	PLH662	\$ 51.45
Discovery I 1994-1997, Fuel Pump, Genuine	RNF132	\$ 369.95
Discovery I 1994-1997, Fuel Pump, ProLine	PLF132	\$ 99.50
Discovery I 1997-1999, from VA737154, Fuel Pump, Genuine	RNF148	\$ 791.29
Discovery I 1997-1999, from VA737154, Fuel Pump, ProLine	PLF148	\$ 369.00
Discovery II w/black connector, Fuel Pump	RNH295	\$ 499.95
Discovery II w/o black connector, Fuel Pump	RNE009	\$ 449.95
Range Rover P38A 1995-97, FUEL PUMP - PETROL	RNH083	\$ 570.04
Range Rover P38A 1999+ Fuel Pump/Sender	RND264	\$ 717.47
Frelander, Fuel Pump & Gasket, Genuine	RNQ662	\$ 510.96

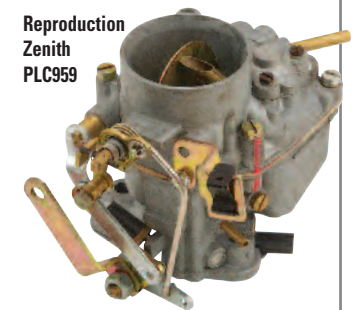

Replacement Carburetors

Weber, Series IIA & III 2.25 Litre	341CH	\$ 259.00
Reproduction Zenith, Series IIA & III 2.25 Litre	PLC959	\$ 149.00
Adapter Ring Zenith Carb, from Intake elbow to carb, ProLine	PLC375	\$ 7.95

Carburetor Rebuild Kits

Zenith 1967-1983 Series IIA-III, 2.25 Rebuild Kit, ProLine	PLC622	\$ 24.95
Zenith Carburetor Rebuild Kit, Genuine	RNC622	\$ 279.95
Zenith Carburetor Gasket Set, Genuine	RNC623	\$ 28.84
Weber 341CH Rebuild kit, ProLine	WEBERKIT	\$ 29.60
Solex 1959-1966 Series II-IIA Rebuild kit, ProLine	PLC180	\$ 31.49



NEW Series IIA & III Fuel Lines

FUEL LINE PUMP-CARB ADAPTER SERIES IIA-III, Fuel Pump to Zenith	PLC522	\$ 40.95
FUEL PIPE FORWARD TANK TO FUEL PUMP SERIES II, IIA & III	PLC366	\$ 48.95
FUEL LINE REAR TANK-FUEL PUMP SERIES IIA & III 109" S.W.	PLC367	\$ 69.95
FUEL PIPE PUMP TO CARB SERIES II-IIA W/SOLEX CARB, Fuel Tank to Fuel Pump 88 & 109 Regular	PLC382	\$ 43.95
FUEL PIPE PUMP-ZENITH CARB SERIES IIA	PLQ643	\$ 24.95
ADAPTOR FUEL LINE- CARB SERIES IIA & III, Genuine	RNC521	\$ 7.16
ADAPTOR FUEL LINE- CARB SERIES IIA & III, ProLine	PLC521	\$ 5.99



Discovery II V8
RNK9302



Defender 300 TDI
RNK0001

SAVE!

Basic Engine Service Kits

V8 Kits Include: Oil Filter, Oil sump drain washer

V8 - Range Rover, Defender	RNK9300	\$ 17.50
V8 - Discovery I	RNK9301	\$ 17.55
V8 - Discovery II	RNK9302	\$ 15.49

Defender 300 TDI Kit includes: Air Filter, Oil Filter

and Fuel Filter 300 TDI Filter Change Kit	RNK0001	\$ 42.50
---	---------	----------

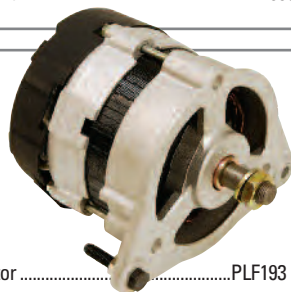

PLF193

NEW Alternators & Generator

Series III 12 Volt Lucas Style Alternator PLF193 \$ 99.50

Series Generator, Original Equipment, all 2.25 Litre petrol and diesel engines from 1959-1971 RNE647 \$ 143.00

Defender 2.5 NA Diesel, 2.5 Turbo Diesel, 200 TDI, 2.5 Petrol, 3.5 V8 PLD498 \$ 199.00

300 TDI, 65 AMP, Defender 90, 110, Genuine RNH259 \$ 579.95

300 TDI, 65 AMP, Defender 90, 110, ProLine PLH259 \$ 169.00

3.9 Litre V8, Defender 90/110 NAS, ProLine PLE846 \$ 219.24

4.0 Litre V8, Defender 90 NAS 1997, ProLine PLE870 \$ 299.95

4.0 Litre V8, Defender 90 NAS 1997, 100 amp, 7 groove, rebuilt PLE866A \$ 279.95

Td5, Alternator Assembly, ProLine PLH260 \$ 699.95

Discovery I 4.0 litre 1996-1999 PLE870 \$ 299.95

Discovery I 3.9 litre, 1994-1995, 67mm, 7 groove pulley for serp belt PLE863 \$ 299.95

Discovery I 1996 on, 100 amp, 7 groove, rebuilt PLE866A \$ 279.95

Discovery II, 130 amp Bosch PLH261 \$ 329.95

Range Rover Classic, 1987-'88 PLD498 \$ 199.00

Range Rover Classic, 1993-'94, 100 amp 4 groove pulley PLE846 \$ 219.24

RRC, from SA647650, 52mm, 7 groove pulley for serp belt PLE870 \$ 299.95

Range Rover P38A from VA346795 to WA410481, 120 AMP, 52mm, 7 Groove Pulley PLE870 \$ 299.95



PLI533

2.25 & 2.6 L
Petrol
Hi-Torque
Starter
PLI029

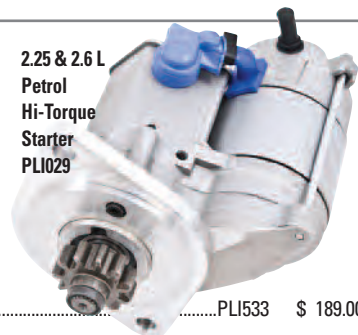

NEW Starter Motor Assemblies

V8 Early PLI533 \$ 189.00

V8 thru 2004, except Range Rover thru 2002 PLE867 \$ 219.00

2.25 & 2.6, Litre petrol, Hi-Torque, ProLine PLI029 \$ 299.50

2.25, Diesel PLF198 \$ 249.00

200 & 300 Tdi, High speed PLD294 \$ 499.00

Td5, Defender & Discovery, Genuine RNI728 \$ 566.51

Td5, Defender & Discovery, ProLine PLI728 \$ 359.00



RNK9330
1987-'90 Range Rover Classic
30K Mile Service Kit

Complete 30K Mile Engine Service Kits

Range Rover Classic

30K Mile Service Kit, Range Rover Classic 1987-'90 RNK9330 \$ 389.95

30K Mile Service Kit, Range Rover Classic 1991-'94 RNK9331 \$ 389.29

Discovery I

30K Mile Service Kit, Discovery I 1994-'95 Automatic RNK9332 \$ 339.99

30K Mile Service Kit, Discovery I Standard Transmission RNK9333 \$ 205.27



RNK9337

Improve your mpg!

Engine Ignition Service Kits

Ignition Tune-Up Kit, 3.5, 3.9, 4.2 L V8, RRC, Defender RNK9335 \$ 219.00

Ignition Tune-Up Kit, Range Rover Classic, 1995 RNK9337 \$ 259.89

Ignition Tune-Up Kit, V8, 3.9 L, 1994-'95 Discovery I RNK9336 \$ 157.45

Ignition Tune-Up Kit, V8, 4.0 L, 1996-'99 Discovery I RNK9339 \$ 169.98

Ignition Tune-Up Kit, V8, 1995-'98, RR P38A RNK9340 \$ 139.00

Ignition Tune-Up Kit, V8, 1999 on, RR P38A, Discovery II RNK9341 \$ 289.00

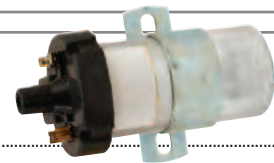

RNE509

Ignition Coil

4 Cylinder and 6 Cylinder RNE522 \$ 149.55

4 Cylinder and 6 Cylinder PLE522 \$ 29.00

3.9 litre and 4.2 litre

Bosch ignition coil for EFI RNE509 \$ 199.95

Ignition Coil 3.9L Bosch, ProLine PLE509 \$ 99.95

4.0, 4.6 ltr P38A, Discovery II, individual unit only RNI110 \$ 89.95

4.0, 4.6 ltr P38A, Discovery II, Coil Pack Assembly complete RND523 \$ 339.96

Coil Pack Assembly, 4.0, 4.6 Gems P38A, Discovery II PLD310 \$ 219.95

Spark Plugs

RRC, Discovery I, Defender, Range Rover P38A, Genuine RNI003 \$ 6.49

RRC, Discovery I, Defender, Range Rover P38A, NGK PLI003 \$ 2.84

RRC, Discovery I, Defender, Range Rover P38A, Champion PLI003C \$ 3.99

Platinum - Discovery II, Range Rover P38A, Bosch RNI034 \$ 15.95

2.25 Petrol 8:1 RNE630 \$ 2.59

2.25 Petrol 7:1 RNE619 \$ 3.99

2.6 litre RNE631 \$ 3.99

Range Rover L322, '03-'05 RNN079 \$ 34.95

Range Rover L322, '06 on RNI360 \$ 12.95

Range Rover, Early RoW, point ignition, up to engine suffix "F" RNI305 \$ 7.35





RNI019



PLI019



PLE143

NEW Complete Distributor Assemblies

V8 EFI Distributor Assembly 3.5, 3.9, 4.2, Genuine	RNI019	\$1018.37
V8 EFI Distributor Assembly 3.5, 3.9, 4.2, ProLine	PLI019	\$ 199.00
V8 Distributor Rebuild Kit, Genuine	RNI012	\$ 89.95
V8 Distributor Rebuild Kit, ProLine	PLI012	\$ 44.95
Series II, IIA & III 2.25L 4 Cylinder models, ProLine	PLE143	\$ 119.00
V8 Module Amplifier, 3 Pin, ProLine	PLI024	\$ 73.45
V8 Vacuum Unit, ProLine	PLI009	\$ 79.45

Ignition Condenser

Series 2.25 litre

Early Lucas	RNE613	\$ 6.95
Late Lucas, red or blue point sets	RNF229	\$ 5.23
Ducellier type	PLF228	\$ 2.42
2.6 litre 6 Cylinder, 3.5 litre V8	RNE613	\$ 6.95

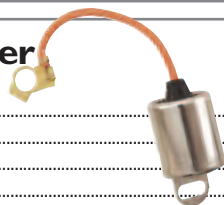

Ignition Point Sets

4 Cylinder and 6 Cylinder Early Lucas Points

Condenser and low tension lead ends slide over the round post and are "Sandwiched" between the points spring and plastic isolator. A single nut tightens these on the post.....RNE595 \$ POA

4 Cylinder Late Lucas (red)

Combination low tension / condenser lead clips onto the "Shepard Hook" end of the points spring.....RNE637 \$ 19.95
4 Cylinder Late Lucas (red), ProLine.....PLE637 \$ 3.99

4 Cylinder Late Lucas (blue)

Similar as preceding, but blue. Known as sliding points.....RNF232 \$ 19.99

4 Cylinder Ducellier

Two-piece points. Low tension lead attached by moving contact. Condenser mounted on outside of distributor.....PLF231 \$ 4.95

24 volt FFR (Fitted for Radio)

Points set Military 2.25 litre (not pictured).....RNF230 \$ 58.99

V8 3.5 Litre

Sliding point set.....PLI738 \$ 6.99
Non-sliding point set.....PLD074 \$ 11.95



RNE595



RNE637



RNF232



RNF231



PLI738



RND074

PLI006

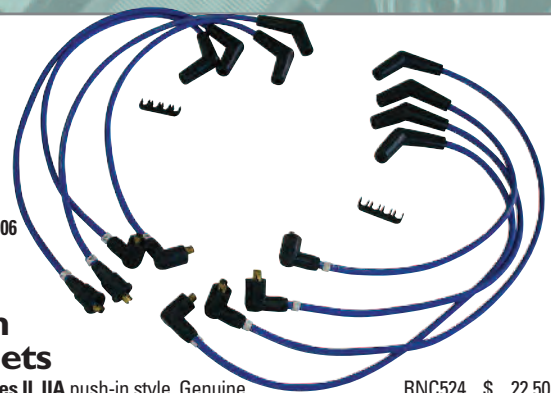

Ignition Wire Sets

4 Cylinder Series II, IIA push-in style, Genuine.....	RNC524	\$ 22.50
4 Cylinder Series III push-in style, Genuine.....	RNC960	\$ 74.95
4 Cylinder Series III push-in style, ProLine.....	PLC960	\$ 18.95
4 Cylinder Series III push-in style, Lucas.....	PLC960L	\$ 19.50
6 Cylinder, 2.6 ltr, Series III	RNC957	\$ 49.95
V8, 3.5, 3.9 litre, Genuine.....	RNI004	\$ 89.66
V8, 3.5, 3.9 litre, ProLine	PLI004	\$ 29.95
V8, 4.2 litre 1995 Range Rover Classic LWB, Genuine.....	RNI005	\$ 139.99
V8, Gems, 4.0 litre, 1995-1999, Discovery I, Range Rover P38A, Defender 4.0, Genuine	RNI006	\$ 128.50
V8, Gems, 4.0 litre, 1995-1999, Discovery I, Range Rover P38A, Defender 4.0, ProLine.....	PLI006	\$ 49.50
V8, Bosch 1999-2004, Range Rover P38A, Discovery II, Genuine	RNI007	\$ 198.50
V8, Bosch 1999-2004, Range Rover P38A, Discovery II, ProLine.....	PLI007	\$ 43.50

Distributor Caps

Sold separately

1. 4 Cylinder Series II, IIA with screw-in wire ends, Genuine	RNC603	\$ 34.95
2. 4 Cylinder Series IIA, III Early Lucas, push-in, ProLine	PLC437	\$ 11.75
3. 4 Cylinder Late Lucas, Genuine.....	RNE596	\$ 19.99
4 Cylinder Late Lucas, ProLine	PLE596	\$ 6.90
4. 4 Cylinder Ducellier Type Cap, ProLine	PLF185	\$ 11.50
4 Cylinder Military 24 volt FFR, Genuine.....	RNC767	\$ 319.95
6 Cylinder, ProLine	PLC628	\$ 9.80
V8, Genuine	RNI001	\$ 59.98
V8, Lucas, ProLine	PLI001	\$ 18.50



1



2



3



4

Distributor Rotors

Sold separately

1,2. Early Lucas, ProLine	PLE633	\$ 5.95
3. Late Lucas, ProLine.....	PLE634	\$ 4.75
4. Ducellier Type Cap, Genuine	RNF186	\$ 8.95
6 Cylinder, Genuine.....	RNF178	\$ 4.79
V8, Genuine	RNI002	\$ 29.95
V8, ProLine.....	PLI002	\$ 8.50

Oxygen Sensors

Defender

3.9 V8, OBD1 front, 2 req, ProLine	PLE029	\$ 136.45
4.0 V8, OBD2 Heated, 4 required, front and rear, Genuine.....	RND292	\$ 339.34
4.0 V8, OBD2 Heated, 4 required, front and rear, ProLine	PLD292	\$ 129.95

Discovery I

3.9 V8, OBD1, 2 required, ProLine	PLE029	\$ 136.45
4.0 V8 w/AEL, OBD2 Heated, 4 required, front and rear, Genuine.....	RND292	\$ 339.34
4.0 V8 w/AEL, OBD2 Heated, 4 required, front and rear, ProLine	PLD292	\$ 129.95
4.0 V8 w/o AEL, OBD2, 4 required, front and rear, Genuine	RND290	\$ 389.95
4.0 V8 w/o AEL, OBD2, 4 required, front and rear, ProLine.....	PLD290	\$ 129.50

Discovery II

V8, OBD2, 2 required, front, Genuine	RNE910	\$ 269.95
V8, OBD2, 2 required, front, ProLine.....	PLE910	\$ 69.95
V8, OBD2, 2 required, rear, Genuine.....	RNE892	\$ 259.95
V8, OBD2, 2 required, rear, ProLine	PLE892	\$ 89.95

Range Rover Classic

3.5, 3.9, 4.2 litre V8, OBD1 front, 2 required, ProLine	PLE029	\$ 136.45
---	--------	-----------

Range Rover P38A

1995-'97 to VA350101, OBD2, 4 required, ProLine.....	PLD290	\$ 129.50
1997-'98 from VA350101 to WA410481, OBD2 Heated, 4 required, front and rear, Genuine.....	RND292	\$ 339.34
1997-'98 from VA350101 to WA410481, OBD2 Heated, 4 required, front and rear, ProLine	PLD292	\$ 129.95
1999-'02 from XA410482, OBD2, 2 required, rear, Genuine.....	RNE892	\$ 259.95
1999-'02 from XA410482, OBD2, 2 required, rear, ProLine	PLE892	\$ 89.95
1999-'02 from XA410482, OBD2, 2 required, front, Genuine	RNE893	\$ 269.95
Range Rover L322, rearward, Genuine	RNI334	\$ 344.76



Discovery II Hub Assembly with Sensor

Discovery II 1999-2004.

Includes bearings, ABS sensor.

Front hub assembly	PLD676	\$ 395.00
Rear hub assembly.....	PLD694	\$ 385.00

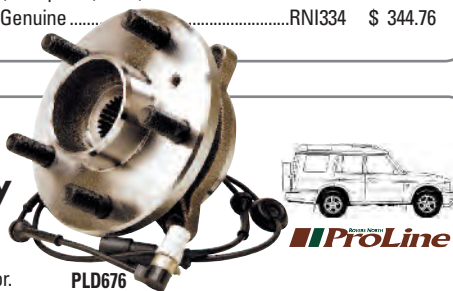

U-Joint Kits

Series II, IIA, III

Front & rear, 2 15/16" from cap top to cap top, Genuine	RNE598	\$ 59.95
Front & rear, 2 15/16" from cap top to cap top, ProLine.....	PLE598	\$ 24.95
Front & rear, 3 7/32" from cap top to cap top, Genuine	RNE604	\$ 79.85
Discovery I, Range Rover Classic, Front or rear, Genuine	RNF411	\$ 99.98
Discovery I, Range Rover Classic, Front or rear, ProLine	PLE598	\$ 24.95
Defender 90, Front, Genuine	RNF411	\$ 99.98
Defender 90, Front or Rear, ProLine	PLE598	\$ 24.95
Defender 90, Rear, Genuine.....	RNE611	\$ 79.58
Defender 110, Front or rear, Genuine.....	RNE611	\$ 79.58
Defender 110, Front or rear, ProLine	PLE598	\$ 24.95

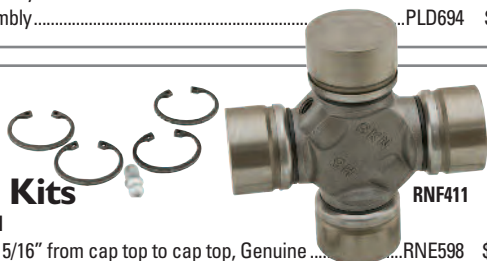

Rear Driveshaft Flex Couplers

Range Rover Classic 1995

Discovery I & II

Flex Coupler for rear drive shaft, with hardware, Genuine.....	RND196	\$ 139.95
Flex Coupler, with hardware, OEM, ProLine	PLD196	\$ 79.95

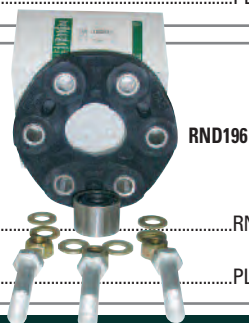

Drive Shafts

Discovery I Rear Drive Shaft Update Kit replaces Flex Coupler Drive Shaft with Twin U-Joint type. Includes new rear Drive Shaft and

4 bolt Differential Flange kit, ProLine.....	PLK4100	\$ 269.00
--	---------	-----------



New Drive Shaft Assemblies with U-Joints

Series II, IIA, III, front, 88 & 109, ProLine.....	PLF315	\$ 148.00
Series II, IIA, III 88, rear, ProLine.....	PLE189	\$ 178.45
Series II, IIA 109, rear, ProLine.....	PLF358	\$ 178.45
Defender 90 V8, rear, ProLine.....	PLE201	\$ 199.00
Defender 110, front, ProLine.....	PLF410	\$ 258.00
Defender 110, 4 Cyl up to 1999, rear, ProLine	PLE217	\$ 269.00
Discovery II, front, 1999-2004, ProLine	RND665HD	\$ 459.99
Discovery II, front, 2003-2004 4.6 litre, ProLine	RND665HD	\$ 459.99
Discovery I & Range Rover Classic 100 inch, rear, ProLine	PLD473	\$ 199.00

Thermostats

2.25, 2.6 Petrol and Diesel Series IIA-III

Thermostat 74 C / 165 F, Genuine	RNC276	\$ 59.95
Thermostat 74 C / 165 F, ProLine.....	PLC276	\$ 9.95
Thermostat 82 C / 179 F, Genuine	RNC580	\$ 59.95
Thermostat 82 C / 179 F, ProLine.....	PLC580	\$ 8.95
Thermostat, 2.6 Litre, Genuine	RNC421	\$ 16.10

V8 Discovery I, Range Rover Classic, Defender

Thermostat 82 C / 179 F, Genuine	RNH386	\$ 14.99
Thermostat 82 C / 179 F, ProLine.....	PLH386	\$ 4.74
Thermostat 88 C / 190 F, Genuine	RNC047	\$ 12.95
Thermostat 88 C / 190 F, ProLine.....	PLC047	\$ 5.95

2.5 NA Diesel Defender, Thermostat 75°C / 165 F.....

2.5 NA Diesel Defender, Thermostat 82°C / 179 F, Genuine.....	RNH386	\$ 14.99
2.5 NA Diesel Defender, Thermostat 82°C / 179 F, ProLine	PLH386	\$ 4.74
300 Tdi Thermostat, ProLine.....	PLL137	\$ 7.95
Td5 Thermostat assembly, 190 deg, Genuine	RND564	\$ 46.95
Td5 Thermostat assembly, 190 deg, ProLine	PLD564	\$ 29.85

Thermostat Assemblies

V6 Freelander Thermostat assembly	RNL472	\$ 108.51
---	--------	-----------

V8 Discovery II 1999-2004

Thermostat assembly, 190 deg, Genuine	RND564	\$ 46.95
Thermostat assembly, ProLine	PLD564	\$ 29.85
Thermostat assembly, Td5 (180 deg, fits NAS V8), Genuine.....	RNQ028	\$ 79.50

V8 Range Rover P38A 1995-2002

Thermostat assembly, Genuine	RND211	\$ 139.95
Thermostat assembly, ProLine	PLD211	\$ 49.86

V8 Range Rover L322 2003-2010

4.4tr. 2003-'05, BMW Engine, thermostat assembly, Genuine	RNJ993	\$ 159.95
4.4, 4.2ltr. Supercharged, 2006-'09 thermostat assembly, Genuine.....	RNJ330	\$ 46.95
4.4tr., O-ring seal, thermostat housing, Genuine	RNN217	\$ 5.66

Thermostat Gaskets 2.25 Petrol and Diesel Series IIA-III

Top thermostat gasket, ProLine.....	PLC245	\$ 0.83
Top O-ring seal, Genuine	RNC248	\$ 1.73
Bottom thermostat gasket, ProLine	RNB573	\$ 3.66
Side by-pass gasket, Genuine	RNC738	\$ 2.78
V8 Discovery I, RRC, Defender Thermostat gasket, Genuine.....	RNC046	\$ 3.59
2.5 NA Diesel Thermostat gasket, Genuine.....	RNH387	\$ 3.69
200Tdi Defender Thermostat, Genuine	RNL141	\$ 20.59
200Tdi Diesel Thermostat gasket, Genuine.....	RNH387	\$ 3.69
300Tdi Defender Thermostat, Genuine.....	RNL137	\$ 19.85

Thermostat Kits

2.25 Petrol Series IIA-III. Kits include o-ring, upper and lower gaskets and thermostat

Thermostat Kit 74 C / 165 F.....	RNK1574	\$ 55.95
Thermostat Kit 74 C / 165 F.....	PLK1574	\$ 12.99
Thermostat Kit 82 C / 179 F.....	RNK1582	\$ 57.50
Thermostat Kit 82 C / 179 F.....	PLK1582	\$ 14.99
Thermostat Kit V8, RRC '87-'95, Discovery I, Defender	RNK167	\$ 16.54

NEW Radiators

Discovery II
PLD495

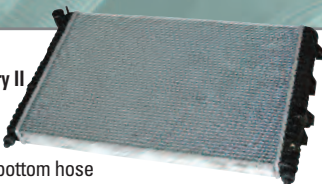

- 2.25 Litre, Series II-III 4 core style** radiator requires top hose RNC510 and bottom hose PLE407 when fitting to Series II-IIA, GenuineRNC513 \$ 675.96
- 2.25 Litre, Series II-III 4 core style** radiator requires top hose RNC510 and bottom hose PLE407 when fitting to Series II-IIA, ProLinePLC513 \$ 298.00
- 2.25 Litre, Series II-III 3 core style** radiator requires top hose RNC510 and bottom hose PLE407 when fitting to Series II-IIA, ProLinePLC513A \$ 298.00
- Discovery I 1994-1999** with automatic transmission, GenuineRNC062 \$ 899.00
- Discovery I 3.9 Litre V8, ProLinePLC019A \$ 399.00
- Plastic Fill Plug, Radiator, GenuinePLC019A \$ 5.25
- Brass Fill Plug, Radiator, ProLinePLC997 \$ 3.79
- Washer, For Brass or Plastic Fill Plug, GenuineRNC996 \$ 2.92
- Range Rover Classic 1987-1988**, Radiator, ProLinePLC020 \$ 459.00
- Range Rover Classic 1993-1995, Radiator, GenuineRNC062 \$ 899.00
- Range Rover Classic 1989-1995, Radiator, ProLinePLC019A \$ 399.00
- Plastic Fill Plug, Radiator, GenuineRNC997 \$ 5.25
- Brass Fill Plug, Radiator, ProLinePLC997 \$ 3.79
- Washer, For Plastic Fill Plug, GenuineRNC996 \$ 2.92
- Range Rover P38A** Radiator Assembly, 1995-'98, GenuineRND357 \$ 607.89
- Defender 1993-1997** NAS 90/110 V8 Radiator Assembly, Genuine...RNE130 \$ 799.95
- Defender Td5 w/EGR, GenuineRNH256 \$ 618.76
- Defender Td5 w/EGR, ProLinePLH256 \$ 279.95
- Defender 300 Tdi Radiator with intercooler, ProLinePLD500 \$ 548.00
- Defender 300 Tdi Radiator, ProLinePLH255 \$ 329.00
- Defender 200 Tdi Radiator, ProLinePLD496 \$ 269.00
- Defender 3.5L V8 twin carb, ProLinePLL885 \$ 249.95
- Discovery II 1999-2004** Radiator, ProLinePLD495 \$ 279.00
- Range Rover 2002** on L322 4.4 Litre, ProLinePLI516 \$ 369.00
- Radiator Assembly, 1999-'02.....PLI759 \$ 299.00



Radiator Hose Kits

We recommend only using genuine hoses when it's time to replace yours.

Don't settle for lower quality imitations. Includes: Genuine top and bottom radiator hoses, manifold jacket hoses, and all necessary clamps.



- Range Rover Classic 1989**, Radiator Hose Kit.....RNK1612 \$ 149.95
- Radiator Hose Kit, Range Rover Classic, 3.9L 1990-'94RNK1613 \$ 189.00
- Radiator Hose Kit, Range Rover Classic, 4.2L 1993-'94RNK1614 \$ 189.00
- Radiator Hose Kit, Range Rover Classic, 4.2L 1995.....RNK1617 \$ 199.00
- Range Rover P38A** Radiator Hose Kit, up to VIN XA430701.....RNK1619 \$ 399.00
- Range Rover P38A, Radiator Hose Kit, from VIN YA430702.....RNK1619A \$ 529.00
- Discovery 1995-'99**, Radiator Hose KitRNK1616 \$ 199.00
- Discovery I 1995-'99, w/EVAP Loss System, Radiator Hose Kit.....RNK1618 \$ 219.00

Coolant Expansion Tanks & Caps

Expansion Tanks

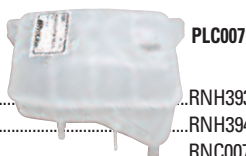

- Defender 3.9 Litre V8, 1993-95, GenuineRNH393 \$ 285.45
- Defender 4.0 Litre V8, 1997, GenuineRNH394 \$ 141.80
- RR Classic, 1990 on, Discovery I, GenuineRNC007 \$ 119.95
- RR Classic, 1990 on, Discovery I, ProLinePLC007 \$ 38.95
- Discovery II, RR P38A, Genuine.....RNI554 \$ 229.00
- Discovery II, RR P38A, ProLinePLI554 \$ 69.95
- CAP COOLANT EXPANSION TANK 15 PSI**
- RRC, DEFENDER & DISCOVERY I, GenuineRNC017 \$ 17.95
- CAP COOLANT EXPANSION TANK 15 PSI**
- RRC, DEFENDER & DISCOVERY I, ProLine.....PLC017 \$ 7.50
- CAP COOLANT RESERVOIR, P38A & DISCOVERY II**, Genuine.....RND344 \$ 29.95
- CAP COOLANT RESERVOIR, P38A & DISCOVERY II**, ProLine.....PLD344 \$ 14.88
- CAP COOLANT EXPANSION TANK DEFENDER & FREELANDER**RNL074 \$ 14.95
- CAP COOLANT OVERFLOW L322**RNQ647 \$ 40.45
- CAP FOR OVERFLOW TANK LR3, L322, L320**.....RNI359 \$ 10.25
- CAP FOR RADIATOR OR EXPANSION TANK -15PSI, 3.9L V8**RNC022 \$ 7.03
- CAP COOLANT OVERFLOW BOTTLE, SERIES IIA & III**RNC431 \$ 12.75
- CAP COOLANT OVERFLOW BOTTLE, SERIES IIA & III**PLC431 \$ 9.75



Stop Leaks!
Complete Cooling System Kits

We only recommend genuine hoses. There is a dramatic difference in quality!

Includes: Genuine radiator hoses, heater hoses, expansion tank hoses, thermostat, gasket and all necessary clamps.

- Range Rover Classic 1987-'88**, Cooling System Kit.....RNK1601 \$ 209.00
- Range Rover Classic 1989, Cooling System Kit.....RNK1602 \$ 241.44
- Range Rover Classic 1990-'94, Cooling System Kit.....RNK1603 \$ 299.00
- Range Rover Classic, 4.2L 1993-'94, Cooling System Kit.....RNK1604 \$ 319.00
- Range Rover Classic 1995, Cooling System Kit.....RNK1608 \$ 289.00
- Range Rover P38A**, Cooling System Kit, up to VIN XA30701.....RNK1610 \$ 579.00
- Range Rover P38A, Cooling System Kit, from VIN YA30702.....RNK1610A \$ 589.00
- Discovery I**, Cooling System Kit, w/A.E.L.....RNK1607 \$ 339.50
- Discovery I, Cooling System Kit, w/o A.E.L.....RNK1606 \$ 389.00
- Discovery II**, Cooling System Kit (shown above).....RNK1609 \$ 529.00

NEW Water Pumps with Gasket

- Series IIA, III 1961-1984**, 2.25 litre petrol, diesel, Genuine.....RNF334 \$ POA
- 2.25 litre petrol, diesel, ProLine.....PLF334 \$ 49.50
- Rebuild kit for 2.25 water pumps.....PLE587 \$ 34.95
- Series IIA, III 2.25 L Petrol, ex-MoD, ProLine with gasket**PLC348 \$ 96.29

Defender 90/110 1993 - 2006

- 1993-1995 NAS, Water Pump, GenuineRNC011 \$ 269.95
- 1993-1995 NAS, Water Pump, ProLine.....PLC011 \$ 89.00
- 1997 D90 NAS, Water Pump, GenuineRNC052 \$ 359.95
- 1997 D90 NAS, Water Pump, ProLine.....PLC052 \$ 79.95
- 200 Tdi diesel, Water Pump, GenuineRNH257 \$ 349.95
- 200 Tdi diesel, Water Pump, ProLine.....PLH257 \$ 89.00
- 300 Tdi diesel, Water Pump, GenuineRNH258 \$ 119.95
- 300 Tdi diesel, Water Pump, ProLine.....PLH258 \$ 39.95
- 4 Cylinder, Defender 90/110, Genuine.....RNI847 \$ 316.35
- 4 Cylinder, Defender 90/110, ProLine.....PLI847 \$ 149.50
- 4 Cylinder, Defender 2.25L w/o AC, GenuineRNF361 \$ 443.27
- 4 Cylinder, Defender 2.5L Non Viscous, GenuineRNI781 \$ 265.13
- 4 Cylinder, Defender 2.5L w/o AC, ProLine.....PLI781 \$ 89.32
- Td5 diesel, Water Pump, GenuineRNH360 \$ 184.95
- Td5 diesel, Water Pump, ProLine.....PLH360 \$ 69.95
- Discovery I 1994-1999**, Water Pump, GenuineRNC052 \$ 359.95
- Discovery I 1994-1999, Water Pump, ProLinePLC052 \$ 79.95
- Discovery I 200 Tdi, Water PumpRNN036 \$ 197.50
- Discovery II 2000-2002**, Water Pump, Genuine.....RNC052 \$ 359.95
- Discovery II 2000-2002, Water Pump, ProLinePLC052 \$ 79.95
- Range Rover Classic '87-1994**, Water Pump, GenuineRNC011 \$ 269.95
- Range Rover Classic '87-1994, Water Pump, ProLinePLC011 \$ 89.00
- Range Rover Classic '95, Water Pump, GenuineRNC052 \$ 359.95
- Range Rover Classic '95, Water Pump, ProLine.....PLC052 \$ 79.95
- Range Rover Classic V-8.....PLN716 \$ 123.95
- Range Rover Classic 200 Tdi, Water PumpRNN036 \$ 197.50
- Range Rover P38A '95-2002**, Water Pump, Genuine.....RNC052 \$ 359.95
- Range Rover P38A, '95-2002, Water Pump, ProLine.....PLC052 \$ 79.95
- LR3, L322 from '06 on, L320**, Water Pump w/Gasket, 4.4L AJ V8, Genuine.RNI973 \$ 248.95
- LR3, L322 from '06 on, L320, Water Pump w/Gasket, 4.4L AJ V8, ProLine .PLI973 \$ 99.50
- L322, Water Pump Assembly, 4.4L V8 DOHCPLI755 \$ 169.95
- Water Pump V-8 Viscous, GenuineRNL755 \$ 340.48
- Water Pump V-8 Viscous, ProLine.....PLL755 \$ 159.95
- Water Pump V-8 w/Salomon A.C., Genuine.....RNL645 \$ 242.00
- Water Pump V-8 Non Visco, GenuineRNL677 \$ 242.77

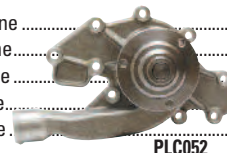

Hylomar Gasket Sealer Official sealer used by Land Rover during assembly.



Supplied in 3.5 oz. tubesRNA681 \$ 10.95

Sightings

We took a break from shoveling snow off the roof to put together the Sightings for this issue. The number of entries demonstrate that many enthusiasts hunker down while searching out Land Rovers in advertisements, commercials, movies and online sites.

It's always helpful for veteran and novice Sighters alike to review the rules that govern when we award a Coveted Mug:

Rule #1 - All Sightings receive recognition and our appreciation, but not necessarily a mug. We reward only those Sightings that capture the unique qualities of Land Rovers and their owners, and display them in a distinctive way.

Rule #2 - If your Sighting doesn't really surprise you, it won't surprise us, either—thus, we can't award you a mug. We're delighted, but not surprised, that Land Rovers appear in British television programmes, British publications, films with British themes and shows about African safaris. You shouldn't be surprised, either, and should consider looking for other ways to get a coffee mug.

Rule #3 - At an ever-changing date before publication, we close off the Sightings; for this issue it was October 31, 2014. If we've mentioned the Sighting in an earlier issue, we might not mention it again. If you're new to the family of Land Rover enthusiasts, you may not have seen your Sighting in an earlier issue.

Rule #4 - We're not outfitting your kitchen. If you qualify, one mug per Sighting per issue.

Rule #5 - Sightings that are Land Rover references in books go to our Literary Land Rover Editor for mention, but only when space permits.

Rule #6 - Psst... Email submissions—remember, we can't send a mug by email. Send us your real name and shipping address, too. Psst... if we can't read your name and address because of atrocious penmanship, we can't recognize your Sighting, or send you a mug.

Rule #7 - Grudgingly, very grudgingly, the Editor admits he might have made an error. Let us know if you think you've been jobbed, but all decisions of the Editor are final.

Advertisers always love to have Land Rovers fluff up their product. Richard Poole, Madison, MS, found his Series 109" Dormobile used in a Buffalo Herd ad that appeared in a regional magazine. J.D. Gamling, Mobile, AL, spotted a clever "Prep My Ride" t-shirt for sale in the Lauren James catalogue, complete with a pink Defender 90. Lawrence Bart, Aspen, CO, Camille Morrison, Savannah, GA, Megan Link, Norfolk, CT, John Geier, Broomfield, CO and John Trotter, Sudbury, MA, noted that the lat-

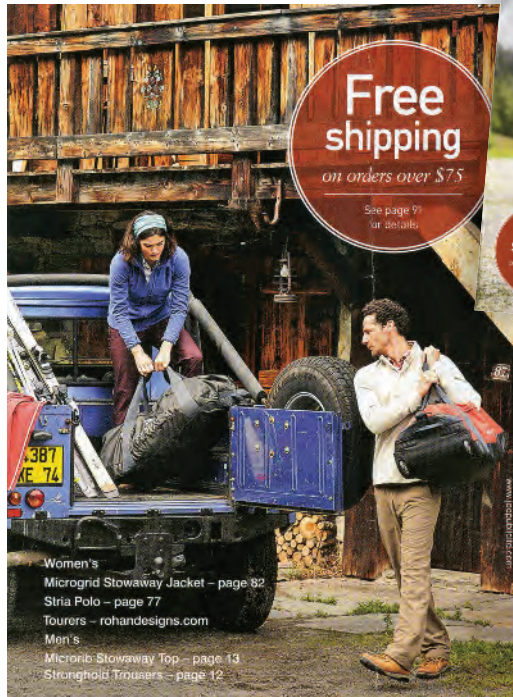

blue Series III in an episode of *Scorpion*. Ryan Ziffer, Lafayette, CO, noted that the *Fast and Loud* guys spent time rescuing a 60s Corvette, but ignored the 109" SW behind it; at least it would have been loud.

Jonathan Speed

March, Roanoke, VA, watched a *Top Gear* episode that matched a Discovery 4 against its 4x4 competitors. He also enjoyed watching a Range Rover Evoque get some screen time on a *CarsTV* episode. Derek Leith, Frontenac, MO and Jay Geaney, Cabot, AR, noted a gun-toting soldier leaping out of a II-A in Africa in a *Black Hat* episode. Speaking of TV, Josh Lombardo [see Rules #2 and #6] and Harvey Allard, Dudley, MA, spotted a Defender on safari on an

Expedia commercial. Bradley Phipps, Medway, MA, noted an ad for OutsideTelevision.com that featured a Series II-A serving as a camera platform.



est Sundance catalogue features a Series I, to draw attention to a lovely model. Sperry Topsiders features a Defender in their online advertising, reported Greg Akin, Abilene, TX. Pendleton Shirts included a red Series Rover in their recent catalogue, reported Ken Gummerston, Baltimore, MD. Kevin Humphrey, Jonesboro, AR, spotted a Defender 90 pulling a stuck Land Cruiser through the mud in the latest Ex-Officio catalogue. Jeff Bang, Staunton, VA, Joshua Lombardo, Cumming, GA, Andy Derousseau, Rogers, AR, Bill Hardaway, Woodland, GA [see Rule #6] and John Porter, Sebastian, FL, spotted a Series Land Rover and four

toffs wearing Dubarry coats in their *Garden and Gun* magazine ad.

Television programs sometimes need the boost of Land Rovers to make them more appealing to viewers. Keith Shepherd, New York, NY, enjoyed seeing a Defender 110 in episodes of *Tyrant*; Gary Hatch, Lancaster, IH, spotted one in *The Mysteries of Laura*. Abel Villesca, Albuquerque, NM, spotted a 110 in an episode of *Madam Secretary* that did not take place in the UK. Kris Heikkila, Mason, NH, stated he's tried for 20 years to find a winning Sighting and succeeded with the



Steve Andrews, Easton, MD, spotted a Series Rover at work in an article in *Modern Farmer*. Jonathan Speed March, Roanoke, VA, found Range Rovers and Defenders in an anime series called *Tokyo ESP*. Nelson Rochester, San Antonio, TX, sent in a terrific photo from 1968, of the royal couple with their Series Land Rover [see Rule #2]. "Surf's up," noted Mark Sterrett, Watsonville, CA, as a Defender brought boards to a surfing locale in *Surfer Magazine*. Eric Wolff, Newport News, VA, spotted a Series 109" at EuroDisney, outside

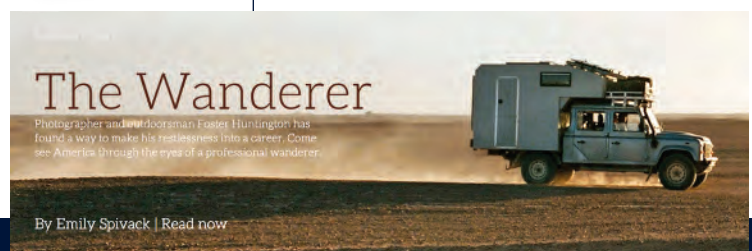

of Paris. Adrian Haskaj, Fayetteville, NC, purchased a copy of *African Critters* at a children's book fair and enjoyed seeing the military Land Rovers on its pages. Charles Bell, Mobile, AL, enjoyed finding the Series III in his kid's book, *Thea Stilton and the Journey to the Lions Den*. Kenis Sweet, Queensbury, NY and Marc Waiter, Osage, IA, found Defenders on safari in an article in AAA magazine.

Tom Slaughter, Maywood, NJ, started a thread on the Defender Source forum on Rovers North Sightings mugs. Ryan Cope, Orem, UT, noted that Emily Spivak's photo book, *The Wanderer*, came up on Ebay's home page; the photo chosen was a Defender 130 camper conversion. Mac Surber, Westborough, MA, spotted a Defender 90 in a special offered on the SteepAndCheap app/website. We usually don't receive political satire Sightings, but Patrick McGrew, Albuquerque, NM, enjoyed a Palestinian spoof of ISIS; how nice to see a Land Rover in a newspaper cartoon. Alden Streatly, Lake Oswego, OR, noted one in "Gazelles" in an issue of *The Oregonian*. The Vermont-based band Phish used a Series Land Rover in their promotional posters for a Labor Day festival in Colorado, reported Bill Schimikowski, Westboro, MA.

These companies have used Land Rovers in sequential catalogues and/or online, but we want to give credit to Sighters for reporting them to us. Boden USA returns



with a Series III in their Fall catalogue, noted John Kwasnik, Sherburne, NY, Tammy Lassiter, Centerville, VA, Saskia Lynn Comess, Bellingham, WA, Dave Moran, Newtown, PA, Dave Smith, Scottsdale, AZ, Derek Leath, Frontenac, MO and Andy Derousseau, Rogers, AR. Curt Kolcun, Leesburg, VA, Mike Stenzler,

Wilton, CT, Camille Morrison, Savannah, GA, Gus Davion, Short Hills, NJ and Bob Rubery, North Tustin, CA, spotted a late Series II-A in the Field Outfitters catalogue. Gus Davino, Short Hills, NJ, spotted a "109" in the Bloomingdale's catalogue. Eddie Bauer continues its use of Land Rovers in a recent catalogue, noted Dave Morrison, Rockaway, NJ. Warwick Hansell, Salt Lake City, UT, and Spencer Norcross, Arlington, VA, reminded us of the Land Rovers in the Orvis catalogue. Woolrich continues its use of Land Rover imagery on their website, reported Jim Ksionzyk [See Rule #6]. Frank Twarog, Hinesburg, VT, spotted the Rover again in the Rohan catalogue.



We've mentioned these in previous issues, but we want to give a shout out to Paul Kennington, La Grande, OR, for spotting the Defender 110 in the Hewlett Packard tablet ad. Ken Gummerson, Baltimore, MD, reminded us of the Land Rover appearances in the Sundance catalogue. Ron Dade, Washington, DC and, Savannah, GA, reminded us of the Land Rover in the Kevins catalogue. //

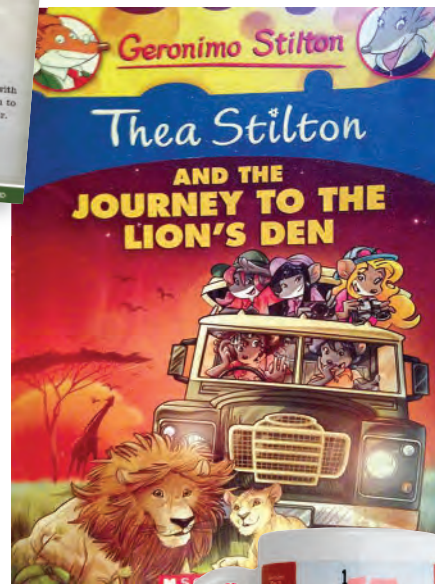

Winners:

Bradley Phipps
Medway, MA

Andrew Derousseau
Rogers, AR

Abel Villesca
Albuquerque, NM

Gary Hatch
Lancaster, OH

John Geier
Broomfield, CO

Joshua Lombardo
Cumming, GA

Mac Surber
Westborough, MA

Kris Heikkila
Mason, NH

John Porter
Sebastian, FL

Ken Gummerson
Baltimore, MD

Dr. Jeff Bang
Staunton, VA

Bill Schimikowski
Westboro, MA

Kevin Humphrey
Jonesboro, AR

Mark Sterrett
Watsonville, CA

Meg Link
Norfolk, CT

Camille Morrison
Savannah, GA

John Trotter
Sudbury, MA

Greg Akin
Abilene, TX

Keith Shepherd
New York, NY

Lawrence Bart
Aspen, CO

Steve Andrews
Easton, MD

James Gramling
Mobile, AL

Richard Poole
Madison, MS



MANTEC

Raised Air Intakes



Raised Air Intakes

Series IIA, III, Defender 90/110 NA, Round Metal Tubed.....	RNA2002	\$ 369.00
Defender NAS Round Metal Tubed	RNA1002	\$ 489.00
Defender 200Tdi, Round Metal Tubed.....	RNA1102	\$ 379.00
Defender 300 Tdi, Td5, Round ABS Tubed.....	RNA2002TDI	\$ 369.00
Defender 300 Tdi, Td5, Flexlit ABS Angular	RNA2013	\$ 309.00
Discovery I, Round Metal Tubed	RNA1003	\$ 399.00
Discovery II, Round Metal Tubed	RNA1013	\$ 498.00
Range Rover Classic, Round Metal Tubed.....	RNA1115	\$ 398.95
LR3, Flexlit ABS Angular	RNI473	\$ 799.95



Hi-Lift



Synthetic Fiber Winch Line

Superior to 3/8" steel winch cable, this 12-strand synthetic Dynalene winch line by Marlow is 70% stronger and 8 times lighter than steel. Fitted with drum fixing point and spliced tubular thimble. 9mm x 125', Graphite color. **RNR2021 \$ 329.00**



Jack Adapter

For use with Hi-Lift Jacks only. Fits into receptacles located on Defender chassis, rock sliders & winch bumpers offered by Rovers North. **PLA908HL \$ 68.50**



Hi-Lift Jack Cover

Black Neoprene. **NJC \$ 24.00**



Kinetic Recovery Rope

Significantly amplifies the recovery power of your Land Rover. Far superior to recovery straps without the associated shock. **Requires securely fastened recovery hitches for safe use.** Kinetic Rope 24mm diameter x 8m, 12,030kg (26,500lb) military rating. **KRR001 \$ 109.90**

Lift-Mate

Lift directly from the wheel **LM100 \$ 37.95**



Hi-Lift Off-Road Kit

The perfect for off-road enthusiasts.

Includes:

- Winch Tensioner
 - Custom Nose Attachment
 - 8ft. Tree Saver Strap
 - Pair/Hi-Lift Gloves
 - Gear Bag
- ORK \$ 59.00**



Hi-Lift All Cast Jacks

Hi-Lift XTREME



48 inch
HL485
\$ 74.00

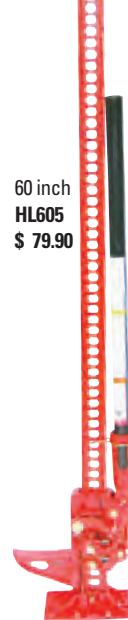

60 inch
HL605
\$ 79.90

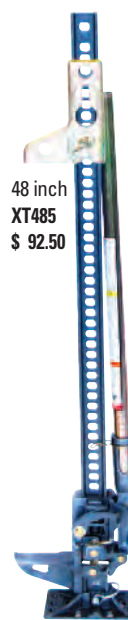

48 inch
XT485
\$ 92.50



60 inch
XT605
\$ 96.50

Rear Access Ladders

LR3 and LR4, Genuine
RNQ613 \$ 429.95

Discovery I, II, Genuine
RNA661 \$ 159.95

Discovery I, II, ProLine
PLA661 \$ 99.98

Defender, Safety Devices
G4 Expedition

RRL2046SSS \$ 329.95

Defender, Safety Devices

Explorer

RRL2336SSS \$ 398.95



Hi-Lift Jack Base

Use for soft ground. **ORB \$ 36.90**



ROVERS

MAGAZINE

© 2015 Rovers North, Inc
1319 VT Route 128
Westford, Vermont 05494-9601, USA
Sales and Tech Support: 802.879.0032
roversnorth.com

PRSR Std
US Postage
Paid
Permit 19
Burl., VT
05401

LAND ROVER GENUINE PARTS.
TRUE QUALITY COMES FROM WITHIN.



ABOVE AND BEYOND



ROVERS NORTH INC. 1319 VT Route 128, Westford, Vermont 05494 USA
Phone 1 802 879-0032 www.roversnorth.com Fax 1 802 879-9152
Family owned by enthusiasts since 1979.